

KEITHLEY

Model 2302/2302-PJ/2306/2306-PJ

Battery/Charger Simulator

Instruction Manual

A GREATER MEASURE OF CONFIDENCE

WARRANTY

Keithley Instruments, Inc. warrants this product to be free from defects in material and workmanship for a period of 1 year from date of shipment.

Keithley Instruments, Inc. warrants the following items for 90 days from the date of shipment: probes, cables, rechargeable batteries, diskettes, and documentation.

During the warranty period, we will, at our option, either repair or replace any product that proves to be defective.

To exercise this warranty, write or call your local Keithley representative, or contact Keithley headquarters in Cleveland, Ohio. You will be given prompt assistance and return instructions. Send the product, transportation prepaid, to the indicated service facility. Repairs will be made and the product returned, transportation prepaid. Repaired or replaced products are warranted for the balance of the original warranty period, or at least 90 days.

LIMITATION OF WARRANTY

This warranty does not apply to defects resulting from product modification without Keithley's express written consent, or misuse of any product or part. This warranty also does not apply to fuses, software, non-rechargeable batteries, damage from battery leakage, or problems arising from normal wear or failure to follow instructions.

THIS WARRANTY IS IN LIEU OF ALL OTHER WARRANTIES, EXPRESSED OR IMPLIED, INCLUDING ANY IMPLIED WARRANTY OF MERCHANTABILITY OR FITNESS FOR A PARTICULAR USE. THE REMEDIES PROVIDED HEREIN ARE BUYER'S SOLE AND EXCLUSIVE REMEDIES.

NEITHER KEITHLEY INSTRUMENTS, INC. NOR ANY OF ITS EMPLOYEES SHALL BE LIABLE FOR ANY DIRECT, INDIRECT, SPECIAL, INCIDENTAL OR CONSEQUENTIAL DAMAGES ARISING OUT OF THE USE OF ITS INSTRUMENTS AND SOFTWARE EVEN IF KEITHLEY INSTRUMENTS, INC., HAS BEEN ADVISED IN ADVANCE OF THE POSSIBILITY OF SUCH DAMAGES. SUCH EXCLUDED DAMAGES SHALL INCLUDE, BUT ARE NOT LIMITED TO: COSTS OF REMOVAL AND INSTALLATION, LOSSES SUSTAINED AS THE RESULT OF INJURY TO ANY PERSON, OR DAMAGE TO PROPERTY.



Keithley Instruments, Inc. • 28775 Aurora Road • Cleveland, OH 44139 • 440-248-0400 • Fax: 440-248-6168 • <http://www.keithley.com>

BELGIUM:

Keithley Instruments B.V.

Bergensesteenweg 709 • B-1600 Sint-Pieters-Leeuw • 02/363 00 40 • Fax: 02/363 00 64

CHINA:

Keithley Instruments China

Yuan Chen Xin Building, Room 705 • 12 Yumin Road, Dewai, Madian • Beijing 100029 • 8610-62022886 • Fax: 8610-62022892

FRANCE:

Keithley Instruments Sarl

3, allée des Garays • 91127 Palaiseau Cedex • 01-64 53 20 20 • Fax: 01-60 11 77 26

GERMANY:

Keithley Instruments GmbH

Landsberger Strasse 65 • 82110 Germering • 089/84 93 07-40 • Fax: 089/84 93 07-34

GREAT BRITAIN:

Keithley Instruments Ltd

The Minster • 58 Portman Road • Reading, Berkshire RG30 1EA • 0118-9 57 56 66 • Fax: 0118-9 59 64 69

INDIA:

Keithley Instruments GmbH

Flat 2B, WILOCRISSA • 14, Rest House Crescent • Bangalore 560 001 • 91-80-509-1320/21 • Fax: 91-80-509-1322

ITALY:

Keithley Instruments s.r.l.

Viale S. Gimignano, 38 • 20146 Milano • 02-48 39 16 01 • Fax: 02-48 30 22 74

NETHERLANDS:

Keithley Instruments B.V.

Postbus 559 • 4200 AN Gorinchem • 0183-635333 • Fax: 0183-630821

SWITZERLAND:

Keithley Instruments SA

Kriesbachstrasse 4 • 8600 Dübendorf • 01-821 94 44 • Fax: 01-820 30 81

TAIWAN:

Keithley Instruments Taiwan

1 Fl. 85 Po Ai Street • Hsinchu, Taiwan, R.O.C. • 886-3572-9077 • Fax: 886-3572-903

Model 2302/2302-PJ/2306/2306-PJ
Battery/Charger Simulator
Instruction Manual

©1999, Keithley Instruments, Inc.
All rights reserved.
Cleveland, Ohio, U.S.A.
Third Printing, February 2001
Document Number: 2306-901-01 Rev. C

Manual Print History

The print history shown below lists the printing dates of all Revisions and Addenda created for this manual. The Revision Level letter increases alphabetically as the manual undergoes subsequent updates. Addenda, which are released between Revisions, contain important change information that the user should incorporate immediately into the manual. Addenda are numbered sequentially. When a new Revision is created, all Addenda associated with the previous Revision of the manual are incorporated into the new Revision of the manual. Each new Revision includes a revised copy of this print history page.

Revision A (Document Number 2306-901-01)	March 1999
Addendum A (Document Number 2306-901-02).....	January 2000
Revision B (Document Number 2306-901-01)	May 2000
Addendum B (Document Number 2306-901-02).....	November 2000
Revision C (Document Number 2306-901-01)	February 2001

Safety Precautions

The following safety precautions should be observed before using this product and any associated instrumentation. Although some instruments and accessories would normally be used with non-hazardous voltages, there are situations where hazardous conditions may be present.

This product is intended for use by qualified personnel who recognize shock hazards and are familiar with the safety precautions required to avoid possible injury. Read the operating information carefully before using the product.

The types of product users are:

Responsible body is the individual or group responsible for the use and maintenance of equipment, for ensuring that the equipment is operated within its specifications and operating limits, and for ensuring that operators are adequately trained.

Operators use the product for its intended function. They must be trained in electrical safety procedures and proper use of the instrument. They must be protected from electric shock and contact with hazardous live circuits.

Maintenance personnel perform routine procedures on the product to keep it operating, for example, setting the line voltage or replacing consumable materials. Maintenance procedures are described in the manual. The procedures explicitly state if the operator may perform them. Otherwise, they should be performed only by service personnel.

Service personnel are trained to work on live circuits, and perform safe installations and repairs of products. Only properly trained service personnel may perform installation and service procedures.

Keithley products are designed for use with electrical signals that are rated Installation Category I and Installation Category II, as described in the International Electrotechnical Commission (IEC) Standard IEC 60664. Most measurement, control, and data I/O signals are Installation Category I and must not be directly connected to mains voltage or to voltage sources with high transient over-voltages. Installation Category II connections require protection for high transient over-voltages often associated with local AC mains connections. The user should assume all measurement, control, and data I/O connections are for connection to Category I sources unless otherwise marked or described in the Manual.

Exercise extreme caution when a shock hazard is present. Lethal voltage may be present on cable connector jacks or test fixtures. The American National Standards Institute (ANSI) states that a shock hazard exists when voltage levels greater than 30V RMS, 42.4V peak, or 60VDC are present. **A good safety practice is to expect that hazardous voltage is present in any unknown circuit before measuring.**

Users of this product must be protected from electric shock at all times. The responsible body must ensure that users are prevented access and/or insulated from every connection point. In some cases, connections must be exposed to potential human contact. Product users in these circumstances must be trained to protect themselves from the risk of electric shock. If the circuit is capable of operating at or above 1000 volts, **no conductive part of the circuit may be exposed.**

Do not connect switching cards directly to unlimited power circuits. They are intended to be used with impedance limited sources. NEVER connect switching cards directly to AC mains. When connecting sources to switching cards, install protective devices to limit fault current and voltage to the card.

Before operating an instrument, make sure the line cord is connected to a properly grounded power receptacle. Inspect the connecting cables, test leads, and jumpers for possible wear, cracks, or breaks before each use.

When installing equipment where access to the main power cord is restricted, such as rack mounting, a separate main input power disconnect device must be provided, in close proximity to the equipment and within easy reach of the operator.

For maximum safety, do not touch the product, test cables, or any other instruments while power is applied to the circuit under test. ALWAYS remove power from the entire test system and discharge any capacitors before: connecting or disconnecting cables or jumpers, installing or removing switching cards, or making internal changes, such as installing or removing jumpers.

Do not touch any object that could provide a current path to the common side of the circuit under test or power line (earth) ground. Always make measurements with dry hands while standing on a dry, insulated surface capable of withstanding the voltage being measured.

The instrument and accessories must be used in accordance with its specifications and operating instructions or the safety of the equipment may be impaired.

Do not exceed the maximum signal levels of the instruments and accessories, as defined in the specifications and operating information, and as shown on the instrument or test fixture panels, or switching card.

When fuses are used in a product, replace with same type and rating for continued protection against fire hazard.

Chassis connections must only be used as shield connections for measuring circuits, NOT as safety earth ground connections.

If you are using a test fixture, keep the lid closed while power is applied to the device under test. Safe operation requires the use of a lid interlock.

If a  screw is present, connect it to safety earth ground using the wire recommended in the user documentation.

The  symbol on an instrument indicates that the user should refer to the operating instructions located in the manual.

The  symbol on an instrument shows that it can source or measure 1000 volts or more, including the combined effect of normal and common mode voltages. Use standard safety precautions to avoid personal contact with these voltages.

The **WARNING** heading in a manual explains dangers that might result in personal injury or death. Always read the associated information very carefully before performing the indicated procedure.

The **CAUTION** heading in a manual explains hazards that could damage the instrument. Such damage may invalidate the warranty.

Instrumentation and accessories shall not be connected to humans.

Before performing any maintenance, disconnect the line cord and all test cables.

To maintain protection from electric shock and fire, replacement components in mains circuits, including the power transformer, test leads, and input jacks, must be purchased from Keithley Instruments. Standard fuses, with applicable national safety approvals, may be used if the rating and type are the same. Other components that are not safety related may be purchased from other suppliers as long as they are equivalent to the original component. (Note that selected parts should be purchased only through Keithley Instruments to maintain accuracy and functionality of the product.) If you are unsure about the applicability of a replacement component, call a Keithley Instruments office for information.

To clean an instrument, use a damp cloth or mild, water based cleaner. Clean the exterior of the instrument only. Do not apply cleaner directly to the instrument or allow liquids to enter or spill on the instrument. Products that consist of a circuit board with no case or chassis (e.g., data acquisition board for installation into a computer) should never require cleaning if handled according to instructions. If the board becomes contaminated and operation is affected, the board should be returned to the factory for proper cleaning/servicing.

Table of Contents

1	Getting Started	
	General information	1-2
	Warranty information	1-2
	Contact information	1-2
	Safety symbols and terms	1-2
	Specifications	1-2
	Inspection	1-3
	Options and accessories	1-3
	Power supply overview	1-4
	Remote display option	1-6
	Power-up	1-7
	Line power connection	1-7
	Power-up sequence	1-7
	Fuse replacement	1-8
	Display modes	1-9
	Default settings	1-10
	Setups — Save, Power-on, and Recall	1-12
	Menu	1-12
	Getting around the MENU	1-15
	SCPI programming	1-16
2	Basic Power Supply Operation	
	Test connections	2-2
	Remote sense	2-3
	Local sense	2-4
	Outputting voltage and current	2-5
	Setting voltage protection value	2-5
	Selecting proper current range	2-6
	Selecting current limit mode	2-6
	Editing output voltage and current limit values	2-7
	Pressing operate	2-9
	Output bandwidth	2-9
	Output impedance	2-11
	Changing the battery channel's output impedance	2-11
	SCPI programming — outputting voltage and current	2-12
	Command notes (outputting voltage and current)	2-13
	Reading back V and I	2-14
	Actual V and I display mode	2-14
	Measurement configuration	2-15
	SCPI programming — measure V and I, and DVM input	2-16
	Command notes (measure V and I, and DVM input)	2-17

Independent voltage measurements (DVM)	2-17
DVM input display mode	2-17
Measurement configuration	2-18
SCPI programming — DVM	2-18
Sink operation	2-18
Programming examples	2-20
Outputting and reading back V and I	2-20
DVM measurements	2-21

3 **Pulse Current Measurements**

Overview	3-2
Trigger level	3-3
Trigger level range	3-3
Trigger delay	3-4
Integration times	3-5
Average readings count	3-5
Measurement configuration	3-6
Current range	3-6
Integration times	3-7
Average readings count	3-7
Trigger delay, trigger level range, and trigger level	3-7
Pulse current display mode	3-9
Pulse current measurement procedure	3-10
Determining correct trigger level (pulse current)	3-10
SCPI programming — pulse current measurements	3-13
Command notes (pulse current measurements)	3-16
Using FAST, SEARCh, and DETect	3-17
Pulse current digitization	3-21
Pulse current step method	3-22
TLEV steps	3-22
Timeout setting	3-27
Integration time	3-28
Trigger level range	3-28
Programming examples	3-28
Pulse current measurements	3-29
Pulse current digitization	3-30
Pulse current STEP method (battery channel only)	3-31

4	Long Integration Measurements	
	Overview	4-2
	Integration time	4-3
	Trigger edge	4-3
	Trigger level	4-4
	Trigger level range	4-4
	Pulse timeout.....	4-4
	Measurement configuration.....	4-6
	Current range	4-6
	Integration time	4-6
	Pulse timeout.....	4-7
	Trigger edge, trigger level, and trigger level range	4-7
	Long integration display mode	4-9
	Long integration measurement procedure.....	4-9
	General notes	4-10
	Determining correct trigger level (long integration).....	4-10
	SCPI programming	4-12
	Command notes (long integration measurements)	4-14
	Using FAST, SEARCh, and DETect.....	4-14
	Programming examples.....	4-18
5	Relay Control	
	Overview	5-2
	Connections	5-4
	Controlling relays	5-4
	SCPI programming	5-5
6	GPIB Operation	
	Introduction	6-2
	GPIB bus connections	6-2
	Primary address	6-4
	Setting the GPIB timeout for responses	6-4
	Long integration readings	6-5
	Pulse current readings	6-5
	MAV (Message Available Bit)	6-5
	General bus commands	6-6
	REN (remote enable)	6-6
	IFC (interface clear)	6-6
	LLO (local lockout)	6-7
	GTL (go to local)	6-7
	DCL (device clear)	6-7
	SDC (selective device clear)	6-7
	GET (group execute trigger)	6-7
	SPE, SPD (serial polling)	6-7

Front panel aspects of GPIB operation	6-8
Remote indicator and LOCAL key	6-8
Error and status messages	6-8
Programming syntax	6-9
Command words	6-9
Program messages	6-12
Response messages	6-14
Message exchange protocol	6-14

7 **Status Structure**

Overview	7-2
Status byte and SRQ	7-2
Status register sets	7-2
Queues	7-2
Clearing registers and queues	7-4
Programming and reading registers	7-5
Programming enable registers	7-5
Reading registers	7-5
Status byte and service request (SRQ)	7-6
Status byte register	7-7
Service request enable register	7-7
Serial polling and SRQ	7-8
Status byte and service request commands	7-9
Status register sets	7-10
Register bit descriptions	7-10
Condition registers	7-17
Event registers	7-17
Event enable registers	7-18
Programming example — program and read measurement event register	7-19
Queues	7-19
Output queue	7-20
Error queue	7-20
Programming example — read error queue	7-21

8 **Common Commands**

Overview	8-2
Command notes (IEEE-488.2 common commands and queries)	8-3

9 **Signal Oriented Measurement Commands**

Overview	9-2
Command notes (Signal oriented measurement commands and queries)	9-3

10	DISPlay, FORMat, and SYSTem	
	DISPlay subsystem	10-2
	Command notes (SCPI commands — display)	10-2
	FORMat subsystem	10-4
	Command notes (SCPI commands — data format)	10-5
	:SYSTem subsystem	10-7
	Command notes (SCPI commands — system)	10-8
11	SCPI Tables	
	SCPI command subsystems reference tables	11-2
12	Performance Verification	
	Introduction	12-2
	Verification test requirements	12-2
	Environmental conditions	12-2
	Warm-up period	12-2
	Line power	12-3
	Recommended test equipment	12-3
	Resistor connections	12-3
	Resistor considerations	12-4
	Verification limits	12-4
	Example limits calculation	12-4
	Performing the verification test procedures	12-4
	Test summary	12-4
	Test considerations	12-5
	Output voltage accuracy	12-5
	Voltage readback accuracy	12-6
	Compliance current accuracy	12-7
	Current readback accuracy	12-8
	5A range readback accuracy	12-8
	5mA range readback accuracy	12-9
	500mA range readback accuracy	12-11
	Digital voltmeter input accuracy	12-12
13	Calibration	
	Introduction	13-2
	Environmental conditions	13-2
	Temperature and relative humidity	13-2
	Warm-up period	13-2
	Line power	13-2
	Calibration considerations	13-2
	Calibration cycle	13-3
	Recommended calibration equipment	13-3

Resistor connections	13-3
Resistor considerations	13-3
Front panel calibration	13-4
Remote calibration	13-11
Remote calibration display	13-11
Remote calibration procedure	13-11
Changing the calibration code	13-17
Changing the code from the front panel	13-17
Changing the code by remote	13-18
Resetting the calibration code	13-18
Viewing calibration date and count	13-19
Viewing date and count from the front panel	13-19
Acquiring date and count by remote	13-19

14 Disassembly

Introduction	14-2
Handling and cleaning	14-2
Handling PC boards	14-2
Solder repairs	14-2
Static sensitive devices	14-2
Assembly drawings	14-3
Disassembly procedures	14-3
Case cover removal	14-3
Analog board removal	14-4
Digital board removal	14-4
Front panel disassembly	14-4
Removing mechanical components	14-5
Instrument reassembly	14-5

15 Replaceable Parts

Introduction	15-2
Ordering information	15-2
Factory service	15-2
Parts lists and component layouts	15-2

A Specifications

B Error and Status Messages

C	Calibration Reference	
	Introduction	C-2
	Command summary	C-2
	Miscellaneous commands	C-2
	Detecting calibration errors	C-6
	Reading the error queue	C-6
	Error summary	C-6
	Status byte EAV (Error Available) bit	C-6
	Generating an SRQ on error	C-6
	Detecting calibration step completion	C-8
	Using the *OPC command	C-8
	Using the *OPC? query	C-8
	Generating an SRQ on calibration complete	C-8
D	Calibration Program	
	Introduction	D-2
	Computer hardware requirements	D-2
	Software requirements	D-2
	Calibration equipment	D-2
	General program instructions	D-3
	Program D-1	D-3
E	Applications Guide	
	Simulating battery impedance	E-2
	Variable output impedance control on channel #1	E-2
F	Model 2302 Specifics	
	General information	F-2
	Specifications	F-2
	Power supply overview	F-2
	Operational differences	F-2
	Front panel operation	F-2
	SCPI operation	F-2
	Calibration	F-2

List of Illustrations

1	Getting Started	
Figure 1-1	Model 2306 dual channel battery/charger simulator	1-4
Figure 1-2	Simplified power supply diagram	1-5
Figure 1-3	Remote display option	1-6
Figure 1-4	Fuse drawer location	1-8
2	Basic Power Supply Operation	
Figure 2-1	Four-wire sense connections for battery and charger channels	2-3
Figure 2-2	Local sense connections	2-4
Figure 2-3	Sink operation	2-19
Figure 2-4	Preferred method	2-19
3	Pulse Current Measurements	
Figure 3-1	Pulse current measurement	3-2
Figure 3-2	Trigger delay for high pulse current measurement	3-4
Figure 3-3	Determining voltage and current characteristics	3-11
Figure 3-4	PCURent and SEARCh time for pulse high measurement ...	3-18
Figure 3-5	Sample pulse forms for step method	3-24
Figure 3-6	Sample one-shot only pulses for step method	3-24
Figure 3-7	Sample :STEP Pulse measurement	3-25
Figure 3-8	Pulse form with rise and fall steps	3-25
Figure 3-9	Pulse form with down steps first (600µsec step duration) ...	3-26
4	Long Integration Measurements	
Figure 4-1	Steady state for waveforms based on low pulse times	4-3
Figure 4-2	Long integration, search, and reading time comparison	4-5
Figure 4-3	TOUT and search time	4-15
5	Relay Control	
Figure 5-1	External source relay control	5-3
Figure 5-2	Internal source relay control	5-3
Figure 5-3	Relay connector (9-pin D-sub)	5-4
6	GPIB Operation	
Figure 6-1	IEEE-488 connector	6-2
Figure 6-2	Daisy chaining	6-3

7	Status Structure	
Figure 7-1	Status model structure	7-3
Figure 7-2	16-bit status register	7-5
Figure 7-3	Status byte and service request	7-6
Figure 7-4	Standard event status	7-11
Figure 7-5	Operation event status	7-13
Figure 7-6	Measurement event status	7-15
Figure 7-7	Questionable event status	7-16

10	DISPlay, FORMat, and SYStem	
Figure 10-1	IEEE-754 single precision data format	10-5
Figure 10-2	IEEE-754 double precision data format	10-6

12	Performance Verification	
Figure 12-1	Connections for voltage verification tests	12-5
Figure 12-2	Connections for output current and 5A range current verification tests	12-7
Figure 12-3	Connections for 5mA current verification tests	12-10
Figure 12-4	Connections for 500mA current verification tests	12-11
Figure 12-5	Connections for DVM accuracy verification	12-13

13	Calibration	
Figure 13-1	Connections for voltage calibration	13-5
Figure 13-2	Connections for 5A/500mA current calibration	13-7
Figure 13-3	Connections for 5mA range calibration	13-8
Figure 13-4	Jumper connections to reset calibration code	13-19

E	Application Guide	
Figure E-1	Battery schematic	E-2
Figure E-2	Actual battery pack terminal voltage during GSM phone simulation	E-3
Figure E-3	Simulated GSM phone current profile	E-4
Figure E-4	Electronic resistance of NiCd, NiMH, and Li ion battery packs	E-4
Figure E-5	Effect of the variable output impedance control	E-5
Figure E-6	Li ion voltage drop during the transmit portion of the pulse	E-6
Figure E-7	Model 2306 voltage drop during the transmit portion of the pulse	E-7

F	Model 2302 Specifics	
Figure F-1	Model 2302 and 2302-PJ single channel battery simulator ..	F-3

List of Tables

1	Getting Started	
Table 1-1	Display samples	1-10
Table 1-2	Factory defaults (RST)	1-11
Table 1-3	Main MENU structure (accessed by pressing the MENU key on the Front Panel)	1-13
2	Basic Power Supply Operation	
Table 2-1	Current ranges	2-6
Table 2-2	Output bandwidth setting for a channel	2-10
Table 2-3	SCPI command summary — outputting voltage and current	2-12
Table 2-4	SCPI commands — measure V and I, and DVM input	2-16
3	Pulse Current Measurements	
Table 3-1	TRIG NOT DETECTED message	3-12
Table 3-2	SCPI commands — pulse current measurements	3-13
Table 3-3	PCURrent FAST, SEARch, and DETect commands	3-19
Table 3-4	Setting UP and DOWN commands	3-23
Table 3-5	Sample TLEV values for Figure 3-8	3-26
Table 3-6	Sample integration times	3-28
4	Long Integration Measurements	
Table 4-1	TRIG NOT DETECTED message	4-11
Table 4-2	SCPI commands — long integration measurements	4-12
Table 4-3	FAST, SEARch, and DETect command reference	4-15
5	Relay Control	
Table 5-1	Relay pinouts (for Figure 5-3)	5-4
Table 5-2	SCPI command — output relay control	5-5
6	GPIB Operation	
Table 6-1	General bus commands	6-6

7

Status Structure

Table 7-1	Common and SCPI commands — reset registers and clear queues	7-4
Table 7-2	Command commands — status byte and service request enable registers	7-9
Table 7-3	Common and SCPI commands — condition registers	7-17
Table 7-4	Common and SCPI commands — event registers	7-17
Table 7-5	Common and SCPI commands — event enable registers	7-18
Table 7-6	SCPI commands — error queue	7-21

8

Common Commands

Table 8-1	IEEE-488.2 common commands and queries (refer to Section 7)	8-2
Table 8-2	*OPC and *OPC? commands	8-4

9

Signal Oriented Measurement Commands

Table 9-1	Signal oriented measurement command summary	9-2
-----------	---	-----

10

DISPlay, FORMat, and SYSTem

Table 10-1	SCPI commands — display	10-2
Table 10-2	SCPI commands — data format	10-4
Table 10-3	SCPI commands — system	10-7

11

SCPI Tables

Table 11-1	Display command summary (refer to Display subsystem in Section 10)	11-3
Table 11-2	FORMat command summary (refer to Format subsystem in Section 10)	11-3
Table 11-3	OUTPut command summary (refer to Tables 2-3 and 5-2) ..	11-4
Table 11-4	SENSE command summary (refer to Tables 2-3, 3-2, and 4-2)	11-5
Table 11-5	SOURce command summary (refer to Table 2-3)	11-14
Table 11-6	STATus command summary (refer to Section 7)	11-15
Table 11-7	SYSTem command summary (refer to System subsystem in Section 10)	11-17
Table 11-8	Signal oriented measurement command summary (refer to Section 9)	11-17

12

Performance Verification

Table 12-1	Recommended verification equipment	12-3
Table 12-2	Output voltage accuracy limits	12-6
Table 12-3	Voltage readback accuracy limits	12-7
Table 12-4	Compliance current accuracy limits	12-8

Table 12-5	5A range current readback accuracy limits	12-9
Table 12-6	5mA range current readback accuracy limits	12-11
Table 12-7	500mA range current readback accuracy limits	12-12
Table 12-8	Digital voltmeter input accuracy limits	12-14

13 Calibration

Table 13-1	Recommended calibration equipment	13-3
Table 13-2	Model 2306 front panel calibration summary	13-9
Table 13-3	Remote calibration summary	13-16

15 Replaceable Parts

Table 15-1	Digital board parts list	15-3
Table 15-2	Analog board parts list	15-7
Table 15-3	Display board parts list	15-14
Table 15-4	Mechanical parts list	15-15

B Error and Status Messages

Table B-1	Error and status messages	B-2
-----------	---------------------------------	-----

C Calibration Reference

Table C-1	Remote calibration command summary	C-3
Table C-2	Calibration errors	C-7

1 Getting Started

- **General information** — Provides general information including warranty information, contact information, safety symbols and terms, inspection and available options and accessories.
- **Power supply overview** — Summarizes the capabilities of the power supply.
- **Remote display option** — Explains how to use the optional Model 2304-DISP Display Module.
- **Power-up** — Covers line power connection, the power up sequence, and fuse replacement.
- **Display modes** — Explains the four display modes of the power supply.
- **Default settings** — Lists the factory default settings, and explains how to save and recall settings.
- **Menu** — Provides a table that summarizes the menu items and includes rules to navigate the menu structure.
- **SCPI programming** — Explains how SCPI commands are presented in this manual.

NOTES *This manual covers Keithley Models 2302, 2302-PJ, 2306, and 2306-PJ simulators (power supplies). Since the Model 2302 and 2302-PJ are single channel battery simulators, functions related to the second channel (i.e., the charger channel) are not available for the Model 2302 and 2302-PJ. Therefore:*

- *battery and charger channel features contained in this manual apply for the Model 2306 and 2306-PJ*
- *only battery channel features contained in this manual apply for the Model 2302 and 2302-PJ*

Refer to Appendix F for specific Model 2302 and 2302-PJ information.

Information contained in this section applies to all power supply channels (unless otherwise noted). In this manual, channel 1 refers to the battery channel while channel 2 refers to the charger channel (2306 and 2306-PJ feature only).

General information

Warranty information

Warranty information is located at the front of this manual. Should your power supply require warranty service, contact the Keithley representative or authorized repair facility in your area for further information. When returning the instrument for repair, be sure to fill out and include the service form at the back of this manual to provide the repair facility with the necessary information.

Contact information

If you have any questions after reviewing this information, please contact your local Keithley representative or call one of our Applications Engineers at 1-800-348-3735 (U.S. and Canada only). Worldwide phone numbers are listed at the front of this manual.

Safety symbols and terms

Keithley uses a standard set of safety symbols and terms that may be found on an instrument or in its manual.

The  symbol on an instrument indicates that the user should refer to the operating instructions located in the manual.

The  symbol on an instrument shows that high voltage may be present on the terminal(s). Use standard safety precautions to avoid personal contact with these voltages.

The **WARNING** heading used in a manual explains dangers that might result in personal injury or death. Always read the associated information very carefully before performing the indicated procedure.

The **CAUTION** heading used in a manual explains hazards that could damage the instrument. Such damage may invalidate the warranty.

Specifications

Full power supply specifications can be found in Appendix A of this manual.

Inspection

The power supply was carefully inspected electrically and mechanically before shipment. After unpacking all items from the shipping carton, check for any obvious signs of physical damage that may have occurred during transit. (Note: There may be a protective film over the display lens, which can be removed.) Report any damage to the shipping agent immediately. Save the original packing carton for possible future shipment. The following items are included with every order:

- Model 2306 Dual Channel Battery/Charger Simulator with line cord
- Quick Disconnect Output/DVM Input Connector (2)
- Accessories as ordered
- Certificate of calibration
- Model 2302/2306 Instruction Manual (P/N 2306-901-00)
- Model 2302/2306 Quick Results Guide

If an additional manual is required, order the manual package. The manual package includes a manual and any pertinent addenda.

Any improvements or changes concerning the instrument or manual will be explained in an addendum included with the manual. Be sure to note these changes and incorporate them into the manual.

Options and accessories

The following options and accessories are available for the power supply.

- 2304-DISP remote display unit
- Shielded IEEE-488 cable, 1m (3.3 ft) (P/N 7007-1)
- Shielded IEEE-488 cable, 2m (6.6 ft) (P/N 7007-2)
- Single fixed rack mount kit (P/N 4288-1)
- Dual fixed rack mount kit (P/N 4288-2)
- IEEE-488 Interface/controller for the PCI bus (P/N KPCI-488)
- IEEE Interface card for IBM PC/AT (full slot) (P/N KPC-488-2AT)

Power supply overview

The Model 2306 power supply (dual channel battery/charger simulator — see Figure 1-1) can simulate a battery (Channel #1) or a charger (Channel #2).

Figure 1-1
Model 2306 dual channel battery/charger simulator

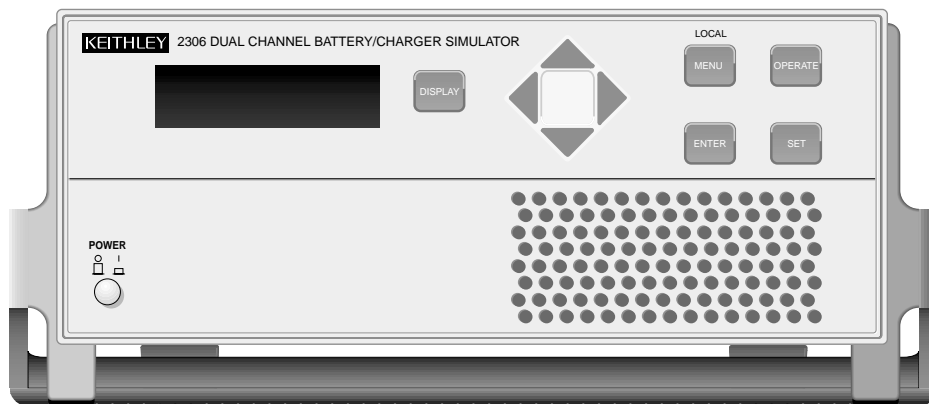

A) Front Panel

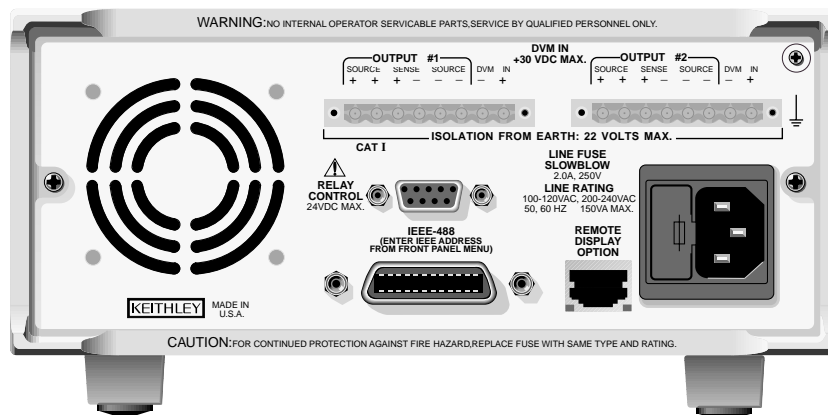

B) Rear Panel

NOTE The output from each channel is isolated from the other channel.

Make sure that the maximum combined channel output is not exceeded (see Specifications in Appendix A). Also, do not exceed 3A when using the power supply as a sink. For output voltages exceeding 5V, the maximum sink current is less than 3A (derate the maximum sink current 0.2A for each volt over 5V).

NOTE When using the power supply as a sink (negative polarity), the power supply is dissipating rather than sourcing power (see “Sink Operation” in Section 2).

A simplified diagram of the power supply is shown in Figure 1-2. Note that it can read back the output voltage (V_{meter}) and current (I_{meter}). Display resolution for voltage readback is 1mV.

Current Readback Range: The Model 2306 has two ranges for current readback: 5A and 5mA. On the 5A range display resolution is 100 μ A, and on the 5mA range resolution is 0.1 μ A.

The power supply also has a digital voltmeter (DVM) that is independent of the power supply circuit. The DVM can measure up to +30V (1mV resolution).

When used with a pulsed load, the power supply can read back peak current, idle current, and average current. See Section 3 for details. A long integration (up to 60 seconds) function is provided to measure average current of a low frequency pulse (long period) or a series of pulses. See Section 4 for details.

Figure 1-2
Simplified power supply diagram

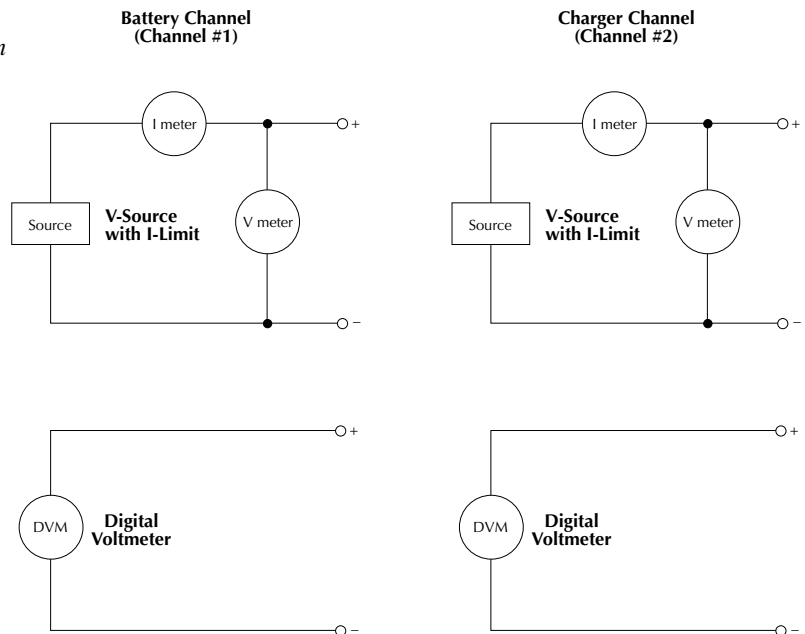

Remote display option

If mounting the power supply in a location where the display cannot be seen or the controls are not easily accessible, use the optional Model 2304-DISP Display Module (see Figure 1-3). This remote display module includes all front panel instrument controls/features (with the exception of power). All features/menus work as described for the Model 2306 (exceptions are noted). A 9 foot cable attaches the remote display to the rear of the power supply allowing the unit to be operated remotely.

Figure 1-3
Remote display option

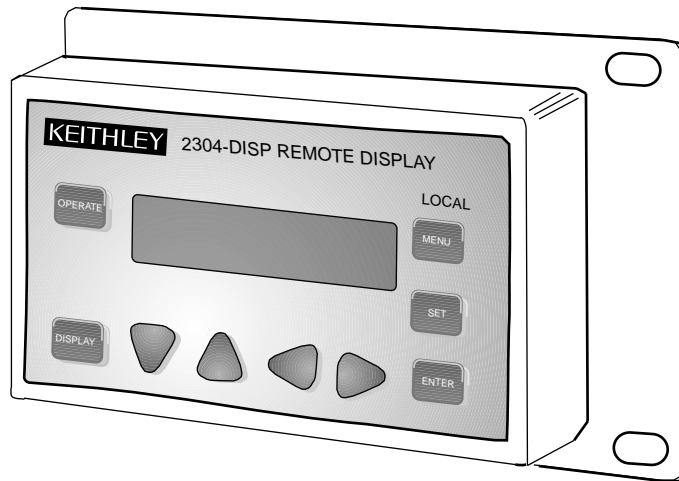

NOTE When using the 2304-DISP remote, VFD BRIGHTNESS may not appear in the main menu (dependent on the firmware revision in the 2304-DISP).

Plug the remote display module into the rear panel connector labeled “REMOTE DISPLAY OPTION” (see rear panel in Figure 1-1). When plugged in, the main display module is disabled with the following message displayed:

```
REMOTE PANEL
ENABLED
```

When the remote display module is unplugged, control returns to the main display module.

NOTE When connecting or disconnecting the 2304-DISP remote display, allow a few seconds for the power supply to recognize the action. Fast, repeated connects/disconnects of the remote display may cause the power supply to hang or appear to hang. Disconnecting the remote display and waiting a few seconds to reconnect it may clear the problem. If not, cycling power on the power supply clears the condition.

Power-up

Line power connection

The power supply operates from a line voltage in the range of 100-120VAC/200-240VAC at a frequency of 50 or 60Hz. Line voltage and frequency are automatically sensed, therefore there are no switches to set. Check to see that the line power in your area is compatible. Use the :SYS-Tem :LFRrequency? query (Section 10) to read the line frequency.

Perform the following steps to connect the power supply to the line power and turn it on:

WARNING The power cord supplied with the Model 2306 contains a separate ground for use with grounded outlets. When proper connections are made, instrument chassis is connected to power line ground through the ground wire in the power cord. Failure to use a grounded outlet may result in personal injury or death due to electric shock.

1. Before plugging in the power cord, make sure the front panel power switch is in the off (0) position.
2. Connect the female end of the supplied power cord to the AC receptacle on the rear panel.
3. Turn on the power supply by pressing the front panel power switch to the on (1) position.

Power-up sequence

On power-up, the power supply performs self-tests on its RAM and EPROM. After a blinking cursor appears on line one, RAM tests are completed. After a blinking cursor appears on line two, EPROM self tests are completed.

NOTE *If a problem develops while the instrument is under warranty, return it to Keithley Instruments Inc., for repair.*

If the instrument passes the self tests, the following information is briefly displayed:

- **Top line** — The model number and the IEEE-488 address are displayed. (The factory default GPIB address is 16.)
- **Bottom line** — Firmware revision levels are displayed for the main board and the display board. Also displayed is the detected line frequency.

After displaying the above information, any errors that occurred during the startup sequence will be displayed. Then, the instrument goes to the default settings or the saved power up settings (*RST or SAV0-4) display type with the output off (see “Default settings” on page 1-10). Any missed error messages may be viewed over the bus using the :SYST:ERR? (see “Error Queue” in Section 7).

NOTE *For the Model 2306-PJ, the saved power up settings available are from SAV0-SAV3.*

Fuse replacement

A rear panel fuse protects the power line input of the power supply. If the line fuse needs to be replaced, perform the following steps:

1. Power off the unit and remove line cord.
2. The fuse drawer is located on the left side of the AC receptacle (see Figure 1-4). On the right side of the fuse drawer is a small tab. At this location, use a thin-bladed knife or screwdriver to pry the fuse drawer open.
3. Slide the fuse drawer out to gain access to the fuse. Note that the fuse drawer does not pull all the way out of the power module.
4. Snap the fuse out of the drawer and replace it with the same type (250V, 2.0A, 5 × 20mm time lag). The Keithley part number is FU-81.

CAUTION For continued protection against fire or instrument damage, only replace the fuse with the type and rating listed. If the instrument repeatedly blows fuses, locate and correct the cause of the problem before replacing the fuse.

5. Push the fuse drawer back into the power module.

Figure 1-4
Fuse drawer location

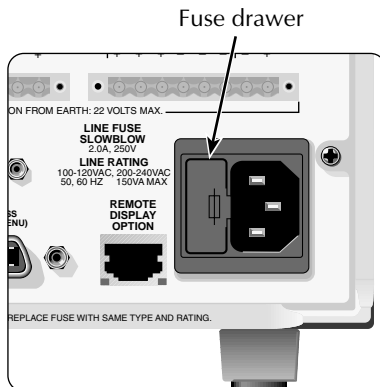

Display modes

For voltage and current readings, there are four display modes described as follows:

- **ACTUAL V AND I** — This display mode is used to read back the actual output voltage and current. This display mode is the RST default. (See Section 2 for details.)
- **DVM INPUT** — This mode is used to display the DC voltage applied to the DVM input of the power supply. (See Section 2 for details.)
- **PULSE CURRENT** — This mode is used to display high, low, or average pulse-current measurements. (See Section 3 for details.)
- **LONG INTEGRATION** — This mode is used to display average current measurements of a pulse or pulses measuring periods between 850msec to 60sec (60 Hz line frequency) and 840msec to 60sec (50 Hz line frequency). (See Section 4 for details.)

Any one of the four display modes can be the power-on default. Use the **SAVE SETUP** item of the **MENU** to save the selected display mode in memory, and use the **POWER ON SETUP** item to specify the power-on setup (see “Setups — Save, Power-on, and Recall” on page 1-12 for details). A display mode is selected as follows:

1. Press the **DISPLAY** key and use the **▲** or **▼** key to display the desired mode: **ACTUAL V AND I**, **DVM INPUT**, **PULSE CURRENT**, or **LONG INTEGRATION**.
DISPLAY TYPE #1 or **DISPLAY TYPE #2** will be shown on the top line of the display.

***NOTE** DISPLAY TYPE #1 is the display mode for the Battery Channel while DISPLAY TYPE #2 is the display mode for the Charger Channel.*

2. Toggle active channel using the **◀** or **▶** keys.

***NOTE** If active channel is changed back to the original channel, the initial settings are displayed.*

3. With the desired mode and active channel displayed, press **ENTER**. Now the display will reflect this desired mode and active channel. Note that after selecting **PULSE CURRENT**, use the **▲** or **▼** key to select the desired pulse measurement: pulse high, pulse low, or pulse average. Examples of the display modes are shown as follows:

Table 1-1
Display samples

Display mode	Samples for Channel #1 (Battery)	Samples for Channel #2 (Charger)	Reference
Actual V and I:	6.116 V #1 ON 1.2058 A	6.116 V #2 ON 1.2058 A	Section 2
DVM input:	DVM INPUT #1 OFF 4.993 V	DVM INPUT #2 OFF 4.993 V	Section 2
Pulse current:	PULSE HI #1 ON 2.1947 A	PULSE HI #2 ON 2.1947 A	Section 3
	PULSE LO #1 ON 0.2147 A	PULSE LO #2 ON 0.2147 A	
	PULSE AVG #1 ON 1.1495 A	PULSE AVG #2 ON 1.1495 A	
Long integration:	LONG INT #1 ON 1.0236 A	LONG INT #2 ON 1.0236 A	Section 4

NOTES “#1” or “#2” indicates present active channel. “ON” indicates that the output is turned on. With the output turned off, “OFF” is displayed. See Section 2 for details on outputting current and voltage.

“NO PULSE” is displayed if the output is OFF or pulses are not detected (output ON) for pulse current and long integration display modes only.

When a change is made that affects the readings being taken, dashes are displayed instead of readings. The dashes remain until a valid reading for the new condition is taken.

Default settings

The power supply can be set to power-on with the factory default conditions (RST defaults) or to user-saved setup conditions. The factory default conditions are listed in Table 1-2.

Table 1-2
Factory defaults (RST)

Setting	Reset (RST) default	
	Battery Channel (#1)	Charger Channel (#2)
Output value settings:		
Voltage (V)	0.000V	0.000V
Current (A)	0.2500A	0.2500A
Output state (operate)	OFF	OFF
Voltage protection	8V, clamp off	8V, clamp off
Display type	Actual V and I	Actual V and I
GPIB address*	No effect (factory set to 16)	
Current range	5 amps (Auto Range OFF)	5 amps (Auto Range OFF)
Integration rate	1.00 PLC	1.00 PLC
Average readings	1	1
Power on setup*	No effect (factory set to RST)	
Current limit mode	LIM	LIM
Output relay one*	No effect (after power cycle, set to zero)	
Output relay two*		
Output relay three*		
Output relay four*		
VFD brightness*	Over bus: 1	From display: FULL BRIGHTNESS
Output bandwidth	LOW**	HIGH
Output impedance	0.00Ω	<i>Not Applicable</i>
Pulse current:		
High time	33 μsec	33 μsec
Low time	33 μsec	33 μsec
Average time	33 μsec	33 μsec
Average readings	1	1
Trigger delay	0.00000 sec	0.00000 sec
Trigger level:	Model 2306 & 2306-PJ	Model 2306-PJ
Range	5A Current range	500mA Current range
	5A (Full scale)	500mA (Full scale)
	5A 0.000A	500mA 0.0000A
	1A 0.000A	100mA 0.0000A
	100mA 0.0000mA	10mA 0.0000A
		<i>Not Applicable</i>
		<i>Not Applicable</i>
		<i>Not Applicable</i>
Long integration:		
Integration time	1 second	1 second
Pulse timeout	16 seconds	16 seconds
Trigger edge	RISING	RISING
Trigger level	Same as “Trigger level” (above)	Same as “Trigger level” (above)

*Global settings (not channel specific).

**Default is HIGH for firmware version B02 and lower.

Setups — Save, Power-on, and Recall

Setups are configured by SAVE SETUP, POWER ON SETUP and RECALL SETUP items of the MENU (which is accessed by pressing the MENU key). When a setup is saved, all settings that are channel specific settings will be saved to that setup. Saving/recalling a setup has no effect on Global Settings (see Global settings in Table 1-2 on page 1-11.) Similarly, recalling a setup loads only the channel specific parameters from that setup.

NOTE Table 1-3 shows the menu structure. Rules to navigate the menu follow the table.

The setup MENU items are explained as follows:

NOTE For the Model 2306-PJ, the memory location settings available are from SAV0-SAV3 (SAV4 is not available).

- **SAVE SETUP** - Save the present power supply setup to a memory location; SAV0-SAV4.
- **RECALL SETUP** - Return the power supply to the RST defaults (Table 1-2 on page 1-11), or to one of the user saved setups; SAV0-SAV4. Note the operate state (output) is always recalled as OFF.
- **POWER-ON SETUP** - Select the setup to use at power-up; RST, SAV0-SAV4 (output off).

When powering up to the SAV0, SAV1, SAV2, SAV3, or SAV4 setup, the output will be OFF regardless of the operate state when the setup was saved. For example, if the output is ON when the setup is saved as SAV0, the power supply will power up with the output OFF for the SAV0 power-on setup.

NOTE For GPIB operation, the setups are saved and recalled using the *SAV, *RCL, and *RST commands. (See Section 8 for details.) The power-on setup is selected using the *SYSTEM:POSetup* command (Section 10).

Menu

Many aspects of operation are configured from the menus summarized in Table 1-3. Use the rules following the table to navigate through the menu structure.

NOTE The menu key is used to access the menu structure. However, if in remote for IEEE-488 bus operation (“R” displayed below “ON/OFF”) the menu key returns the instrument to LOCAL operation.

Table 1-3

Main MENU structure (accessed by pressing the MENU key on the Front Panel)

Menu item	Description	Ref												
GPIB ADDRESS	Set primary address (0 to 30)	Sect. 6												
CURRENT RANGE #1/#2	Select current range: Battery channel (#1) <table border="0"> <tr> <td><u>Model 2306</u></td> <td><u>Model 2306-PJ</u></td> <td><u>Charger channel (#2)</u></td> </tr> <tr> <td>5A</td> <td>5A</td> <td>5A</td> </tr> <tr> <td>5mA</td> <td>500mA</td> <td>5mA</td> </tr> <tr> <td>AUTO</td> <td>AUTO</td> <td>AUTO</td> </tr> </table>	<u>Model 2306</u>	<u>Model 2306-PJ</u>	<u>Charger channel (#2)</u>	5A	5A	5A	5mA	500mA	5mA	AUTO	AUTO	AUTO	Sect. 2
<u>Model 2306</u>	<u>Model 2306-PJ</u>	<u>Charger channel (#2)</u>												
5A	5A	5A												
5mA	500mA	5mA												
AUTO	AUTO	AUTO												
NPLC RATE #1/#2	Set integration rate in NPLC (0.01 to 10)	Sect. 2												
AVER READINGS #1/#2	Set average reading count (1 to 10)	Sect. 2												
SAVE SETUP	Save present setup in memory (SAV0–SAV4)	Note 1												
RECALL SETUP	Recall setup from memory (RST, SAV0–SAV4)	Note 1												
POWER ON SETUP	Select power-on setup (RST, SAV0–SAV4)	Note 1												
CALIBRATE UNIT	Calibrate unit (see calibration sections)													
VOLT PROTECT #1/#2	Set voltage protection range (0–8V) and clamp (ON/OFF) in this manual	Sect. 2												
CURR LIM MODE #1/#2	Select current limit mode (LIMit or TRIP)	Note 2												
OUTPUT RELAYS	Close (1) or open (0) relay control circuitry (relays 1–4)	Sect. 5												
REVISION NUMBER	Display firmware revision levels	Note 2												
SERIAL NUMBER	Display serial number of the power supply	Note 3												
VFD BRIGHTNESS	Set VFD display's brightness level (OFF, FULL, 3/4, 1/2, 1/4)	Sect. 10												
OUT BANDWIDTH #1/#2	Set bandwidth (HIGH, LOW)	Sect. 2												
OUT IMPEDANCE #1	Set battery channels impedance (0–1 Ω)	Sect. 2												
PULSE CURRENT #1/#2	Pulse-current configuration.	Sect. 3												
HIGH TIME	Set high time integration rate (in μsec.).													
LOW TIME	Set low time integration rate (in μsec.).													
AVERAGE TIME	Set average time integration rate (in μsec.).													
AUTO TIME	Set pulse integration rates automatically.													
PULSE TIMEOUT	Set pulse timeout (default is 1.000 second, incremented in 1ms steps).													
AVERAGE READINGS	Set average reading count (1 to 100).													
TRIGGER DELAY	Set trigger delay in seconds (0 to 100msec).													
TRG LEV mA RANGE	Model 2306-PJ — Set battery channel (#1) trigger level range on the 500mA current range (500mA, 100mA, 10mA).													
TRG LEVEL mA	Model 2306-PJ — Set pulse current trigger level in A on the 500mA current range: <table border="0"> <tr> <td><u>Battery channel (#1)</u></td> <td><u>Charger channel (#2)</u></td> </tr> <tr> <td>mA(500mA) 0–500mA</td> <td>Use TRIGGER LEVEL menu</td> </tr> <tr> <td>mA(100mA) 0–100mA</td> <td>item (charger channel supports</td> </tr> <tr> <td>mA(10mA) 0–10mA</td> <td>5A current range only)</td> </tr> </table>	<u>Battery channel (#1)</u>	<u>Charger channel (#2)</u>	mA(500mA) 0–500mA	Use TRIGGER LEVEL menu	mA(100mA) 0–100mA	item (charger channel supports	mA(10mA) 0–10mA	5A current range only)					
<u>Battery channel (#1)</u>	<u>Charger channel (#2)</u>													
mA(500mA) 0–500mA	Use TRIGGER LEVEL menu													
mA(100mA) 0–100mA	item (charger channel supports													
mA(10mA) 0–10mA	5A current range only)													
TRIG LEV RANGE	Model 2306 and 2306-PJ — Set battery channel (#1) trigger level range (5A, 1A, 100mA) on the 5A current range.													

Table 1-3 (cont.)

Main MENU structure (accessed by pressing the MENU key on the Front Panel)

Menu item	Description	Ref
TRIGGER LEVEL	Model 2306 and 2306-PJ — Sets pulse current trigger level in Amps on the 5A current range: <u>Battery channel (#1)</u> <u>Charger channel (#2)</u> A(5.0) 0–5A A(5.0) 0–5A A(1.0) 0–1A mA(100) 0–100mA	
LONG INTEGRAT #1/#2 INTEGRATION TIME AUTO TIME PULSE TIMEOUT TRIGGER EDGE TRG LEV mA RANGE TRG LEVEL mA TRIG LEV RANGE TRIGGER LEVEL	Long integration configuration. Manually set integration time (up to 60 sec). Automatically set integration time. Set the “NO PULSE” timeout period (1 to 63 sec). Select trigger edge (rising, falling or neither). Model 2306-PJ — Set battery channel (#1) trigger level range on the 500mA current range (500mA, 100mA, 10mA). Model 2306-PJ — Set pulse current trigger level in mA on the 500mA current range: <u>Battery channel (#1)</u> <u>Charger channel (#2)</u> mA(500mA) 0–500mA Use TRIGGER LEVEL menu mA(100mA) 0–100mA item (charger channel supports mA(10mA) 0–10mA 5A current range only) Model 2306 and 2306-PJ — Set battery channel (#1) trigger level range (5A, 1A, 100mA) on the 5A current range. Model 2306 and 2306-PJ — Sets long integration trigger level in Amps on the 5A current range: <u>Battery channel (#1)</u> <u>Charger channel (#2)</u> A(5.0) 0–5A A(5.0) 0–5A A(1.0) 0–1A mA(100) 0–100mA	Sect. 4

- Notes: 1. See “Default settings” on page 1-10 in this section to save and recall setups. For the Model 2306-PJ, the memory location settings available are from SAV0-SAV3 (SAV4 is not available).
2. Revision Number displays the firmware revision level for the microcontroller and the display.
3. Serial Number displays the serial number of the power supply.

Getting around the MENU

- Press the MENU key to activate the menu.
- Use the ▲ and ▼ keys to scroll through the primary menu items.
- Changing channels: When the main menu is displayed, use the ◀ and ▶ keys to change the active channel (each press of the ◀ and ▶ keys will toggle between Channel #1 and Channel #2).

NOTE *If a channel number is not shown, the ◀ and ▶ key presses will be ignored. Also the ◀ and ▶ key presses will be ignored if a sub-menu only exists on the battery channel (not on the charger channel).*

- The active channel may be changed in the main menu, and the top sub-menus for pulse current and long integration. The active channel cannot be changed in all other sub-menus.
- Select the displayed primary menu item by pressing ENTER. With PULSE CURRENT or LONG INTEGRATION selected, use the ▲ and ▼ keys to display the secondary items. (Again, pressing ENTER selects the displayed item.)

NOTE *Before pressing enter, make sure the desired channel is active. If ENTER is pressed with the incorrect channel selected, press the MENU key (to cancel changes), use ◀ or ▶ to toggle to the desired channel, and then press ENTER to select the displayed primary menu item.*

- Display and change settings and selections (for a menu item) using the edit keys (◀ ▶ ▲ ▼):

For a setting, use ◀ or ▶ to place the cursor on the desired digit, then use the ▲ and ▼ keys to increase or decrease the value (unless noted otherwise).

Rapid jump to minimum or maximum: To rapidly jump to the maximum value, increment the most significant digit (the left further-most digit). (Note that if the tens digit is the most significant but is not displayed, place the cursor to the left of the units digit.) To rapidly jump to the minimum value, decrement the first leading zero (or tens digit if there is not a leading zero).

For a selection, use the ▲ or ▼ keys to display the desired option (unless noted otherwise).

- With the desired setting or selection displayed, press ENTER for it to take effect. Pressing MENU will cancel the edit operation.
- Use the MENU key to back out of the MENU structure.

SCPI programming

SCPI programming information is integrated with front panel operation throughout this manual. SCPI commands are listed in tables, and additional information that pertains exclusively to remote operation is provided after each table. Also, the SCPI tables may reference other sections of this manual.

NOTE Except for Section 11, all SCPI tables in this manual are abridged. That is, they exclude most optional command words and query commands. Optional command words and query commands are summarized as follows.

Optional command words — In order to be in conformance with the IEEE-488.2 standard, the power supply accepts optional command words. Any command word that is enclosed in brackets ([]) is optional and does not have to be included in the program message.

Query commands — Most command words have a query form (exceptions are noted). A query command is identified by the question mark (?) that follows the command word. A query command requests (queries) the programmed status of that command. When a query is sent and the power supply is addressed to talk, the response message is sent to the computer.

To send a SCPI command as a query, append a “?” to the fundamental form of the command. (Make sure to add the “?” immediately following the command on the same line.)

NOTE For complete details, see “Programming syntax” in Section 6.

2

Basic Power Supply Operation

- **Test connections** — Explains how to connect DUT to the power supply output and how to connect an external voltage to the DVM input.
- **Outputting voltage and current** — Explains how to output voltage and current.
- **Output bandwidth** — Details Model 2306 output bandwidth control.
- **Output impedance** — Details Model 2306 variable output impedance feature.
- **SCPI Programming — outputting voltage and current** — Contains SCPI commands related to output voltage and current.
- **Reading back V and I** — Covers the actual V and I display mode, which is used to measure and display the actual voltage and current being delivered to the DUT.
- **SCPI Programming — measure V and I, and DVM input** — Contains SCPI commands related to measuring voltage and current.
- **Independent voltage measurements (DVM)** — Explains how to use the digital voltmeter (DVM) to make DC voltage measurements.
- **SCPI Programming — DVM** — Contains SCPI commands related to DVM measurements.
- **Sink operation** — Explains how to use the power supply to dissipate power, rather than sourcing it.
- **Programming examples** — Provides two examples: one to output and read back voltage and current, and one to measure the DVM input.

NOTES *This manual covers Keithley Models 2302, 2302-PJ, 2306, and 2306-PJ simulators (power supplies). Since the Model 2302 and 2302-PJ are single channel battery simulators, functions related to the second channel (i.e., the charger channel) are not available for the Model 2302 and 2302-PJ. Therefore:*

- *battery and charger channel features contained in this manual apply for the Model 2306 and 2306-PJ*
- *only battery channel features contained in this manual apply for the Model 2302 and 2302-PJ*

Refer to Appendix F for specific Model 2302 and 2302-PJ information.

Information contained in this section applies to all power supply channels (unless otherwise noted). In this manual, channel 1 refers to the battery channel while channel 2 refers to the charger channel (2306 and 2306-PJ feature only).

Test connections

WARNING **When installing a unit into a test system, make sure the external power sources do not apply voltage to the power supply in excess of its maximum limits (see specifications). Failure to do so could result in personal injury or death.**

Test connections to the power supply are made at the rear panel using a quick disconnect OUTPUT/DVM IN connector (see rear panel in Figure 1-1 for connector location). Use up to #14 AWG wire for the screw terminals of the connector. Once the connector is wired up, plug it into the rear panel and tighten the captive retaining screws.

Figure 2-1 shows four wire sense power supply connections to the DUT.

Figure 2-1
Four-wire sense connections for battery and charger channels

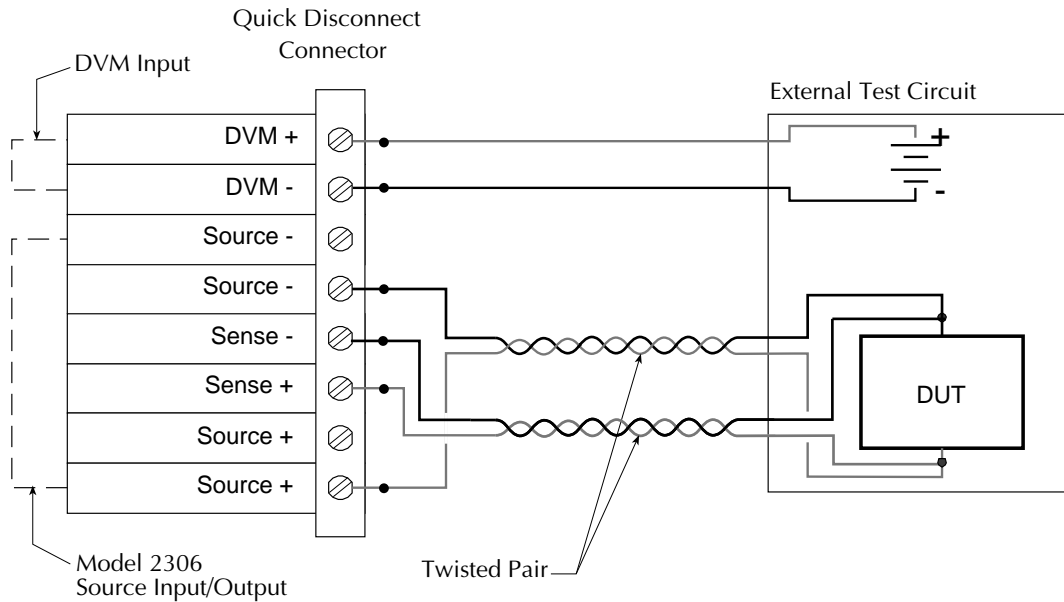

Remote sense

As shown in Figure 2-1 the 2306 battery and charger channels are intended to be operated with remote sense leads (4 wire connection). The Sense+ and Sense- pins provide output voltage sensing. Without these terminals connected, the power supply operates without voltage feedback and therefore supplies an unregulated voltage. This unregulated voltage value can be up to +18V or down to -5V. Use voltage protection to turn off the output and protect against the extremes (refer to “Setting voltage protection value” on page 2-5).

Connect the sense inputs to the supply as close as possible to the load’s source inputs through twisted pair leads (refer to Figure 2-1). This is necessary to achieve the maximum transient performance of the supply.

NOTE Do NOT jumper the sense inputs and supply outputs at the rear of the supply! Connecting the sense leads in this fashion will severely compromise the performance of Model 2306 with dynamic loads when using 4-wire sense.

Local sense

The 2306 battery and charger channels can be connected to operate with local sense leads (2-wire connection) as shown in Figure 2-2. In this connection scheme, the sense inputs and supply outputs are jumpered at the rear of the supply.

Figure 2-2
Local sense connections

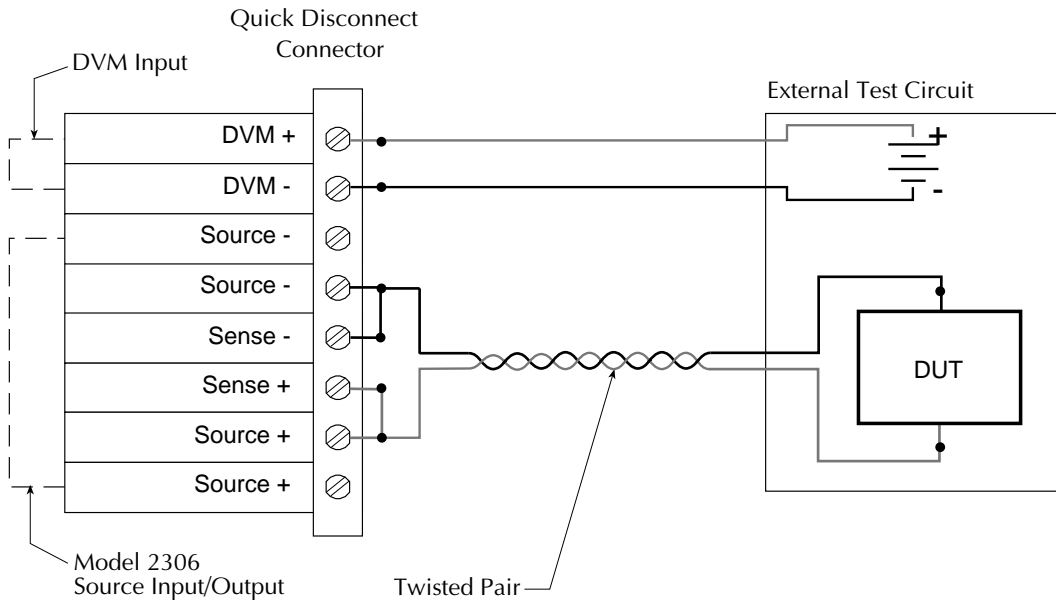

Outputting voltage and current

Setting voltage protection value

NOTE *The VPT value (voltage protection value) is channel specific. The number after the # indicates the channel affected by editing.*

Voltage protection circuitry (VPT) is provided for the battery and charger channels. This function monitors the SOURCE + pins (see Figure 2-1 on page 2-3 or Figure 2-2 on page 2-4) with respect to the 2306's internal ground and will shut off the output voltage for either channel when the protection voltage range (which equals the set voltage \pm protection voltage) set by the user is exceeded. This voltage is typically not the same voltage as at the device under test due to lead impedance and internal sense resistor losses. VPT circuitry is useful in protecting the load from a high positive voltage if one of the remote sensing leads is disconnected. When in VPT mode, the output is held in the Operate OFF position until an Operate ON command is received (VPT will be displayed until the output is turned back on). The voltage protection feature has a clamp setting, which can be turned ON or OFF. If ON, protection voltage values below 0 volts (-0.6 volts) are not allowed. If OFF, protection voltage can go negative to the extent of the set voltage - protection voltage.

For example: If PROT=4V, and SET =6V, VPT range is from +2V to +10V. If the SET voltage is changed to 2V and protection clamp set to OFF, the range would equal -2V to +6V. However, if protection clamp is set to ON, the range would equal -0.6V to +6V.

NOTE *Table 1-3 shows the menu structure. Rules to navigate the menu follow the table.*

NOTE *Electrostatic Discharge (ESD) to the output connector pins may cause the VPT circuitry to turn the output off. Use proper ESD handling precautions before making any contact with the output connector pins or wires connected to the pins.*

Procedure

To set the VPT value from the front panel:

1. Press the MENU key to access the main menu.
2. Select VOLT PROTECT #1 or #2 by scrolling through the primary menu items (use the ▲ and ▼ keys to scroll). Scroll until VOLT PROTECT is displayed on the bottom line.
3. Select channel for VPT. Toggle between VOLT PROTECT #1 or #2 using the ◀ and ▶ keys.
4. Press ENTER.
5. Use the ▲, ▼, ◀ and ▶ keys to key in the desired VPT value and to select cOFF (voltage protection clamp OFF) or cON (voltage protection clamp ON). Setting changes can be canceled by pressing MENU.
6. Press ENTER to save and return to main menu.

Selecting proper current range

NOTE The current range value is channel specific. The number after the # indicates the channel affected by editing.

Power supply current ranges are listed in Table 2-1. With auto range selected, the instrument will automatically go to the most sensitive range to perform the measurement. The current range setting may be the same or different for each channel.

Table 2-1
Current ranges

Power supply	Current ranges
Model 2306	5A, 5mA or AUTO
Model 2306-PJ:	
Battery channel (#1)	5A, 500mA, or AUTO
Charger channel (#2)	5A, 5mA, or AUTO

NOTE Table 1-3 (in Section 1) shows the menu structure. Rules to navigate the menu follow the table.

Procedure

To select the CURRENT RANGE from the front panel:

1. Press the MENU key to access the main menu.
2. Select CURRENT RANGE #1 or #2 by scrolling through the primary menu items (use the ▲ / ▼ keys to scroll). Scroll until CURRENT RANGE is displayed on the bottom line.
3. Select channel for CURRENT RANGE. Toggle between CURRENT RANGE #1 or #2 using the ◀ / ▶ keys. The “#1” (battery channel active) or “#2” (charger channel active) will appear on the bottom line of the display.
4. Press ENTER.
5. Use the ▲ / ▼ keys to display the desired current range value. Setting changes can be canceled by pressing MENU.
6. Press ENTER to save and return to main menu.

Selecting current limit mode

NOTE The current limit mode setting is channel specific. The number after the # indicates the channel affected by editing.

If the current limit is reached, the output will either turn off (TRIP) or stay on (LIM). The two current limit modes (LIM or TRIP) are explained as follows:

LIM mode - With LIM mode selected, the output will remain on when the current limit is reached. The “LIM” message will appear on the lower line of the display after the current reading indicator (A or mA). The message will clear when the limit condition is cleared.

The power supply may or may not be taken out of current limit by decreasing the output voltage or increasing the current limit value, depending on how the circuit is connected. However, increasing the current limit may compromise protection for the DUT.

While in the current limit, the power supply is operating as a constant-current source. As long as the limit condition exists, the power supply output current will remain constant. The output voltage is probably less than the programmed value when sourcing current, and probably greater than the programmed value when sinking current.

TRIP mode - With TRIP mode selected, the output will turn off when the current limit is reached. The “TRIP” message will appear on the lower line of the display after the current reading indicator (A or mA). The message will clear when the output is turned back on, assuming it does not trip again due to a current limit condition.

NOTE Table 1-3 shows the menu structure. Rules to navigate the menu follow the table.

Procedure

To select the CUR LIM MODE from the front panel:

1. Press the MENU key to access the main menu.
2. Select CUR LIM MODE #1 or #2 by scrolling through the primary menu items (use the ▲ / ▼ keys to scroll). Scroll until CUR LIM MODE is displayed on the bottom line.
3. Select channel for CUR LIM MODE. Toggle between CUR LIM MODE #1 or #2 using the ◀ / ▶. The “#1” (battery channel active) or “#2” (charger channel active) will appear on the bottom line of the display.
4. Press ENTER.
5. Use the ▲ / ▼ keys to display the desired current limit mode (LIM or TRIP). Setting changes can be canceled by pressing MENU.
6. Press ENTER to save and return to main menu.

Editing output voltage and current limit values

NOTE Output voltage and current limit values are channel specific. The number after the # indicates the channel affected by editing.

Current limit is a feature that protects the load from damage under overload conditions. The current limit setting indicates the maximum amount of current allowed to flow through the system. The setting applies to any of the current range settings. For the Model 2306, the current range settings are 5A, 5mA, or AUTO. On the Model 2306-PJ, the current range settings are: 5A, 500mA, or AUTO (do not apply more than 600mA on the 500mA range).

The current limit setting for the 5 AMPS and AUTO ranges is “remembered” by that range. For the following examples, assume the current limit setting on the 5 amps range is 3A. Selecting the 5 MILLIAMPS range defaults the current limit setting to 1A since that is the maximum allowable setting on that range. Toggling back to the 5 amps range reinstates the 3A limit. If the current limit value on the 5 amps range is \leq 1A, the limit on the 5mA range will be the same when switching from the 5A range to the 5mA range. Selecting the 500mA range (Model

2306-PJ) defaults the current limit setting to 600mA since that is the maximum allowable setting on that range. Toggling back to the 5 amps range reinstates the 3A limit. If the current limit value on the 5 amps range is $\leq 600\text{mA}$, the limit on the 500mA range will be the same when switching from the 5A range to the 500mA range.

NOTE Table 1-3 shows the menu structure. Rules to navigate the menu follow the table.

Procedure

To edit voltage and current values from the front panel:

NOTE The following procedure assumes that the appropriate current range is already selected along with current limit mode and voltage protection.

1. Press the SET key to select the output settings mode. A blinking cursor appears in the voltage field of the display.
2. Use the ▲, ▼, ◀ and ▶ keys to key in the desired output voltage value.
 - Cursor position (blinking digit) is controlled by the ◀ and ▶ keys.
 - With the cursor positioned on a digit, increment or decrement the value using the ▲ and ▼ keys.
3. Press SET to move the blinking cursor to the current limit field.
4. Use the ▲, ▼, ◀ and ▶ keys to key in the desired current limit.
5. Press SET to exit from output settings mode.

NOTE Once in Set Mode (enter Set Mode by pressing the SET key), the active channel cannot be changed. If Set Mode was inadvertently entered or entered in on the wrong channel, press the SET key until the blinking cursor disappears to exit Set Mode (once out of Set Mode, active channel switching is enabled).

Editing voltage and current values using the SET key cannot be canceled with the MENU key (the values are immediately committed). Enter the old values by repeating the editing procedure and manually using the ▲, ▼, ◀ and ▶ keys to key in the desired output voltage or current value(s).

NOTE SET key: This key is active in any front panel menu or display mode — if not already in the output settings mode, the SET key will select it.

Pressing SET to exit the output settings mode returns the instrument to the previous display mode or front panel menu.

V and I DACs are updated in real time — if the output is on, the output is updated immediately when a value is altered.

Editing shortcuts

With the output OFF, the following editing shortcuts can be used:

- Output voltage can be quickly set to the maximum value by incrementing the tens digit (MSD). Note that if the tens digit is zero, it is not displayed. Place the cursor to the left of the units digit.
- Output voltage can be quickly set to zero (0.000V) by decrementing the first leading zero of the reading. If there is no leading zero, decrement the tens digit.
- Current limit can be quickly set to its maximum value by incrementing the units digit (MSD).
- Current limit on either range can be quickly set to the minimum value 0.006A by decrementing the first leading zero of the reading. If there is no leading zero, decrement the units digit.

Editing restrictions

With the output ON, the following editing restrictions are in effect:

- You cannot increment a digit that would display a value that jumps to the maximum. For example, for the value 14.200 V, you cannot increment the “1” or the “4” since the resultant value would exceed 15.000 V.
- When decrementing a digit, only that digit and digits to the left are affected. The digits to the right of the cursor are not changed.

Pressing operate

NOTE Pressing OPERATE is channel specific. The number after the # indicates the channel affected by the OPERATE key.

Use the OPERATE key to control power supply output. This key toggles the output ON and OFF for the active channel even if output status is not displayed. To display the output status for the active channel, place the unit in readings or set mode (the output status is not shown in display type menu, main menu, or submenus). When output status is displayed, ON or OFF will appear in the upper right hand corner of the display.

NOTE DVM measurements can be performed with the output off.

Output bandwidth

The battery and charger channel’s output bandwidth control has HIGH and LOW settings. The HIGH setting will result in the fastest response with dynamic loads but, could be unstable with certain loads. The LOW setting mode will have a slower response but will be stable for most loads.

Testing the performance of the battery charger circuitry in a handset does not require the high bandwidth performance in channel #1 or channel #2 of the Model 2306. Since a charger circuit is a voltage regulated circuit, it resembles a high capacitance load to the output of the 2306. For this type of application, the LOW bandwidth output mode provides increased stability and eliminates oscillations that may occur.

To use this setting, there are two requirements: output has to be on and the current range has to be set to 5A. If the output is off or the current range is not 5A, output bandwidth is set to low. This is summarized in Table 2-2.

Table 2-2
Output bandwidth setting for a channel

Output	Current	Bandwidth
ON	5A	LOW or HIGH (user selectable)
OFF	5mA or 5A	LOW
OFF/ON	5mA	LOW

NOTE *The 5mA current range (Table 2-2) may be selected from the front panel, over the bus, or through autoranging.*

Procedure

NOTE *This procedure assumes that the appropriate current range is already selected along with current limit mode and voltage protection.*

To set output bandwidth from the front panel:

1. Press the MENU key to access the main menu.
2. Select OUT BANDWIDTH #1 or #2 by scrolling through the primary menu items (use the ▲ and ▼ keys to scroll). Scroll until OUT BANDWIDTH is displayed on the bottom line.
3. Select channel for bandwidth. Toggle between OUT BANDWIDTH #1 or #2 using the ◀ and ▶ keys.
4. Press ENTER.
5. Use the ▲ and ▼ keys to set the desired bandwidth setting (HIGH or LOW). Setting changes can be cancelled by pressing MENU.
6. Press ENTER to save and return to main menu.

Output impedance

Keithley's Model 2306 has a variable output impedance feature on the battery channel (channel #1). This output impedance setting allows the performance of the battery channel to closely model a real battery's performance with a dynamic load. When setting the output impedance to a certain value (R_I), the output voltage drop will be proportional to the output current (see voltage drop equation). The output voltage will be reduced by the voltage drop.

Voltage drop equation

$$V_{drop}(t) = R_I \times I(t)$$

NOTE *For a more detailed discussion of output impedance and the performance with various types of loads, see the Applications Guide contained in Appendix E of this manual.*

Changing the battery channel's output impedance

The Model 2306's output impedance can be checked or changed with the output on or off. The output impedance is selectable from 0.00Ω to 1.00Ω in 10 milli- Ω steps (default is 0Ω).

Procedure

NOTE *The following procedure assumes that the appropriate current range is already selected along with current limit mode and voltage protection.*

To set output impedance from the front panel:

1. Press the MENU key to access the main menu.
2. Using the ◀ and ▶ keys, toggle channel indicator until #1 is displayed. (Bandwidth is channel #1 only feature.)
3. Select OUT IMPEDANCE #1 by scrolling through the primary menu items (use the ▲ and ▼ keys to scroll). Scroll until OUT IMPEDANCE is displayed on the bottom line.
4. Press ENTER.
5. Use the ▲ and ▼ keys to set the desired bandwidth setting (HIGH or LOW). Setting changes can be canceled by pressing MENU.
6. Press ENTER to save and return to main menu.

SCPI programming — outputting voltage and current

The commands to output voltage and current are summarized in Table 2-3 (a listing following the table contains specific command notes). The programming example (“Outputting and reading back V and I”) located at the end of this section demonstrates how to use these commands.

NOTE Brackets [] indicate optional (and default) command parameters.

Table 2-3
SCPI command summary — outputting voltage and current

Commands	Description	Default
SENSE[1] :CURRent :RANGe [:UPPer] <n> :AUTO 	SENSE[1] subsystem for Channel #1 (battery channel): Current function: Set current measurement range: Specify expected current in amps: 0 to 5. Enable or disable auto range.	5.0 OFF
SENSE2 :CURRent :RANGe [:UPPer] <n> :AUTO 	SENSE2 subsystem for Channel #2 (charger channel): Current function: Set current measurement range: Specify expected current in amps: 0 to 5. Enable or disable auto range.	5.0 OFF
[SOURce[1]] :VOLTage <n> :PROTection <NRf> :STATe? :CLAMp :CURRent <n> :TYPe <name> :STATe?	[SOURce1] subsystem for Channel #1 (battery channel): Set voltage amplitude in volts: 0 to 15 (1mV resolution). Sets VPT (voltage protection) range (0–8V). Query state of VPT—no associated command. Sets VPT clamp mode ON or OFF. Set current limit value in amps: 0.006 to 5 (100µA res) Select current limit type: LIMit or TRIP. Query state of current limit—no associated command.	0.0 8V OFF 0.25 LIM
SOURce2 :VOLTage <n> :PROTection <NRf> :STATe? :CLAMp :CURRent <n> :TYPe <name> :STATe?	SOURce2 subsystem for Channel #2 (charger channel): Set voltage amplitude in volts: 0 to 15 (1mV resolution). Sets VPT range (0–8V). Query state of VPT—no associated command. Sets VPT clamp mode ON or OFF. Set current limit value in amps: 0.006 to 5 (100µA res). Select current limit type: LIMit or TRIP. Query state of current limit—no associated command.	0.0 8V OFF 0.25 LIM
OUTPut[1] [:STATe] :BANDwidth <name> :IMPedance <NRf>	OUTPut [1] subsystem for Channel #1 (battery channel): Turn the power supply output ON or OFF. Specifies output bandwidth (HIGH or LOW). Specifies output impedance (0–1Ω in 10mΩ steps).	OFF LOW* 0
OUTPut2 [:STATe] :BANDwidth <name>	OUTPut2 subsystem for Channel #2 (charger channel): Turn the power supply output ON or OFF. Specifies output bandwidth (HIGH or LOW).	OFF HIGH
:BOTHOUTON :BOTHOUTOFF	Turns both power supply channels ON. Turns both power supply channels OFF.	

*Default is HIGH for firmware version B02 and lower (does not apply to Model 2306-PJ).

NOTE Refer to the Programming syntax paragraph of Section 6 for a description of parameters (e.g., , <NRf>, etc.).

Command notes (outputting voltage and current)

SENSe[1]:CURRent:RANGe <n> Applies to battery channel (#1)

SENSe2:CURRent:RANGe <n> Applies to charger channel (#2)

After specifying a current value, the instrument will go to the most sensitive range to accommodate that reading. For example, if you are expecting a maximum current reading of 750mA, you can let <n> = 0.75 (or 750e-3) to select the 5A range. Using the :RANGe command to manually select a current range disables auto range. Another way to select a range is to use the MINimum, MAXimum, and DEFault parameters as follows:

SENS:CURR:RANG MIN Select the low current range (5mA) for battery channel (#1).

SENS2:CURR:RANG MAX Select the high current range (5A) for charger channel (#2).

SENS2:CURR:RANG DEF Select the default current range for charger channel (#2).

The response for :RANGe? query returns the selected range value which is either 5.0000 or 0.0050.

**SENSe[1]:CURRent:RANGe:AUTO ** Applies to battery channel (#1)

**SENSe2:CURRent:RANGe:AUTO ** Applies to charger channel (#2)

This command is coupled to the :RANGe <n> command. When auto range is enabled, the response for :RANGe? query returns the selected range value which is either 5.0000 or 0.0050. If you then disable auto range, the instrument will remain at the last selected range.

[SOURce1]:VOLTage <n> Applies to battery channel (#1)

SOURce2:VOLTage <n> Applies to charger channel (#2)

This command sets voltage amplitude in volts: 0 to 15 (1mV resolution).

[SOURce1]:CURRent <n> Applies to battery channel (#1)

SOURce2:CURRent <n> Applies to charger channel (#2)

- With the 5mA measurement range selected, the maximum current limit is 1A.
- Sending a value that exceeds 1A is rejected, and the following message is displayed briefly:

```
CURRENT LIMIT ON
mA RANGE ≤ 1A
```

[SOURce[1]]:CURRent:STATe?	Applies to battery channel (#1)
SOURce2:CURRent:STATe?	Applies to charger channel (#2)
<ol style="list-style-type: none"> 1. With the LIMit type selected, this command returns a “1” if the power supply is operating as a constant-current source (current limit reached). With the TRIP type selected, a “1” is returned if the output has turned off (tripped) due to current limit being reached. It will clear to “0” when the output is turned back on. 2. The operation event register can be read to determine if the power supply is in current limit and if the output has tripped (turned off) as a result of the current limit condition. See Section 7 for details. 	
OUTput[1]:IMPedance <NRf>	Applies to battery channel (#1)
This battery channel only command may be set from 0–1Ω in 0.01Ω steps. The command can be used with the output ON or OFF.	
OUTput[1]:BANDwidth <name>	Applies to battery channel (#1)
OUTput2:BANDwidth <name>	Applies to charger channel (#2)
This command specifies HIGH or LOW bandwidth only when the output state is ON and the current range is set to 5A. When the output is OFF or the current range is 5mA for the Model 2306 (or 500mA for the battery channel on 2306-PJ), the bandwidth is LOW. This is summarized in Table 2-2.	
BOTHOUTON	Turns both channels ON
BOUTHOUTOFF	Turns both channels OFF

NOTE *These commands are available starting in firmware release version B02. Use the Model 2306 REVISION NUMBER menu item (located on the main menu) to display the firmware revision for the microcontroller and the display.*

When sending either command, make note that the command is applied to channel 1 (battery channel) first and then to channel 2 (charger channel). This allows both channels’ output state to be controlled with a single bus command while preventing the outputs from being turned ON or OFF simultaneously. No short form exists for this command.

Reading back V and I

Actual V and I display mode

Measured output voltages and currents are displayed with the actual V and I display mode selected. This display mode is selected as follows:

NOTE *To display measured readings if the instrument is in the settings mode, press the SET key until the blinking stops (the measured readings can then be displayed). To determine if the instrument is in the settings mode, check for a blinking cursor in a digit of the voltage or current field (if present, the instrument is in the setting mode).*

1. Press the DISPLAY key to access the display menu. DISPLAY TYPE #1 (battery channel active) or DISPLAY TYPE #2 (charger channel active) will appear on the top line of the display. Use ◀ or ▶ keys to toggle the active channel.
2. Press the ▲ or ▼ keys until “ACTUAL V AND I” is displayed.
3. Press ENTER. Voltage readings are located on the top line of the display, and current readings are located on the bottom line.

NOTE For details on display modes, see “Display modes” in Section 1.

Measurement configuration

CURRENT RANGE #1/#2, INTEGRATION RATE #1/#2, and the AVER READINGS #1/#2 can be checked or changed from the menu (which is accessed by pressing the MENU key). The “#1” (battery channel active) or “#2” (charger channel active) will appear on the top line of the display. (Use ◀ or ▶ keys to toggle the active channel.)

NOTE Table 1-3 shows the menu structure. Rules to navigate the menu follow the table.

Current range

Current range is linked with current limit. Therefore, as a general rule, the user selects the current range before setting the current limit. The current range can be changed at any time, but selecting the lower range may change the current limit setting. See “Outputting voltage and current” on page 2-5 for details on current range and current limit.

NPLC rate

The integration (reading) rate of the instrument is specified as a parameter based on the number of power-line cycles (NPLC), where 1 PLC for 60Hz line frequency is 16.67msec (1/60). In general, the fastest integration time (0.01 PLC) results in increased reading noise. The slowest integration time (10 PLC) provides the best common-mode and normal-mode rejection. In-between settings are a compromise between speed and noise.

The NPLC RATE #1/#2 item of the menu is also used to set the reading rate for DVM measurements. Note that it is not used to set the integration rate for pulse current and long integration measurements. These measurements are covered in Sections 3 and 4, respectively.

Average readings

The average reading count (1 to 10) specifies the number of measurement conversions to average for each reading. For example, with a reading count of 5, each displayed reading will be the average of five measurement conversions.

The AVER READINGS #1/#2 menu items are also used to set the average reading count for DVM measurements. Note that it is not used to set the average reading count for pulse current (see Section 3) or long integration measurements (see Section 4).

SCPI programming — measure V and I, and DVM input

The commands to measure output voltage and current, and the DVM input are summarized in Table 2-4 (a listing following the table contains specific command notes). The “Programming examples” at the end of this section demonstrates how to use these commands.

Table 2-4
SCPI commands — measure V and I, and DVM input

Commands	Description	Default
SENSE[1] :FUNCTION <name> :NPLCycles <n> :AVERAge <NRf>	SENSE[1] subsystem for Channel #1 (battery channel): Select readback function: “VOLTage”, “CURRent”, or “DVMeter”. Set integration rate (in line cycles) for voltage, current, and DVM measurements: 0.01 to 10. Specify the average count for voltage, current, and DVM measurements: 1 to 10.	VOLT 1.0 1
SENSE2 :FUNCTION <name> :NPLCycles <n> :AVERAge <NRf>	SENSE2 subsystem for Channel #2 (charger channel): Select readback function: “VOLTage”, “CURRent”, or “DVMeter”. Set integration rate (in line cycles) for voltage, current, and DVM measurements: 0.01 to 10. Specify the average count for voltage, current, and DVM measurements: 1 to 10.	VOLT 1.0 1
READ[1]? READ[1]:ARRay? READ2? READ2:ARRay?	Trigger and return one reading for Channel #1 (battery channel) ¹ . Trigger an array of readings and return them for Channel #1 (battery channel) ¹ . Trigger and return one reading for Channel #2 (charger channel) ¹ . Trigger an array of readings and return them for Channel #2 (charger channel) ¹ .	

¹This command applies to the currently selected function.

NOTE Refer to the Programming syntax paragraph of Section 6 for a description of parameters (e.g., , <NRf>, etc.).

Command notes (measure V and I, and DVM input)

SENSe[1]:FUNCTION <name> Applies to battery channel (#1)

SENSe2:FUNCTION <name> Applies to charger channel (#2)

1. The parameter name can instead be enclosed in single quotes (e.g., 'CURRent').
2. With "DVMeter" selected, the instrument measures the voltage applied to the input of the digital voltmeter (DVM).
3. The "PCURrent" and "LINTegration" parameters for :FUNCTION (which are not listed in Table 2-4) select the pulse current and long integration measurement modes. These measurement modes are covered in Sections 3 and 4, respectively.

SENSe[1]:AVERAge <NRf> Applies to battery channel (#1)

SENSe2:AVERAge <NRf> Applies to charger channel (#2)

1. When requesting a single reading (FETCh?, READ?, or MEASure?), average count specifies the number of measurement conversions to average for the reading. For example, with the average count set to 10, READ? will trigger 10 measurement conversions and return (and display) the average of those 10 conversions for the battery channel. When requesting an array of readings (FETCh:ARRAy?, READ:ARRAy? or MEASure:ARRAy?), average count specifies the number of measurements to place in an array. For example, with the average count set to 10, READ:ARRAy? will trigger and return 10 battery channel readings (charger channel command similar).
2. Signal oriented measurement commands (e.g., READ?) are covered in Section 9.

Independent voltage measurements (DVM)

The power supply has an independent digital voltmeter (DVM) that can measure up to +30VDC and down to -5VDC. Connections for the DVM are shown in Figure 2-1.

DVM input display mode

The DVM input display mode must be selected in order to measure voltage applied to DVM input of the power supply. This display mode is selected as follows:

NOTE *To display measured readings if the instrument is in the settings mode, press the SET key until the blinking stops (the measured readings can then be displayed). To determine if the instrument is in the settings mode, check for a blinking cursor in a digit of the voltage or current field (if present, the instrument is in the setting mode).*

1. Press the DISPLAY key to access the display menu. DISPLAY TYPE #1 (battery channel active) or DISPLAY TYPE #2 (charger channel active) will appear on the top line of the display. Use ◀ or ▶ keys to toggle the active channel.
2. Press the ▲ or ▼ key until "DVM INPUT" is displayed.
3. Press ENTER.

NOTE *For details on display modes, see "Display modes" in Section 1.*

Measurement configuration

The NPLC RATE #1/#2 and AVER READINGS #1/#2 for DVM measurements can be checked or changed from the menu (which is accessed by pressing the MENU key). The “#1” (battery channel active) or “#2” (charger channel active) will appear on the top line of the display. (Use ◀ or ▶ keys to toggle the active channel.)

NOTE Table 1-3 shows the menu structure. Rules to navigate the menu follow the tables.

These two measurement configuration menu items are the same ones used for actual V and I measurements. See “Measurement configuration” on page 2-15 for details on NPLC rate and average readings.

SCPI programming — DVM

The commands to perform actual V and I measurements are also used to perform DVM measurements. These commands are documented in Table 2-3.

The “DVM measurements” programming example at the end of this section demonstrates how to use these commands to measure the DVM input.

Sink operation

Sink operation allows the power supply to be used as a constant current load. To function as a constant current load, the power supply must be in compliance (current limit). When operating as a sink, the power supply is dissipating power rather than sourcing it. Figure 2-3 shows an example of how the power supply can be made to operate as a sink. An external source, such as a battery charger circuit, whose voltage is higher than the programmed power supply voltage, is connected as shown. If the supply is operated in remote sense and $V_{\text{Charger}} > V_{\text{Supply}} + I_{\text{sink}}R_{\text{cable}}$, current I_{sink} flows into the positive (+) terminal of the power supply. Current readback is negative.

CAUTION Exceeding current sink capacity (0–5V: 3A max. 5V–15V: Derate 0.2A per volt above 5V) could cause damage to the power supply that is not covered by the warranty.

Figure 2-3
Sink operation

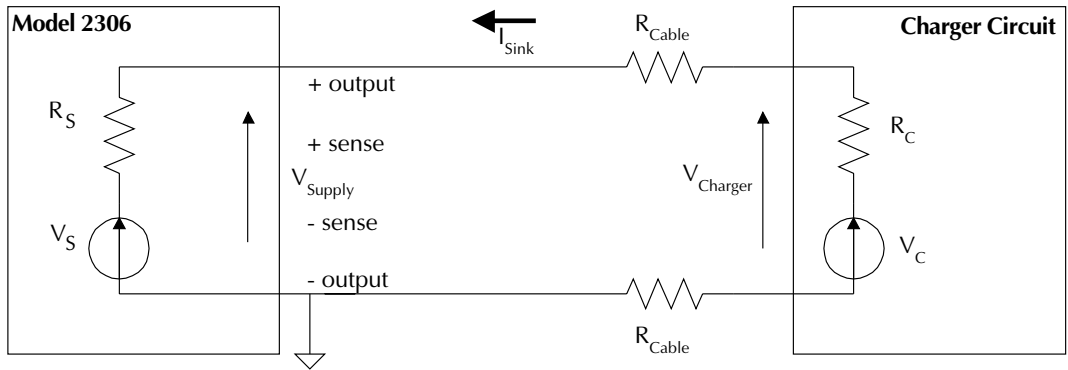

However, in this configuration current compliance may not be reached and current measurements may be unstable if $I_{\text{sink}}R_{\text{cable}}$ is large. Figure 2-4 shows a preferred method for measuring the current output of the charger circuit at a rated output voltage with the power supply operating in local sense mode. Set the supply output voltage to 0.00V and enter the desired test (compliance) current, I_{test} . Select R_{test} so that V_{charger} , the desired test voltage, is the product of I_{test} and R_{test} .

Figure 2-4
Preferred method

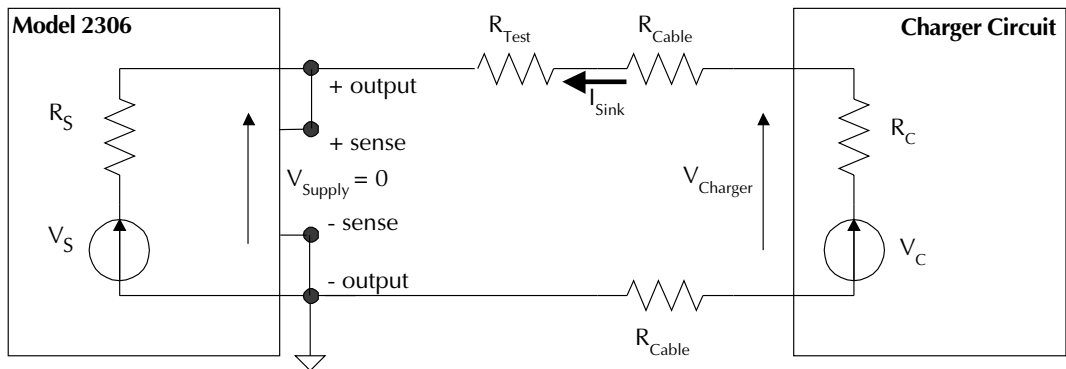

NOTE Figure 2-4 shows the preferred method for measuring current output of the charger circuit at a rated output voltage with the power supply operating in local sense mode.

Unless high speed transient performance is absolutely required when operating as a sink, the LOW bandwidth output mode provides superior results with a constant current or voltage load such as a battery charger.

Programming examples

Outputting and reading back V and I

The following command sequences demonstrate how to output voltage and current, and read back (measure) the actual voltage and current:

Battery channel (#1)

```
DISP:CHAN 1           ` Select battery channel as active one.
VOLT 5               ` Set output voltage to 5V.
SENS:CURR:RANG:AUTO ON ` Enable auto range for current.
CURR 750e-3         ` Set current limit to 750mA.
CURR:TYPE TRIP      ` Select trip mode for current limit.
SENS:FUNC 'VOLT'    ` Select the voltage measurement function.
SENS:NPLC 2         ` Set integration rate to 2 PLC.
SENS:AVER 5         ` Set average reading count to 5.
OUTP ON            ` Turn on the power supply output.
READ?              ` Trigger 5 voltage measurement conversions
                   and return the average of those 5 conversions.
                   The average reading is displayed on the front
                   panel.

SENS:FUNC 'CURR'    ` Select current measurement function.
READ?              ` Trigger 5 current measurement conversions and
                   return the average of those 5 conversions.
                   The average of the 5 readings is displayed on
                   the front panel.
```

Charger channel (#2)

```
DISP:CHAN 2           ` Select charger channel as active one.
SOUR2:VOLT 5         ` Set output voltage to 5V.
SENS2:CURR:RANG:AUTO ON ` Enable auto range for current.
SOUR2:CURR 750e-3    ` Set current limit to 750mA.
SOUR2:CURR:TYPE LIM  ` Select LIM mode for current limit.
SENS2:FUNC 'VOLT'    ` Select the voltage measurement function.
SENS2:NPLC 4         ` Set integration rate to 4 PLC.
SENS2:AVER 4         ` Set average reading count to 4.
OUTP2 ON            ` Turn on the power supply output.
READ2?             ` Trigger 4 voltage measurement conversions
                   and return the average of those 4 conversions.

SENS2:FUNC 'CURR'    ` Select current measurement function.
READ2:ARR?          ` Trigger 4 current measurement conversions and
                   return all 4 conversions. The average of the
                   4 readings is displayed on the front panel.
```

DVM measurements

The following command sequence demonstrates how to measure voltage applied to the DVM input of the power supply:

Battery channel (#1)

DISP:CHAN 1	` Set active channel - battery.
SENS:FUNC `DVM`	` Select the DVM Input function.
SENS:NPLC 6	` Set integration rate to 6 PLC.
SENS:AVER 10	` Set average reading count to 10.
READ:ARR?	` Trigger and return 10 readings. The average of the 10 readings is displayed on the front panel.

Charger channel (#2)

DISP:CHAN 2	` Set active channel - charger.
SENS2:FUNC `DVM`	` Select the DVM Input function.
SENS2:NPLC 3	` Set integration rate to 3 PLC.
SENS2:AVER 8	` Set average reading count to 8.
READ2:ARR?	` Trigger and return 8 readings. The average of the 8 readings is displayed on the front panel.

Pulse Current Measurements

- **Overview** — Provides an overview of the pulse current measurement process.
- **Measurement configuration** — Explains how to configure the instrument for pulse current measurements.
- **Pulse current measurement procedure** — Provides the step-by-step procedure to perform pulse current measurements from the front panel.
- **SCPI programming — pulse current measurements** — Documents the commands used to program the instrument for pulse current measurements, and covers pulse current digitization (which can only be performed over the GPIB).
- **Pulse current digitization** — Explains how to digitize a current waveform.
- **Pulse current step method** — Explains use of the pulse current step method to perform a series of different trigger level measurements on the same trigger level range.
- **Programming examples** — Seven programming examples are provided; two for pulse current measurements, two for pulse current digitization, and three for pulse current step method.

NOTES *This manual covers Keithley Models 2302, 2302-PJ, 2306, and 2306-PJ simulators (power supplies). Since the Model 2302 and 2302-PJ are single channel battery simulators, functions related to the second channel (i.e., the charger channel) are not available for the Model 2302 and 2302-PJ. Therefore:*

- *battery and charger channel features contained in this manual apply for the Model 2306 and 2306-PJ*
- *only battery channel features contained in this manual apply for the Model 2302 and 2302-PJ*

Refer to Appendix F for specific Model 2302 and 2302-PJ information.

Information contained in this section applies to all power supply channels (unless otherwise noted). In this manual, channel 1 refers to the battery channel while channel 2 refers to the charger channel (2306 and 2306-PJ feature only).

Overview

The power supply can perform current measurements for dynamic loads on either battery channel (#1) or charger channel (#2). The built-in measurements include:

- Peak measured current — measures the peak (high) current of the pulse train.
- Idle measured current — measures the idle (low) current of the pulse train.
- Average transmit current — measures the average current of the pulse train.

The high, low, and average measurements of a pulse are illustrated in Figure 3-1. The high measurement is triggered on the rising edge of the pulse, and an integration is performed for the time specified for the high measurement. The falling edge of the pulse triggers the low measurement, and an integration is performed for the time specified for the low measurement. An average measurement is triggered on the rising edge, and the integration is specified by the average measurement time setting. Each pulse current measurement reading will trigger on the respective edge.

NOTE Two other measurements of pulse currents are available over the bus. See “Pulse current digitization” on page 3-30 and “Pulse current STEP method (battery channel only)” on page 3-31 for details.

NOTE Available current measurement range(s):

- Model 2306: 5A
- Model 2306-PJ: 5A, 500mA

Figure 3-1
Pulse current measurement

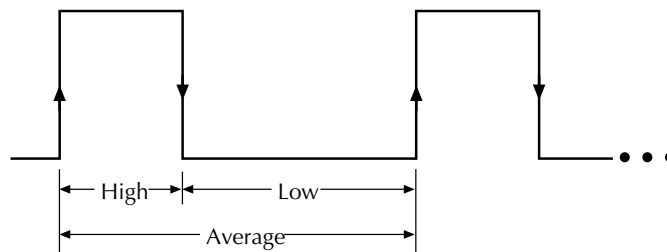

↑ High and average measurements triggered on leading edge of pulse

↓ Low measurement triggered on falling edge of pulse

Trigger level

For the Model 2306 and 2306-PJ on the 5A current range, to avoid false pulse detection, you can use a trigger level of up to 5A. All pulses, noise, or other transients that are less than the set trigger level will be ignored. The charger channel has only one trigger level range setting from 0 to 5A. The battery channel has three trigger level range settings: 5A, 1A, or 100mA trigger level ranges. For 5A, the level may be set from 0 to 5A. For 1A, the trigger level may be set from 0 to 1A. Likewise, the level may be set from 0 to 100mA for the 100mA trigger level range. These ranges affect trigger level resolution and not the current range selection since pulse current readings are always performed on 5A current range. The trigger level range option on the battery channel allows the user to set a trigger level with greater resolution.

On the Model 2306-PJ, you can also measure the pulse current on the 500mA current range. Therefore, in addition to the three range settings for the 5A current range, the 2306-PJ has three additional trigger level range settings for the 500mA current range: 0-500mA, 0-100mA, and 0-10mA. These ranges also affect trigger level resolution for the 500mA current range.

Trigger level range

For the Model 2306 and 2306-PJ on the 5A current range, this setting affects the pulse current trigger level and has no effect on the current range setting since the pulse current measurement is always performed on the 5A current range. Three settings (battery channel only) are available: 5A, 1A, or 100mA. Use the range that provides adequate trigger level resolution (a 100mA range provides a greater available resolution for trigger level than does the 1A range).

The Model 2306-PJ operates in the same fashion with respect to the 500mA current range. When using the Model 2306-PJ's 500mA current range, the three trigger level range settings are: 500mA (0.5mA step), 100mA (0.1mA step), and 10mA (0.1mA step).

Trigger delay

The high, low, or average integration times can either be manually or automatically set. When a pulse is detected, there is a 15µsec code execution delay (internal trigger delay — see Figure 3-2) before the integration time begins. An additional user trigger delay can be set to allow the leading edge pulse overshoot to settle. Regardless of the user trigger delay setting, the internal trigger delay is always present.

Figure 3-2
Trigger delay for high pulse current measurement

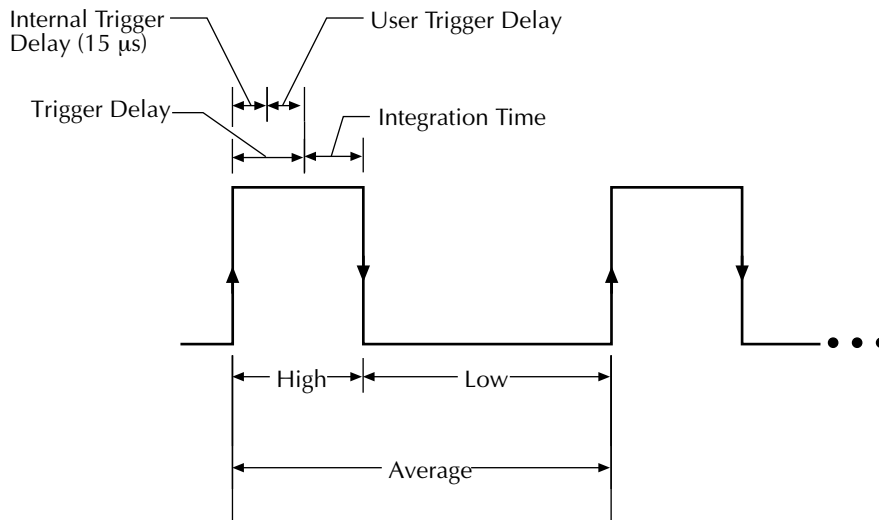

High = integration time specified for high measurement time + *Trigger Delay*

Low = integration time specified for low measurement time + *Trigger Delay*

Average = integration time specified for average measurement time + *Trigger Delay*

Trigger Delay = Internal trigger delay (15 µs) + User trigger delay

The integration time will not start until the trigger delay period expires after detecting the pulse. For accurate readings, make sure that the trigger delay (user and internal) plus the integration time does not exceed the time for the overall measurement. Refer to Figure 3-2 for an illustration containing the trigger delay relationships for a high pulse current measurement.

Integration times

The three integration time periods for pulse measurements can be set automatically or manually by the user. When the pulse auto time operation is performed, the instrument measures the high and low periods of the detected pulse and sets appropriate integration times. The pulse average time is set to the sum of the measured high and low times. The three integration times apply for all subsequent pulse measurements until another pulse auto time is performed or the times are changed manually. The pulse auto time feature can detect pulses in the 80 μ sec to 833msec range. Auto time (when used) accounts for the internal trigger delay (15 μ sec).

You can manually set the pulse high time, pulse low time, and pulse average time. However, you must make sure the integration time covers the portion of the pulse of interest. For example, if the pulse is high for 600 μ sec, the high integration time must be \leq 600 μ sec. If not, you will integrate a low portion of the pulse, and the high pulse measurement will be compromised. Be sure to factor in the trigger delay (both internal plus user) when determining integration times (see Figure 3-2). When manually set using the front panel keys, the values are changed in increments of 33.3333 μ sec. This ensures that an integral value of 33.3333 μ sec will be selected.

NOTE Auto time does not account for user trigger delay — if using auto time, make sure the user trigger delay is appropriately set for the desired overall measurement time.

After auto time acquires a time value (auto time), the auto time is adjusted for the internal trigger delay of 15 μ sec (auto internal time). The auto internal time is then adjusted to be an integral time value of 33.3333 μ sec (auto integral time). For example:

auto time value = 28.053msec

auto internal time = 28.053ms - 0.015msec = 28.038ms

auto integral time = 28.033ms (response returned when time setting is queried)

When a pulse time is set via the bus, the time is assumed to be an auto internal time (i.e., the value is assumed to be adjusted for the internal delay value). This value is then adjusted to the applicable integral value. For example:

manual time value = 5.040msec

integral time = 5.033ms (response returned when time setting is queried)

Average readings count

NOTE The menu item AVER READINGS #1/#2 applies to average readings for DVM, I and V where AVERAGE READINGS under PULSE CURRENT #1/#2 menu item applies to pulse current measurements.

The average readings count specifies how many measurements (integrations) are performed and averaged for each displayed reading. For example, assume that the pulse average readings count is 10 and you are measuring PULSE HIGH. Each displayed reading will reflect the average of 10 peak pulse measurements.

Measurement configuration

NOTES Current range is selected from the CURRENT RANGE #1/#2 item of the menu. Integration times, average readings count, trigger delay, trigger level range, and trigger level are set from the PULSE CURRENT item of the menu. Details on integration rate, average readings count, trigger delay, trigger level range, and trigger level are provided in the "Overview" starting on page 3-2.

Table 1-3 shows the menu structure. Rules to navigate the menu follow the table.

The menu item AVER READINGS #1/#2 applies to average readings for DVM, I, and V, where the AVERAGE READINGS under PULSE CURRENT #1/#2 applies to pulse current measurement.

Current range

For pulse current measurements, the AUTO range selection is functionally a no-op (no operation). The instrument will not auto range with the pulse current measurement function selected. Pulse current measurements are always performed on the 5A range. Therefore, selecting pulse current with the 5mA range active will cause the supply to first switch to the 5A range regardless of the current range setting (5mA or AUTO).

Current range is linked to current limit. Therefore, as a general rule, the user selects the current range before setting the current limit. See "Outputting voltage and current" (in Section 2) for details on current range and current limit. Current range is selected from CURRENT RANGE #1/#2 item of the menu (CURRENT RANGE #1 refers to the battery channel while CURRENT RANGE #2 refers to the charger channel).

NOTE To get better trigger level resolution, make sure the trigger level range (battery channel only) is set appropriately for the expected measurement.

Integration times

Use the following items of the PULSE CURRENT #1/#2 menu item to set integration times:

NOTE Set PULSE CURRENT integration times in the range of 33.3 μ sec to 833ms (833333 μ sec) in 33.3333 μ sec steps.

- **HIGH TIME** — Use to set the integration period (in μ sec) for high pulse-current measurements. Make sure to account for the internal (15 μ sec) and user trigger delay.
- **LOW TIME** — Use to set the integration period (in μ sec) for low pulse-current measurements. Make sure to account for the internal (15 μ sec) and user trigger delay.
- **AVERAGE TIME** — Use to set the integration period (in μ sec) for average pulse-current measurements. Make sure to account for the internal (15 μ sec) and user trigger delay.
- **AUTO TIME** — Use to automatically set the integration times for high, low, and average pulse-current measurements. These times are based on detecting the pulse and remain until another auto time is performed or the times are manually changed. Auto time accounts for the internal (15 μ sec) delay but not the user trigger delay.
- **PULSE TIMEOUT** — Use to set the variable pulse current timeout feature for pulse current measurements. The default value is 1.000 second (incremented in 1ms steps). Refer to "Using FAST, SEARch, and DETect" for detailed usage information on properly setting this TimeOUT variable.

Average readings count

Use the AVERAGE READINGS item of the PULSE CURRENT #1/#2 menu item to set the average readings count. This count specifies the number of measurements (integrations) to average for each reading. For example, with measurement count set to 10, each displayed reading will reflect the average of 10 pulse current measurements. Each measurement needs to start after detecting the respective edge for triggering.

NOTE Set AVERAGE READINGS count in the range of 1 to 100.

Trigger delay, trigger level range, and trigger level

Use the following items of the PULSE CURRENT menu item to set trigger delay, trigger level range, and trigger level:

- **TRIGGER DELAY** — Use to specify additional user trigger delay (0 to 100msec in 10 μ sec steps). See "Trigger delay" on page 3-4 for details. This user trigger delay is in addition to the internal trigger delay of 15 μ sec.
- **TRG LEV mA Range** — Model 2306-PJ battery channel only setting. Use to specify the trigger level range resolution. Possible ranges are:
Model 2306-PJ (500mA current range only)

500mA FULL SCALE	(0–500mA)
100mA FULL SCALE	(0–100mA)
10mA FULL SCALE	(0–10mA)

- **TRG LEVEL mA** — Model 2306-PJ — Use to specify the trigger level for the 500mA current range (battery channel only). Pulses less than the specified level are not detected.

Battery Channel (#1): Model 2306-PJ — On the 500mA current range, the trigger level can be set for 500mA, 100mA, or 10mA range:

500mA range 0-500mA in 0.5mA steps.

100mA range 0-100mA in 0.1mA steps.

10mA range 0-10mA in 0.1mA steps.

Trigger hysteresis is built into the hardware. For the 500mA range, trigger hysteresis is approximately 1mA. For the 100mA range, trigger hysteresis is approximately 0.2mA. For the 10mA range, trigger hysteresis is approximately 0.02mA. If a pulse does not exceed the appropriate hysteresis level, trigger detection will not occur. The three trigger level ranges for the battery channel (#1) are displayed as follows:

```
500mA Range: PCUR TLEV mA #1
              mA ( 500 ) 0.0000A
```

```
100mA Range: PCUR TLEV mA #1
              mA ( 100 ) 0.0000A
```

```
10mA Range:  PCUR TLEV mA #1
              mA ( 10 ) 0.0000A
```

To change the range for the trigger level setting, place the blinking cursor on the “A” at the far right end of line two of the display, and press the ▲ or ▼ key. After keying in the trigger level (in amps), press ENTER to update the displayed range for that trigger level setting only.

- **TRIG LEVEL RANGE** — Battery channel (#1) setting only. Use to specify the trigger level range resolution. Possible ranges are:

Model 2306 and 2306-PJ (5A current range)

5A FULL SCALE (0-5A)

1A FULL SCALE (0-1A)

100mA FULL SCALE (0-100mA)

- **TRIGGER LEVEL** — Use to set the trigger level. Pulses less than the specified level are not detected.

Battery Channel (#1) — On the 5A current range, the Model 2306 and 2306-PJ trigger level can be set for either the 5A, 1A, or 100mA range.

Trigger level

5A range 0-5A in 5mA steps.

1A range 0-1A in 1mA steps.

100mA range 0-100mA in 0.1mA steps.

Trigger hysteresis is built into the hardware. For the 5A range, trigger hysteresis is approximately 10mA. For the 1A range, trigger hysteresis is approximately 2mA. For the 100mA range, trigger hysteresis is approximately 0.2mA. If a pulse does not exceed the appropriate hysteresis level, trigger detection will not occur.

The three trigger level ranges for the 5A current range on the battery channel (#1) are displayed as follows:

```
5A Range:   PCUR TRIG LEVEL #1
            A (5.0)   0.000A
1A Range:   PCUR TRIG LEVEL #1
            A (1.0)   0.000A
100mA Range: PCUR TRIG LEVEL #1
            mA (100)  0.0000A
```

To change the range for the trigger level setting, place the blinking cursor on the “A” at the far right end of line two of the display, and press the ▲ or ▼ key. After keying in the trigger level (in amps), press ENTER to update the displayed range for that trigger level setting only.

Charger Channel (#2) — Set the trigger level from 0 to 5A in 5mA steps. However, there is approximately 10mA of trigger hysteresis built into the hardware. Therefore, if a pulse does not exceed this level, trigger detection will not occur.

Pulse current display mode

Pulse current measurements are displayed with the pulse current display mode selected. This display mode is selected as follows:

NOTE *To display measured readings if the instrument is in the settings mode, press the SET key until the blinking stops (the measured readings can then be displayed). To determine if the instrument is in the settings mode, check for a blinking cursor in a digit of the voltage or current field (if present, the instrument is in the setting mode).*

1. Press the DISPLAY key to access the display menu.
2. If the desired active channel is not selected, use the ◀ and ▶ keys to toggle the active channel. The top line of the display will show which channel is active as either DISPLAY TYPE #1 or DISPLAY TYPE #2.
3. Press the ▲ or ▼ key until “PULSE CURRENT” is displayed and press ENTER.
4. Use the ▲ or ▼ key to display the desired pulse measurement; PULSE HI, PULSE LO, or PULSE AVG.

NOTE *For details on display modes, see “Display modes” in Section 1.*

Pulse current measurement procedure

The following steps summarize the procedure to perform pulse measurements:

1. Press the MENU key to access the menu.
2. Select PULSE CURRENT #1 or #2 by scrolling through the primary menu items (use the ▲ and ▼ keys to scroll).
3. For the battery channel (#1), select the desired trigger level range (5A, 1A, or 100mA) from the TRIG LEVEL RANGE item of the PULSE CURRENT #1 menu. Pulse measurements for both channels are automatically performed on the 5A current range.
4. From the PULSE CURRENT #1/#2 item of the menu, set the trigger level, trigger delay (optional), integration times, and average readings count (optional). (See NOTE.)
5. As explained in Section 2, set the output voltage and current limit, and press OPERATE.
6. Press the DISPLAY key and select the PULSE CURRENT display type.
7. Use the ▲ or ▼ key to display the desired pulse measurement: PULSE HIGH, PULSE LOW, or PULSE AVG.

NOTES For the charger channel (#2), the trigger level range is automatically set to the 0–5A range (non-configurable).

Setting the trigger level with the output off will cause the pulse timeout message to appear. However, the trigger level will be set.

No pulses detected

If no pulses are detected, current will not be measured (i.e. ----A) and the “NO PULSE” message will be displayed. The “NO PULSE” message is displayed with dashes or the last valid pulse reading. Dashes are shown if the pulse-current measurement settings are not appropriate for detecting pulses. The last valid pulse is shown if the pulse disappears while taking readings and no change in pulse settings was made.

Pulses are not detected with the output OFF. With the output ON, pulses will not be detected if the trigger level is too low or too high. Perform the following procedure to find an appropriate trigger level. Make sure the voltage and current settings are appropriate for detecting pulses.

Determining correct trigger level (pulse current)

NOTE *If possible, always use an oscilloscope to determine the timing and transient characteristics of a DUT. The waveform information is very useful in setting up the 2306, reducing setup time and achieving maximum performance and productivity. The voltage and current characteristics of the DUT can be determined with a 2-channel Oscilloscope with differential inputs, a 0.1Ω resistor used as a current sense resistor, and a voltage probe at the DUT as shown in Figure 3-3. Differential oscilloscope inputs are required to prevent grounding the supply output leads.*

Figure 3-3
Determining voltage and current characteristics

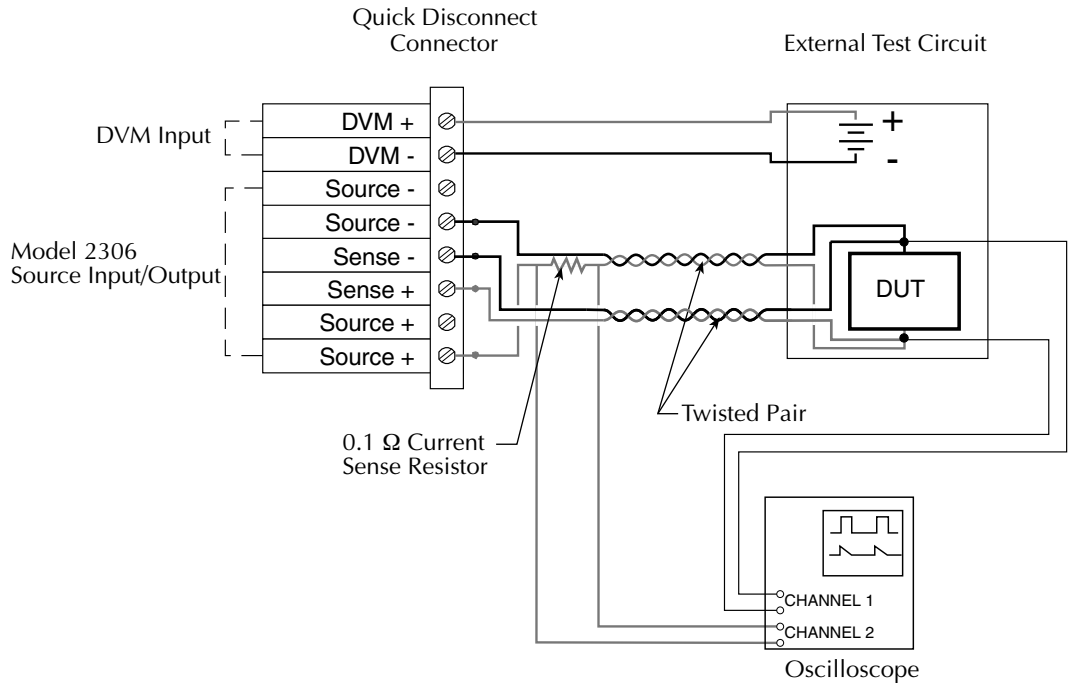

Procedure

1. As explained in Section 2, set the output voltage and current limit.
2. Press OPERATE.
3. Select the pulse current display type. If the trigger level is too low or too high, the “NO PULSE” message will be displayed.
4. Go into the menu, select PULSE CURRENT #1/#2, and then TRIGGER LEVEL.
5. Change the PCUR TRIG LEV #1/#2 and press ENTER. If the trigger level is still too low or too high, the “TRIG NOT DETECTED” message will be displayed briefly. Note that it may take a few seconds for the message to appear. (See “TRIG NOT DETECTED message” on page 3-12 for more information.)
6. If the message appeared, repeat step 5 until a valid trigger level is found.
7. Use the MENU key to back out of the menu structure and display pulse current measurements.

TRIG NOT DETECTED message

The TRIG NOT DETECTED message is displayed when specific TLEV settings coupled with specific TLEV ranges have been set and a trigger has not been detected. Refer to Table 3-1 for the message preconditions.

Table 3-1
TRIG NOT DETECTED message

TLEV setting	TLEV range	TRIG NOT DETECTED Message displayed?
90mA for 100mA range	1A	No (not checked because TLEV setting does not match TLEV range)
90mA for 100mA range	5A	No (not checked because TLEV setting does not match TLEV range)
0.75A for 1A range	1A	May appear ¹
0.1A for 5A range	5A	May appear ¹
3.0A for 5A range	5A	May appear ¹
1.1A for 5A range	100mA	No (not checked because TLEV setting of 5A does not match TLEV range of 100mA)
1.1A for 5A range	1A	No (not checked because TLEV setting of 5A does not match TLEV range of 1A)

¹May appear depends on OUTPUT:

- If OFF, the message will appear.
- If ON, display of the message will depend on the trigger level setting. If trigger level setting > expected low measurement and also trigger level setting < the expected high measurement, the message will not appear.

For example, if the expected pulse high is 2.2A and the expected pulse low is 0.5A, the output is on, and the TLEV range is 5A, notice the following results:

Setting 0.3A TRIG NOT DETECTED is displayed (setting too low).

Setting 3.0A TRIG NOT DETECTED is displayed (setting too high).

Setting 1.1A The message will not display (setting correct).

See steps 1–3 of the “Pulse current measurement procedure” on page 3-10 for information on setting the trigger level range. For the charger channel #2, the trigger level range setting is not user selectable.

NOTE *Setting the trigger level and/or the trigger range may cause “PULSE CURR TRIG NOT DETECTED” to appear.*

SCPI programming — pulse current measurements

The commands for pulse current measurements are summarized in Table 3-2 (a listing following the table contains specific command notes). “Programming examples” on page 3-28 demonstrate how to use these commands.

Table 3-2
SCPI commands — pulse current measurements

Command	Description	Default
SENSE[1]	SENSE subsystem for Channel #1 (battery channel):	
:FUNCTION “PCURrent”	Select pulse current measurement function.	VOLT
:PCURrent	Pulse current configuration:	
:AVERAge <NRf>	Specify average count: 1–100 (pulse current measurements) or 1–5000 (pulse current digitization).	1
:MODE <name>	Select measurement mode; HIGH, LOW or AVERAge.	HIGH
:TIME	Set integration times:	
:AUTO	Integration times set automatically.	
:HIGH <NRf>	Specify integration time (in sec) for high pulse measurements; 33.33e-6 to 0.8333.	3.333e-5
:LOW <NRf>	Specify integration time (in sec) for low pulse measurements; 33.33e-6 to 0.8333.	3.333e-5
:AVERAge <NRf>	Specify integration time (in sec) for average pulse measurements; 33.33e-6 to 0.8333.	3.333e-5
:SYNChronize	Pulse detection triggering:	
[:STATe]	Send ON to select pulse current measurements or OFF to select pulse current digitization.	ON
:TLEVel	Trigger level:	
[:AMP] <NRf>	Set trigger level (in amps) for 5A range: 0.0–5.0	0.0
:ONE <NRf>	Set trigger level (in amps) for 1A range: 0.0–1.0	0.0
:MILLiamp <NRf>	Set trigger level (in amps) for 100mA range: 0.0–0.1	0.0
:HALFamp <NRf>	Model 2306-PJ only — set trigger level (in amps) for 500mA range: 0-500mA.	0.0
:HUNDred <NRf>	Model 2306-PJ only — set trigger level (in amps) for 100mA range: 0-100mA.	0.0
:TEN <NRf>	Model 2306-PJ only — set trigger level (in amps) for 10mA range: 0-10mA.	0.0
:RANGe <NRf>	Model 2306 or 2306-PJ when on 5A current range. Set trigger level range (100mA, 1A, or 5A). The parameter <NRf> sent with this command causes the trigger to be set with the trigger level setting of MILL, ONE, or AMP. Queries receive responses of 0.1, 1.0, or 5.0 accordingly. In other words, if a value of 2.0A is sent with the command, a value of 5A will be returned as a response to a query.	5A

Table 3-2
SCPI commands — pulse current measurements (cont.)

Command	Description	Default
SENSE[1] :PCURrent :SYNChronize :TLEVel :RANGe <NRf> :MILLiamp <NRf>	<p>Model 2306-PJ when on 500mA current range. Set trigger level range (10mA, 100mA, or 500mA). The parameter <NRf> sent with this command causes the trigger to be set with the trigger level setting of HALFamp, HUNDred, or TEN. Queries receive responses of 0.5, 0.1, or 0.01 accordingly. For example, if a value of 75mA is sent with the command, a value of 0.1A will be returned as a response to a query.</p>	
:DELay <NRf>	<p>Specify trigger delay in seconds: 0.0–0.1 (pulse current measurements) or 0.0–5.0 (pulse current digitization).</p>	0.0
:STEP 	<p>Performs a series of measurements (See “Pulse current step method” on page 3-22</p>	OFF
:UP <NRf>	<0-20> (max is for both up and down combined)	1
:DOWN <NRf>	<0-20> (max is for both up and down combined)	1
:TIME <NRf>	33µsec—100msec	200µsec
:TimeOUT <NRf>	TimeOUT (other than the first): 2msec—200msec	2ms
:INITial <NRf>	First TimeOUT step: 10msec—60secs	2sec
:DELay <NRf>	0msec—100msec (in 1µsec steps)	0
:RANGe <NRf>	<p>Model 2306 or 2306-PJ when on 5A current range. Set trigger level range (100mA, 1A, or 5A). The parameter <NRf> sent with this command causes the trigger to be set with the trigger level setting of MILL, ONE, or AMP. Queries receive responses of 0.1, 1.0, or 5.0 accordingly. In other words, if a value of 2.0A is sent with the command, a value of 5A will be returned as a response to a query.</p>	5A
:MILLiamp <NRf>	<p>Model 2306-PJ when on 500mA current range. Set trigger level range (10mA, 100mA, or 500mA). The parameter <NRf> sent with this command causes the trigger to be set with the trigger level setting of HALFamp, HUNDred, or TEN. Queries receive responses of 0.5, 0.1, or 0.01 accordingly. For example, if a value of 75mA is sent with the command, a value of 0.1A will be returned as a response to a query.</p>	
:TLEVx <NRf>	<p>Set trigger level for each TLEV step where <i>x</i> equals 1—20 (0.0—maxA where max is 100mA for 100mA RANGe setting, 1A for 1A RANGe setting, and 5A for 5A RANGe setting).</p>	0.0

Table 3-2
SCPI commands — pulse current measurements (cont.)

Command	Description	Default
SENSe[1] :PCURrent :FAST :SEARch :DETECT :TimeOUT	Enable or disable pulse current fast readings. Enable or disable pulse current search. Enable or disable pulse current detection mode. Specify length of timeout: 5ms -1000ms (1 second) incrementing in 1ms.	OFF ON OFF 1 (sec)
SENSe2 :FUNCTION "PCURrent" :PCURrent :AVERAge <NRf> :MODE <name> :TIME :AUTO :HIGH <NRf> :LOW <NRf> :AVERAge <NRf> :SYNChronize [:STATE] :TLeVel <NRf> :DELAy <NRf> :FAST :SEARch :DETECT :TimeOUT	SENSe subsystem for Channel #2 (charger channel): Select pulse current measurement function. Pulse current configuration: Specify average count: 1 to 100 (pulse current measurements), or 1 to 5000 (pulse current digitization). Select measurement mode; HIGH, LOW or AVERAge. Set integration times: Integration times set automatically. Specify integration time (in sec) for high pulse measurements; 33.33e-6 to 0.8333. Specify integration time (in sec) for low pulse measurements; 33.33e-6 to 0.8333. Specify integration time (in sec) for average pulse measurements; 33.33e-6 to 0.8333. Pulse detection triggering: Send ON to select pulse current measurements or OFF to select pulse current digitization. Set trigger level in amps: 0.0–5.0 Specify trigger delay in seconds: 0.0–0.1 (pulse current measurements) or 0.0–5.0 (pulse current digitization). Enable or disable pulse current fast readings. Enable or disable pulse current search. Enable or disable pulse current detection mode. Specify length of timeout: 5ms -1000ms (1 second) incrementing in 1ms.	VOLT 1 HIGH 3.333e-5 3.333e-5 3.333e-5 ON 0.0 0.0 OFF ON OFF 1 (sec)
READ[1]? READ[1]:ARRAy?	Trigger and return one reading for Channel #1 (battery channel). Trigger an array of readings and return them for Channel #1 (battery channel).	
READ2? READ2:ARRAy?	Trigger and return one reading for Channel #2 (charger channel). Trigger an array of readings and return them for Channel #2 (charger channel).	

NOTE Refer to the Programming syntax paragraph of Section 6 for a description of parameters (e.g., , <NRf>, etc.).

Command notes (pulse current measurements)

SENSe[1]:FUNCTION 'PCURrent' Applies to battery channel (#1)

SENSe2:FUNCTION 'PCURrent' Applies to charger channel (#2)

This parameter name can also be enclosed in single quotes (as shown above).

SENSe[1]:PCURrent:AVERAge <NRf> Applies to battery channel (#1)

SENSe2:PCURrent:AVERAge <NRf> Applies to charger channel (#2)

1. When requesting a single reading (FETCh?, READ?, or MEASure?), average count specifies the number of pulse current measurement conversions to average for the reading. For example, with the average count set to 10, READ? will trigger 10 pulse current measurement conversions and return (and display) the average of those 10 battery channel conversions (charger channel command similar).
2. When requesting an array of readings (FETCh:ARRAy?, READ:ARRAy? or MEASure:ARRAy?), average count specifies the number of pulse current measurements to place in an array. For example, with the average count set to 10, READ:ARRAy? will trigger and return 10 battery channel readings (charger channel command similar).
3. For pulse current digitization, use an array reading command (such as READ:ARRAy?) to return the digitized readings.
4. Signal oriented measurement commands (e.g., READ?) are covered in Section 9.

SENSe[1]:PCURrent:TIME Applies to battery channel (#1)

SENSe2:PCURrent:TIME Applies to charger channel (#2)

When manually setting the pulse HIGH, LOW, and AVERAge time, make sure that:

1. When manually setting the pulse high, low, and average times, make sure that the integration time only covers the portion of the pulse to be measured.
2. Make sure to factor in trigger delays (both the internal plus the user) when determining integration times. Before the integration process begins after pulse detection, the internal trigger delay of 15µsec (for code execution) in addition to any user specified trigger delay must elapse.
3. AUTO time will account for the internal trigger delay (15msec) but not for any user trigger delay (user trigger delay is set using the DELAY command).

**SENSe[1]:PCURrent:SYNChronize ** Applies to battery channel (#1)

**SENSe2:PCURrent:SYNChronize ** Applies to charger channel (#2)

Boolean parameters:

- ON or 1 - Enables trigger synchronization for pulse current measurements. A pulse current reading will not trigger until the specified trigger level is detected and the specified trigger delay (both the internal plus the user delay) period expires.
- OFF or 0 - Disables trigger synchronization and selects pulse current digitization. See “Pulse current digitization” for details on digitizing a current pulse or waveform.

:TLEvel Commands

A valid trigger level for detecting the pulse is needed whether trigger synchronization is ON or OFF (see :SYNChronize commands above).

SENSe[1]:PCURrent:SYNChronize:DElay <NRf>	Applies to battery channel (#1)
SENSe2:PCURrent:SYNChronize:DElay <NRf>	Applies to charger channel (#2)
<ol style="list-style-type: none"> 1. The smallest step size for trigger delay is 10µsec. If you specify a smaller step size, it is adjusted up to the next 10µsec step value (e.g., 43µsec is adjusted up to 50µsec). 2. After pulse detection but before the integration process begins, the internal trigger delay of 15µsec (for code execution) in addition to any user specified trigger delay must elapse. This command is used to set the user trigger delay. 3. Make sure this setting works with the :TIME settings to produce an accurate reading. Although AUTO accounts for internal trigger delay, HIGH, LOW, and AVERAge do not. Note that none of the TIME commands account for the user trigger delay. 	
SENSe[1]: PulseCURrent:FAST 	Applies to battery channel (#1)
SENSe2: PulseCURrent:FAST 	Applies to charger channel (#2)
Refer to "Using FAST, SEARCh, and DETect" for detailed usage information.	
SENSe[1]:PulseCURrent:SEARCh 	Applies to battery channel (#1)
SENSe2: PulseCURrent:SEARCh 	Applies to charger channel (#2)
Refer to "Using FAST, SEARCh, and DETect" for detailed usage information.	
SENSe[1]: PulseCURrent:DETECT 	Applies to battery channel (#1)
SENSe2: PulseCURrent:DETECT 	Applies to charger channel (#2)
Refer to "Using FAST, SEARCh, and DETect" for detailed usage information.	
SENSe[1]:PulseCURrent:TimeOUT <NRf>	Applies to battery channel (#1)
SENSe2: PulseCURrent: TimeOUT <NRf>	Applies to charger channel (#2)
Refer to "Using FAST, SEARCh, and DETect" for detailed usage information on properly setting the TimeOUT variable.	

Using FAST, SEARCh, and DETect

Use FAST, SEARCh, and DETect to control how background readings are taken. A background reading is a measurement taken by the power supply between user triggered readings. The selected function dictates how background readings are taken between user triggered readings.

For pulse current, a background reading involves looking for the pulse and optionally generating a reading for the user. The various settings of SEARCh, FAST, and DETect allow the user to fine tune the function. This enables the function to perform the desired background readings (if any) between user triggered readings. The default settings (FAST:OFF, SEARCh:ON, and DETect:OFF) allow the pulse current background readings to be taken. If no pulse is present, the setting of TimeOUT affects how responsive the supply is to bus commands. If a pulse is present, the search time affects how responsive the supply is to bus commands (refer to Figure 3-4). Table 3-3 contains the available settings for FAST, SEARCh, and DETect commands and a description of the resulting action.

In order to efficiently use FAST, SEARCH, and DETECT for pulse current measurements, the user must know the approximate period of the expected pulse. TOUT (TimeOUT) specifies the timeout length for searching for the pulse (default setting is 1 second). When the TOUT value is reached, NO PULSE is displayed (top line of the front panel display) if default settings for FAST, SEARCH, and DETECT are used. See Table 3-3 for what is shown on the front panel display if the default settings are not used. Set the value for TOUT as follows:

$$TOUT = Search\ Time + Period$$

Search Time = time allowed for detection of a pulse edge

Period = time between consecutive pulse edges

In other words, the timeout value should be set to allow sufficient time for detection of the pulse if the edge is just missed. In Figure 3-4, (P) is the point to start looking for the pulse. Since the rising edge was just missed, (D) will be the first detectable rising edge. If the timeout is less than search time, a pulse trigger time out (due to TOUT) may occur. Therefore, if the period = 0.4 seconds, a good TOUT value would be 0.5 seconds. A similar method for selecting a TOUT value would be to use a value equal to 105% of the expected pulse period.

Figure 3-4
PCURent and SEARCh time for pulse high measurement

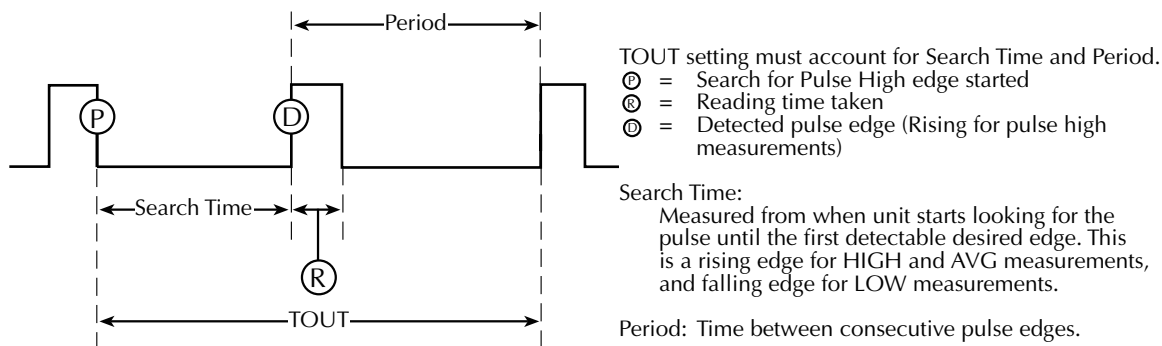

- NOTES**
- If a pulse is not present, timeout needs to elapse (TOUT). This (TOUT elapsing) paces the unit for processing bus commands.
 - If DETECT ON (only), search time needs to elapse before responding to a bus command.
 - If SEARCH OFF or FAST ON, search time and TOUT are not incurred while processing non-user triggered commands (refer to Section 9 of the User's Manual for examples of user triggered).
 - Search time or TimeOUT needs to elapse when checking TLEV command for valid setting, if enabled.

Table 3-3
PCURrent FAST, SEARch, and DETect commands

FAST	SEARCH	DETECT	DESCRIPTION
ON ON ON ON	ON ON OFF OFF	ON OFF ON OFF	<p>The unit is most responsive to bus commands in this mode. The supply does not wait for TOUT or search time for background pulse current readings and TLEV command checks. Front panel displays FAST HI / LO / AVG (in remote mode) instead of PCUR HI / LO / AVG (if in local mode). The bottom line may show a previous reading or dashes based on what commands were sent previously when in remote mode.</p> <p>With FAST set to ON, no pulse detection between user-triggered readings occurs, no checking for the parameter of PCUR TLEV commands to detect a pulse occurs, no setting of the pulse trigger timeout bits in the status model between user-triggered readings occurs. Front panel has no indication that pulse is not detected. Over the bus, an overflow reading indicates no pulse detected when asked for a user triggered reading.</p> <p>For triggered readings, the PTT (Pulse Trigger Timeout) bit is latched until read so the bit may still be set in the status model from a previous timeout. (See section 7 on the status model for more information-Model 2306 User's Manual.) For triggered readings, the PTT (Pulse Trigger Timeout) bit will be set if the reading times out and the pulse is not detected.</p>
OFF OFF	OFF OFF	ON OFF	<p>The unit is more responsive to bus commands in this mode since the supply does not need to wait for TOUT or search time for pulse current background readings. However, the supply does need to wait for TOUT or search time when checking the parameter setting for TLEV commands. Refer to Figure 3-4. Front panel displays "NO SEARCH" instead of PULSE HI / LO / AVG. The bottom line may show a previous reading or dashes based on what commands were sent previously when in remote mode.</p> <p>The setting of the pulse trigger timeout bits in the status model will only occur between user-triggered readings if TLEV commands are sent. For triggered readings, the PTT (Pulse Trigger Timeout) bit will be set if the reading times out and the pulse is not detected. Also, since the PTT bit is latched until read, the bit may still be set in the status model from a previous timeout. (See section 7 on the status model for more information-Model 2306 User's Manual.)</p>
Shaded cells designate command with precedence in each mode.			

Table 3-3

PCURrent FAST, SEARch, and DETect commands (cont.)

FAST	SEARCH	DETECT	DESCRIPTION
OFF	ON	ON	<p>This mode allows the user to know whether the pulse disappeared before a user-triggered reading is requested. The responsiveness of bus commands is governed by TOUT (if no pulses are detected), or by search time (if pulses are detected). Therefore, the longest response time to bus commands is approximately the greater of either TOUT or search time values. Refer to Figure 3-4.</p> <p>If the pulse is detected, the front panel will display DETECT HI / LO / AV on the top line of the display. If no pulses are detected, the front panel will display "NO DETECT" as well as the PTT (Pulse Trigger Timeout) bit being set in the status model. Since the PTT bit is latched until read, a query for the PTT bit may indicate that pulse trigger timeout occurred although the display is showing DETECT. (See section 7 on the status model for more information-Model 2306 User's Manual.) The bottom line may show a previous reading or dashes based on what commands were sent previously when in remote mode.</p> <p>Checking for the parameter of PCUR TLEV command may set the PTT bit of the status model. For triggered readings, the PTT (Pulse Trigger Timeout) bit will be set if the reading times out and the pulse is not detected.</p>
OFF	ON	OFF	<p>With DETect OFF, background pulse current measurements will occur between user-triggered readings as well as pulse detection. If the pulse is detected, the front panel will display PULSE HI / LO / AVG on the top line of the display along with the reading on the bottom line. If no pulses are detected, the front panel will display "NO PULSE" as well as the PTT (Pulse Trigger Timeout) bit being set in the status model. Since the PTT bit is latched, a query for the PTT bit may indicate that pulse trigger timeout occurred although the display is displaying PULSE HI / LO / AVG and a reading. (See section 7 on the status model for more information-Model 2306 User's Manual.) Checking for the parameter of PCUR TLEV commands to detect a pulse may set the PTT bit. If detecting pulses, the supply's responsiveness to bus commands is affected by search time. If not detecting pulses, the supply's responsiveness to bus commands is affected by TOUT. Therefore, the longest response time to bus commands is approximately the greater of either TOUT or search time (refer to Figure 3-4).</p> <p>In this mode, the front panel will show PULSE HI / LO / AVG on the top line with a reading on the bottom. Checking the parameter of PCUR TLEV commands to detect a pulse may set the PTT bit of the status model if TLEV setting causes no pulse detection. For triggered readings, the PTT (Pulse Trigger Timeout) bit will be set if the reading times out and the pulse is not detected.</p>
Shaded cells designate command with precedence in each mode.			

Pulse current digitization

The following discussion explains how to digitize a current waveform. A programming example at the end of this section demonstrates proper command sequence for pulse current digitization.

Overall steps for digitization:

1. Sync up to desired edge for measurement.
2. After detecting edge, wait for the internal and also any user trigger delay.
3. Take specified number of readings. The supply synchronizes to only the first reading. After taking the first reading, the supply no longer synchronizes to the selected edge nor does it wait for a trigger delay (internal or user trigger delay).

In the pulse current digitization mode, readings are generated approximately every 274 μ s for battery channel (490 μ s for charger channel) and placed in the instrument measurement output buffer. The 274 μ s or 490 μ s time interval is the sum of the integration period, 33 μ sec, and the period required to convert this information into a measurement, approximately 241 μ sec for battery channel (457 μ s for charger channel). The instrument initiates the storage and conversion process for the desired number of iterations, as specified with the AVERAGE command, when the :TLEVEL threshold is exceeded. The message "DIGITIZE" is displayed instead of readings. The "NO PULSE" message will be displayed if the pulse is not detected. Pulse current digitization is selected by disabling trigger synchronization:

```
SENS[1]:PCUR:SYNC <b>          Battery Channel (#1)
SENS2:PCUR:SYNC <b>          Charger Channel (#2)
<b> = OFF    Select pulse current digitization (trigger synchronization disabled).
      = ON    Select pulse current measurements (trigger synchronization enabled).
```

The commands to set the trigger level and trigger delay for pulse current measurements also apply for pulse current digitization. However the trigger delay can be set up to five seconds.

```
SENS[1]:PCUR:SYNC:DEL <NRf> Battery Channel (#1)
SENS2:PCUR:SYNC:DEL <NRf>  Charger Channel (#2)
<NRf> = 0 to 5    User trigger digitization delay in seconds (10 $\mu$ sec steps). For digitization, the internal trigger delay is 15 $\mu$ sec.
```

To detect the pulse, the digitization process synchronizes to the edge specified by the following command:

```
SENS[1]:PCUR:MODE <name>    Battery Channel (#1)
SENS2:PCUR:MODE <name>    Charger Channel (#2)
<name> = HIGH or AVER    Sync up to rising edge of pulse for 1st reading of digitization.
      = LOW              Sync up to falling edge of pulse for 1st reading of digitization.
```

After any specified delay period expires, the instrument takes the number of readings specified by the average count command:

SENS[1]:PCUR:AVER <NRf>	Battery Channel (#1)
SENS2:PCUR:AVER <NRf>	Charger Channel (#2)
<NRf> = 1 to 5000	Digitize 1 to 5000 readings.

NOTE See “Pulse current digitization” on page 3-30 for a programming example.

Pulse current step method

Use the pulse current step method to perform a series of different trigger level measurements on the same trigger level range. This method is available on the battery channel through GPIB operation — SENS:PCUR:STEP commands (see Table 3-2). Use this method to decrease the time required to take a sequence of measurements. To use this method, properly set trigger level steps, integration time, timeout setting, and trigger level range for the entire sequence of measurements. Out of these settings, only trigger level may be set to a unique value for each step — settings for integration time and trigger level range apply to all steps in the measurement sequence. Timeout has two settings — one for the first step and one for the remaining steps in the sequence. Use an array command to trigger this method since an array of values are returned (e.g., :READ[1]:ARRAY?).

TLEV steps

TLEV (trigger level) steps are used to define the pulse sequence. A maximum of 20 steps may be defined. These steps can be all UP steps, all DOWN steps, or a combination with the summation of UP and DOWN steps to measure not exceeding 20 (see Table 3-4). UP steps are always measured before DOWN steps. To use the step method on pulse forms with DOWN steps first, special programming considerations can be taken. Refer to “Pulse sequences — down steps first” on page 3-26.

NOTE Erroneous readings will result if the current range is changed after the trigger level range is selected (Model 2306-PJ only).

When using the Pulse current step method on the Model 2306-PJ, select the current range first (either 5A or 500mA), then select the trigger level range based on that current range before setting the trigger level step values. For the 5A current range, the trigger level range options are 5A, 1A, or 100mA full scale. For the 500mA range, the trigger level range full scale options are 500mA, 100mA, or 10mA. Current range and trigger level range needs to be specified before step values because the step values are shared for all current range and trigger level range options. Selecting the trigger level range is less critical than setting the current range because once on a given current range you may change trigger level ranges and the step values will be verified for being valid on the new range (discussed in more detail later in this section). Because the Model 2306 has one current range (5A), this range is always the order of operation.

Table 3-4
Setting UP and DOWN commands

Command	Description
:SENS:PCUR:STEP:UP 1	$1 \text{ (UP)} + 1 \text{ (DOWN default)} \leq 20$ ∴ this command is ok.
:SENS:PCUR:STEP:UP 20	$20 \text{ (UP)} + 1 \text{ (DOWN)} > 20$ ∴ this command generates an error message (-222, parameter out of range). Both the up and down settings stay at 1.
:SENS:PCUR:STEP:DOWN 3	$3 \text{ (DOWN)} + 1 \text{ (UP)} \leq 20$ ∴ this command is ok.
:SENS:PCUR:STEP:UP 12	$12 \text{ (UP)} + 3 \text{ (DOWN)} \leq 20$ ∴ this command is ok.
:SENS:PCUR:STEP:DOWN 10	$12 \text{ (UP)} + 10 \text{ (DOWN)} > 20$ ∴ this command generates an error message (-222, parameter out of range). The down setting stays at 3.

Active steps refer to valid UP steps plus valid DOWN steps. If pulse current step method is selected when a trigger command is received, the number of measurements taken equals the number of active steps. Therefore, to receive all measurements at once, use array commands. If array commands are not used, then a single reading is returned. This single reading represents the average of the active step measurements.

NOTE *If there are zero (0) active steps when a trigger command for step is received (number of steps UP + the number of steps DOWN = 0), one reading will be returned (an overflow).*

The step method can be used on a variety of pulse forms. See Figure 3-5 for pulse forms that can be measured either as one-shot pulse or as a continuous pulse train. For other pulse forms that can be measured as one-shot only pulses, see Figure 3-6. For pulse trains that have steps that rise and fall between steps, use the one-shot method to measure the step values (see “Pulse sequences — rising and falling” on page 3-25). If the continuous method is used on these pulse trains, the first step may trigger on any step that would be appropriate for that trigger level. For example, a first step trigger level of 200 milliamps may trigger on any step with an expected value greater than 200 milliamps. Figure 3-8 shows that with a first step TLEV of 200 milliamps that any one of the six steps may actually trigger as a first step reading. Hence, the array of step readings may have overflow readings and/or expected step values out of sequence. In addition, this would vary between triggered step measurements.

Figure 3-5
Sample pulse forms for step method

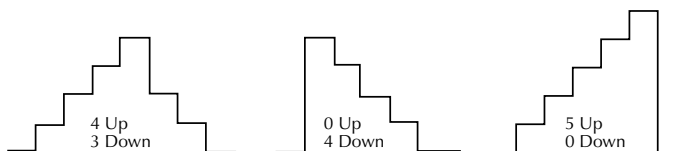

Figure 3-6
Sample one-shot only pulses for step method



Trigger level settings

The trigger level may be set to a unique value for each active step. Use the `TLEVx` command to set appropriate trigger levels for each active step in the waveform. Make sure that the maximum setting for the selected trigger level range is not exceeded. (See “Trigger level range” on page 3-28.)

Figure 3-7 has 5 rising edge steps and 4 falling edge steps. Set the trigger levels for each step measurement according to the expected pulses. Based on the wave form, the nine trigger levels could be set as follows:

Rising:		Falling:	
TLEV1	100mA	TLEV6	900mA
TLEV2	300mA	TLEV7	600mA
TLEV3	500mA	TLEV8	400mA
TLEV4	700mA	TLEV9	300mA
TLEV5	900mA		

For a programming example of this sample, see “Sample step method” on page 3-31.

Figure 3-7
Sample :STEP Pulse measurement

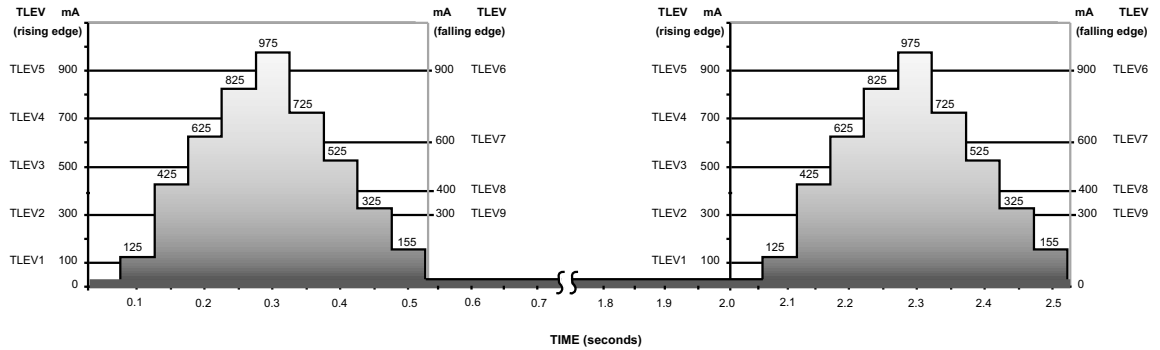

Pulse sequences — rising and falling

Consider the pulse form in Figure 3-8. This pulse form has three falling (DOWN) level steps followed by three rising (UP) level steps. Since these steps rise and fall to the same steady state current, active steps need to be designated as 6 UP and 0 DOWN to measure the step level current. If DOWN steps are specified then, the step level current measured will be the steady state current.

Figure 3-8
Pulse form with rise and fall steps

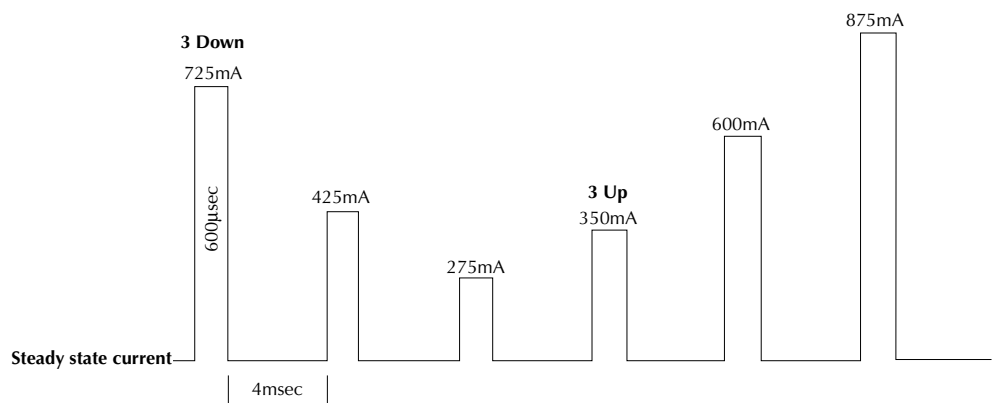

For the active steps, the trigger level may be set to a value appropriate for each rising or falling step, or set to the same value for all active steps. If using the same values for all TLEV_x steps, make sure the TLEV value set is appropriate for the smallest step (in Figure 3-8, the TLEV value could not be greater than 275mA). See Table 3-5 for sample trigger level values.

Table 3-5
Sample TLEV values for Figure 3-8

TLEV _x	Unique TLEV _x value	Same TLEV _x value
TELV1	550mA	200mA
TELV2	325mA	200mA
TELV3	200mA	200mA
TELV4	300mA	200mA
TELV5	500mA	200mA
TELV6	800mA	200mA

Use the one-shot method for measuring the pulses since this pulse sequence rises and falls between steps. To accomplish this, configure the Model 2306 for measuring the pulse sequence then generate the pulse sequence. (See the programming example “One-shot pulse” on page 3-26).

Pulse sequences — down steps first

Consider the pulse form in Figure 3-9. This pulse form has three DOWN steps followed by three UP steps but does not rise or fall between the steps.

Figure 3-9
Pulse form with down steps first (600μsec step duration)

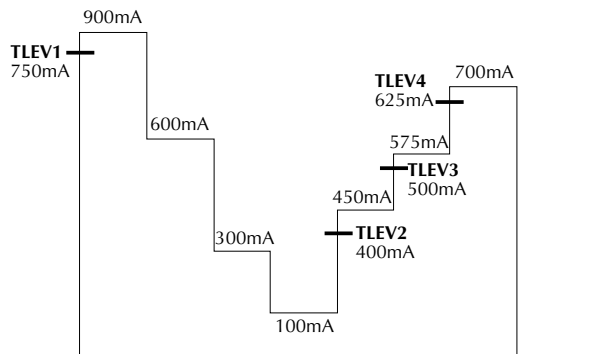

To measure the up step values in this pulse sequence, set the value for UP steps to equal the sum of actual UP steps plus one while setting the DOWN step value to zero. In Figure 3-9, the UP steps are set to 4 and DOWN steps to 0. (If UP steps are set to a non-zero value, the Model 2306 measures them first.) Also set TLEV1 for the initial step. This value needs to be appropriate for detecting the first DOWN step as an UP step measurement (in Figure 3-9, this value is set at 750mA). For the UP steps, set the trigger level to a value appropriate for each rising step. The key to detecting this pulse sequence is setting the step timeout to a value high enough to bypass the remaining down steps after measuring the first step.

For Figure 3-9, the following expected measurement values and TLEVs were used:

Expected measurements

UP 450mA, 575mA, and 700mA (4th–6th pulses)

DOWN 900mA, 600mA, 300mA (1st-3rd pulses)

TLEVs (all rising)

TLEV1	750mA (1st pulse)	TLEV3	500mA (5th pulse)
TLEV2	400mA (4th pulse)	TLEV4	625mA (6th pulse)

This pulse sequence can be measured using the continuous pulse method (see the programming example “Continuous pulse train” on page 3-33). Similarly, this pulse train could be measured using the one-shot method. For the one-shot method, the first step trigger level value could be any value for detecting the 900 milliamp step.

Timeout setting

TOUT (TimeOUT — timeout setting) specifies the timeout length for detecting a given pulse step. When the TOUT value is reached, an overflow value for that step reading is returned. Although all step measurements after the first TOUT step are returned as overflow readings, all step measurements performed before TOUT was exceeded will have correct readings.

Two timeout settings are used: one for the initial step and another for the rest of the active steps. The setting for the initial timeout should be set slightly longer than the period of the pulse for continuous pulse trains. The other timeout setting should cover the longest step duration. Also, make sure to account for trigger delays when determining timeout settings. There are two possible trigger delays: the internal trigger delay (15µsec necessary for code execution), and any user specified trigger delay (optional). The trigger delays occur before the integration process begins but after pulse detection.

To use the pulse current step method to measure a one-shot pulse train, set the initial timeout to the maximum setting of 60 seconds. This allows the Model 2306 to be triggered for step measurements, then a few seconds of delay before generating the one-shot pulse train. The few seconds of delay are required to ensure the Model 2306 is setup and ready to detect the first step when it happens along with the rest of the steps.

Integration time

For the pulse current step method, the integration time is required to be at least 400 μ sec less than the step duration. This 400 μ sec allows for the Model 2306 to complete the previous measurement conversion and become ready for the next pulse edge. With this in mind, Table 3-6 lists appropriate integration times. Integration time applies to all active steps when step measurements are requested — each step has the same integration time.

Table 3-6
Sample integration times

Pulse step duration	Step integration times
3.8ms	≤ 3.4 ms
1.25ms	≤ 0.85 ms
800 μ sec	≤ 400 μ sec
500 μ sec	≤ 100 μ sec

Trigger level range

Select an appropriate trigger level range for the desired measurements. For the Model 2306 and 2306-PJ (5A current range), three trigger level ranges are available: 5 amps, 1 amp and 100 milliamps. For the Model 2306-PJ, the step readings can also be taken on the 500mA current range which adds the 500mA, 100mA, and 10mA trigger level ranges. Make sure all TLEV values are valid in the selected trigger level range. There is only one trigger level range for all active steps — each step does not have a unique trigger level range.

Changing ranges

When changing ranges, the currently active TLEV (trigger level) step values are checked. This check verifies that the new range maximum setting does not exceed the range (i.e., 5A for 5A range, 1A for 1A range, or 100mA for 100mA range). If just one of the active step TLEV values exceeds the maximum setting for the new range, then all step TLEV values are set to 0A.

For example: When changing from the 5 amp range to the 1 amp range, a TLEV greater than 1 amp zero's out all active trigger level values. On the other hand, if changing from the 5 amp range to the 1 amp range and no trigger level settings exceed 1 amp, the previous settings will be used for the 1 amp range.

NOTE Change TLEV settings for each step using the `:STEP:TLEVx` command.

Programming examples

The following programming examples apply to the Model 2306 or 2306-PJ on the 5A current range. To modify the examples to apply to the 500mA current range (Model 2306-PJ only):

1. Change the `SENS:CURR:RANG` command line to select the 500mA current range.
2. Change the trigger level commands to appropriate commands for the 500mA current range. In the examples, the command lines requiring this modification are italicized.

Pulse current measurements

The following command sequence will return the average of 10 peak pulse current measurements:

Battery channel (#1)

```

DISP:CHAN 1           ` Sets active channel - battery.
SENS:CURR:RANG 5     ` Select 5A range.
VOLT 15              ` Set output voltage to 15V.
CURR 0.75            ` Set current limit to 750mA.
OUTP ON              ` Turn output on.
SENS:PCUR:SYNC ON   ` Enable trigger synchronization.
SENS:PCUR:AVER 10    ` Set average count to 10.
SENS:PCUR:SYNC:TLEV:RANG 0.5 ` Select the 1A trigger level range.
SENS:PCUR:SYNC:TLEV:ONE 0.1 ` Set trigger level to 100mA for 1A trigger
                             ` level range.
SENS:PCUR:TIME:AUTO ` Set integration times automatically.
SENS:FUNC "PCUR"     ` Select pulse current function.
SENS:PCUR:MODE HIGH ` Configure to measure peak pulse.
READ?                ` Trigger 10 measurement conversions and
                             ` return the average of those 10 conver-
                             ` sions. The average of the 10 conversions
                             ` is displayed on the front panel. Each of
                             ` the ten conversion syncs to the rising
                             ` edge.

```

Charger channel (#2)

```

DISP:CHAN 2           ` Sets active channel - charger.
SENS2:CURR:RANG 5     ` Select 5A range.
SOUR2:VOLT 15         ` Set output voltage to 15V.
SOUR2:CURR 0.75       ` Set current limit to 750mA.
OUTP2 ON              ` Turn output on.
SENS2:PCUR:SYNC ON   ` Enable trigger synchronization.
SENS2:PCUR:AVER 10    ` Set average count to 10.
SENS2:PCUR:SYNC:TLEV 0.1 ` Set trigger level to 100mA.
SENS2:PCUR:TIME:HIGH 600e-3 ` Set integration high time to 600ms.
SENS2:PCUR:SYNC:DEL 50e-3 ` Set trigger delay to 50msec.
SENS2:FUNC "PCUR"     ` Select pulse current function.
SENS2:PCUR:MODE HIGH ` Configure to measure peak pulse (trigger
                             ` on rising edge).
READ2?                ` Trigger 10 measurement conversions and
                             ` return the average of those 10 conver-
                             ` sions. The average of the 10 conversions
                             ` is displayed on the front panel. Each of
                             ` the ten conversion syncs to the rising
                             ` edge.

```

Pulse current digitization

The following command sequence returns 3600 digitized readings.

Battery channel (#1)

```

DISP:CHAN 1           ` Sets active channel - battery.
SENS:CURR:RANG 5     ` Select 5A range.
VOLT 15              ` Set output voltage to 15V.
CURR 0.75            ` Set current limit to 750mA.
OUTP ON              ` Turn output on.
SENS:PCUR:SYNC OFF   ` Disable trigger synchronization.
SENS:PCUR:AVER 3600  ` Set average count to 3600.
SENS:PCUR:SYNC:TLEV:RANG 0.5 ` Select the 1A trigger level range.
SENS:PCUR:SYNC:TLEV:ONE 0.1 ` Set trigger level to 100mA for 1A range.
SENS:PCUR:SYNC:DEL 500-3 ` Set trigger delay to 500msec.
SENS:FUNC "PCUR"     ` Select pulse current function.
SENS:PCUR:MODE LOW   ` Configure to measure low pulse (trigger on
                       ` falling edge).
READ:ARR?            ` Trigger and return 3600 readings after sync-
                       ` ing to the falling edge for the 1st reading
                       ` only.

```

Charger channel (#2)

```

DISP:CHAN 2           ` Sets active channel - charger.
SENS2:CURR:RANG 5     ` Select 5A range.
SOUR2:VOLT 15         ` Set output voltage to 15V.
SOUR2:CURR 0.75       ` Set current limit to 750mA.
OUTP2 ON              ` Turn output on.
SENS2:PCUR:SYNC OFF   ` Disable trigger synchronization.
SENS2:PCUR:AVER 3600  ` Set average count to 3600.
SENS2:PCUR:SYNC:TLEV 0.1 ` Set trigger level to 100mA.
SENS2:PCUR:SYNC:DEL 50e-3 ` Set trigger delay to 50msec.
SENS2:FUNC "PCUR"     ` Select pulse current function.
SENS:PCUR:MODE LOW   ` Configure to measure low pulse (trigger on
                       ` falling edge).
READ2:ARR?           ` Trigger and return 3600 readings after sync-
                       ` ing to the falling edge for the 1st reading
                       ` only.

```

Pulse current STEP method (battery channel only)

NOTE For the Model 2306-PJ to function correctly, the current range must be selected before selecting the trigger level range.

Sample step method

The following command sequence measures pulses similar to the one shown in Figure 3-7. The step duration is 50ms with a pulse period of 2 seconds.

```

DISP:CHAN 1           ` Set active channel - battery.
SENS:CURR:RANG 5     ` Select 5A current range.
SENS:FUNC 'PCUR'    ` Select PCUR function.
SENS:PCUR:STEP ON    ` Enable step.
SENS:PCUR:STEP:UP 5  ` Specify 5 up steps.
SENS:PCUR:STEP:DOWN 4 ` Specify 4 down steps
                    ` active steps = 9 (5 up + 4 down).
SENS:PCUR:STEP:TIME 20e-3 ` Specify 20 milliseconds integration time
                    ` for all active steps must be within 400µsec
                    ` of step duration.
SENS:PCUR:STEP:RANGE 0.75 ` Specify 1 amp step range.
SENS:PCUR:STEP:TOUT:INIT 3 ` Specify 3 seconds for first step timeout
                    ` (this has to be longer than pulse period).
SENS:PCUR:STEP:DEL 10e-3 ` Specify 10 milliseconds for user step delay.
                    ` With 50 milliseconds of step duration, we
                    ` use 50 milliseconds (step duration) -
                    ` 30 milliseconds = 20 milliseconds spare time.
                    ` Recall 400 microseconds needed for complet-
                    ` ing previous step measurement and being
                    ` ready for next.
SENS:PCUR:STEP:TLEV1 100e-3 ` Step 1 tlev value.
SENS:PCUR:STEP:TLEV2 300e-3 ` Step 2 tlev value.
SENS:PCUR:STEP:TLEV3 500e-3 ` Step 3 tlev value.
SENS:PCUR:STEP:TLEV4 700e-3 ` Step 4 tlev value.
SENS:PCUR:STEP:TLEV5 900e-3 ` Step 5 tlev value.
SENS:PCUR:STEP:TLEV6 900e-3 ` Step 6 tlev value.
SENS:PCUR:STEP:TLEV7 600e-3 ` Step 7 tlev value.
SENS:PCUR:STEP:TLEV8 400e-3 ` Step 8 tlev value.
SENS:PCUR:STEP:TLEV9 300e-3 ` Step 9 tlev value.
READ:ARR?           ` Trigger and return the 9 step measurements.

```

NOTE Since this sample program is for a continuous pulse train, the pulse it measures could also be measured using the single shot method. (See "One-shot pulse" on page 3-32.)

One-shot pulse

NOTE For the Model 2306-PJ to function correctly, the current range must be selected before selecting the trigger level range.

The following command sequence measures pulses similar to the one shown in Figure 3-8 with a one-shot pulse measurement. The step duration is 600µsec with 4msec between steps.

```

DISP:CHAN 1           ` Set active channel - battery.
SENS:FUNC 'PCUR'     ` Select PCUR function.
SENS:PCUR:STEP ON    ` Enable step.
SENS:PCUR:STEP:UP 6  ` Specify 6 up steps.
SENS:PCUR:STEP:DOWN 0 ` Specify 0 down steps (remember the default
                    ` is 1). See "Pulse sequences - rising and
                    ` falling" on page 3-25 for more information.
SENS:CURR:RANG 5     ` Select 5A current range.
SENS:PCUR:STEP:RANGE .75 ` Specify 1 amp range.
SENS:PCUR:STEP:TIME 100e-6 ` Specify 100 microseconds for step integra-
                    ` tion time.
SENS:PCUR:STEP:DEL 50e-6 ` Specify 50 microseconds for step delay.
                    ` Recall 400 microseconds needed for complet-
                    ` ing previous step measurement and being
                    ` ready for next. With 600 microseconds of
                    ` step duration, we have 50 microseconds to
                    ` spare:
                    ` 600 (step duration) - 400 (step processing
                    ` time) - 100 (step integration time) -
                    ` 50(step delay) = 50 (spare time).
SENS:PCUR:STEP:TOUT 8e-3 ` Specify 8 milliseconds for step timeout ex-
                    ` cept first one.
SENS:PCUR:STEP:TOUT:INIT 60 ` Specify 60 seconds for first step timeout.
                    ` Recall for one shot pulse measurement, need
                    ` to have a long initial step timeout since
                    ` want to trigger the 2306 for pulse step mea-
                    ` surement and wait between 3 to 5 seconds be-
                    ` fore generating the one shot pulse to guar-
                    ` antee the Model 2306 is waiting for
                    ` detection of first step.
                    ` Using the same step trigger level for all steps is contained in the
                    ` following sample. Table 3-5 contains a sample with the one
                    ` trigger level (as shown) and also with unique trigger levels for each
                    ` step.
SENS:PCUR:STEP:TLEV1 200e-3 ` Step 1 TLEV value.
SENS:PCUR:STEP:TLEV2 200e-3 ` Step 2 TLEV value.
SENS:PCUR:STEP:TLEV3 200e-3 ` Step 3 TLEV value.
SENS:PCUR:STEP:TLEV4 200e-3 ` Step 4 TLEV value.
SENS:PCUR:STEP:TLEV5 200e-3 ` Step 5 TLEV value.
SENS:PCUR:STEP:TLEV6 200e-3 ` Step 6 TLEV value.
READ:ARR?             ` Trigger and return the 6 step measurements
                    ` After sending this command, wait a few seconds before generating a one
                    ` shot pulse sequence.

```

Continuous pulse train

NOTE For the Model 2306-PJ to function correctly, the current range must be selected before selecting the trigger level range.

The following command sequence measures pulses similar to the one shown in Figure 3-9 in a continuous pulse train. The step duration is 600 μ sec with a step period of 2 seconds.

```

DISP:CHAN 1           ` Set active channel - battery.
SENS:CURR:RANG 5     ` Select 5A current range.
SENS:FUNC 'PCUR'    ` Select PCUR function.
SENS:PCUR:STEP ON   ` Enable step.
SENS:PCUR:STEP:UP 4 ` Specify 4 up steps.
SENS:PCUR:STEP:DOWN 0 ` Specify 0 down steps.
SENS:PCUR:STEP:RANGE .75 ` Specify 1 amp range.
SENS:PCUR:STEP:TIME 100e-6 ` Specify 100 microseconds for step
                           ` integration time.
SENS:PCUR:STEP:DEL 50e-6 ` Specific 50 microseconds for step delay.
                           ` Recall 400 microseconds needed for complet-
                           ` ing previous step measurement and being
                           ` ready for next. With 600 microseconds of
                           ` step duration, we have 50 microseconds to
                           ` spare:
                           ` 600 (step duration) - 400 (step processing
                           ` time) - 100 (step integration time) -
                           ` 50(step delay) = 50 (spare time).
SENS:PCUR:STEP:TOUT 3e-3 ` Specify 3 milliseconds for step
                           ` timeout except for first step. Recall
                           ` timeout needs to be long enough to bypass
                           ` the 600mA, 300mA, and 100mA steps, but not
                           ` so short it misses the 450mA step (600 $\mu$ sec x
                           ` 3 = 1.8 msec). Using 3msec accounts for the
                           ` first step spare time as well.
SENS:PCUR:STEP:TOUT:INIT 3 ` Specify 3 seconds for first step timeout.
                           ` Recall for continuous pulse measurement,
                           ` need to have an initial step timeout long
                           ` enough to bypass the pulse period.
SENS:PCUR:STEP:TLEV1 750e-3 ` Step 1 tlev value.
SENS:PCUR:STEP:TLEV2 400e-3 ` Step 2 tlev value.
SENS:PCUR:STEP:TLEV3 500e-3 ` Step 3 tlev value.
SENS:PCUR:STEP:TLEV4 625e-3 ` Step 4 tlev value.
READ:ARR?           ` Trigger and return the 4 step measurements.

```

Long Integration Measurements

- **Overview** — Provides an overview of the long integration measurement process.
- **Measurement configuration** — Explains how to configure the instrument for long integration measurements.
- **Long integration measurement procedure** — Provides the step-by-step procedure to perform long integration measurements from the front panel.
- **SCPI programming** — Documents the commands used to program the instrument for long integration measurements including FAST, SEARCh and DETect usage.
- **Programming examples** — Include programming examples to perform long integration measurements.

NOTES This manual covers Keithley Models 2302, 2302-PJ, 2306, and 2306-PJ simulators (power supplies). Since the Model 2302 and 2302-PJ are single channel battery simulators, functions related to the second channel (i.e., the charger channel) are not available for the Model 2302 and 2302-PJ. Therefore:

- *battery and charger channel features contained in this manual apply for the Model 2306 and 2306-PJ*
- *only battery channel features contained in this manual apply for the Model 2302 and 2302-PJ*

Refer to Appendix F for specific Model 2302 and 2302-PJ information.

Information contained in this section applies to all power supply channels (unless otherwise noted). In this manual, channel 1 refers to the battery channel while channel 2 refers to the charger channel (2306 and 2306-PJ feature only).

Overview

Long integration is an average current measurement of one or more pulses that can be performed on either the battery channel or the charger channel. The integration time can be as long as 60 seconds. Since long integration is an average measurement, the integration time should be a complete pulse period or an integral number of pulse periods.

Long integration measurements are accomplished by taking an integral number of integration cycles during the total measurement time. An integration cycle is the line cycle period (16.67ms for 60Hz) plus a small processing time. The system calculates the number of integration cycles required based on the total time and rounds down to the nearest integer. Therefore, the actual measurement time can be slightly less than the requested measurement time by up to one line cycle time (one cycle is 16.67ms for 60 Hz and 20ms for a 50 Hz line frequency). A long integration reading, R_I , is the average of a series of current measurements, m_i , defined by:

$$R_I = \frac{\sum_{k=1}^n m_i}{n}$$

where n is an integer given by:

$$n = \text{int} \left\{ \frac{I_t}{1 \text{ PLC}} \right\}$$

where:

1PLC = one power line cycle

I_t = integration time

Here the integration time specified by the user and denominator represents the integration time of 1 PLC (16.67 msec for 60Hz or 20 ms for 50Hz) and processing overhead. The function int rounds the argument down to next lowest integer.

Long integration is a technique to extend the capabilities of the power supply A/D circuit beyond its maximum integration time period. The A/D can measure pulses up to 833ms. To extend this time period for longer pulses, the long integration technique uses a filtered and sampled measurement of the waveform. This gives the power supply the ability to measure signals with periods up to 60 seconds.

The filtering of the waveform adds some restrictions to the types of pulses being measured. If a pulse train has a high duty cycle, where the off time is less than 200ms, the first period of the measured waveform will not have settled to steady state, therefore it will be an inaccurate measurement. In all cases where the off or low time is less than 200ms, the filtered pulse will have reached steady state in the second cycle of the waveform and, therefore, can be accurately measured (Figure 4-1). In other words, to measure a periodic waveform with low times less than 200ms (high duty cycle), start measurements after the first period occurs. This is not a problem for one-shot pulses or for pulses with off times greater than 200ms.

Figure 4-1
Steady state for waveforms
based on low pulse times

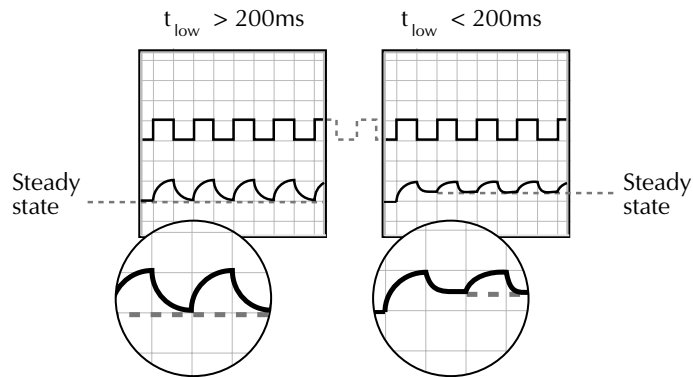

Integration time

The integration time period can be set automatically or manually by the user. The integration time can be as long as 60 seconds. For 60Hz power line frequency, the minimum integration time setting is 850msec. For 50Hz power line frequency, the minimum integration setting is 840msec.

Use AUTO TIME when you want to perform a long integration measurement of each pulse. When the AUTO TIME operation is performed, the instrument measures the time between two rising pulse edges and sets an appropriate integration time that will encompass the high and low periods of the pulse. This integration time applies for all subsequent long integration measurements until another AUTO TIME is performed or the time is changed manually.

If you want the integration period to encompass two or more pulses, you will have to set the integration time manually. However, you must make sure that the integration time covers only the portion of the pulse you want to measure. For example, if you want a long integration of two pulses, you must make sure that the set integration time does not extend into the third pulse.

Trigger edge

A pulse edge can be used to trigger the start of the measurement. Either a rising or a falling pulse edge can start the measurement. A pulse has to be detected before a rising or falling pulse edge can trigger a long integration measurement. All pulses that are less than the specified trigger level are ignored (see “Trigger level” on page 4-4). Pulse edges are ignored while a long integration is in process.

A third option is available if you do not want measurements controlled by pulse edges. With NEITHER selected, measurements start as soon as the long integration function is selected. This option does not need a valid trigger level to generate a reading. It will perform a measurement and produce a reading of the current even if a pulse is not present. Therefore, with NEITHER selected, the NO PULSE message will not appear on the display.

Trigger level

Before a rising or falling pulse edge can trigger the start of a long integration, the pulse must first be detected. Trigger level specifies the minimum pulse level that will cause detection. For example, if the trigger level is set for 2A, pulses that are $\geq 2A$ will be detected. Current pulses $< 2A$ are ignored.

The charger channel has only one trigger level range: 0–5A. For the Model 2306 and 2306-PJ on the 5A current range, the battery channel has three trigger level range settings: 5A, 1A, or 100mA trigger level ranges. For 5A, the level may be set from 0 to 5A. For the 1A range, the trigger level may be set from 0 to 1A. Likewise, the level may be set from 0 to 100mA for the 100mA trigger level range. On the Model 2306-PJ, you can also measure on the 500mA current range. Therefore, the 2306-PJ has three additional trigger level range settings for the 500mA current range: 0-500mA, 0-100mA, and 0-10mA. These ranges affect trigger level resolution and not the current range since long integration readings are always performed on the 5A current range. The trigger level range option on battery channel allows the user to set a trigger level with greater resolution.

Trigger level range

This setting affects long integration trigger level and has no effect on current range setting since long integration measurements are always performed on the 5A current range. For the Model 2306 and 2306-PJ on the 5A current range, three settings (battery channel only) are available: 5A, 1A, or 100mA. Use the range that provides adequate trigger level resolution (a 100mA range provides a greater available resolution for trigger level than does the 1A range). When using the Model 2306-PJ's 500mA current range, the three trigger level range settings are: 500mA (0.5mA step), 100mA (0.1mA step), and 10mA (0.1mA step).

Pulse timeout

TOUT (timeout) specifies the timeout length for the pulse. When the TOUT value is reached, NO PULSE is displayed (top line of the front panel display). Set the value for TOUT as follows:

$$TOUT = LINT\ TIME + x$$

where x makes $TOUT > LINT\ TIME$

$TOUT =$ timeout (time allowed for detection of a pulse)

$LINT\ TIME =$ long integration time (time allowed for reading after pulse occurs)

For example, if the trigger edge is set to rising, the timeout value should be set to allow sufficient time for detection of the pulse if the rising edge is just missed. In Figure 4-2, point (A) is the point where we start looking for the pulse. Since the rising edge was just missed, point (B) will be the first detectable rising edge. If the timeout is less than long integration time, a pulse trigger time out (due to TOUT) may occur. Therefore, if long integration time = 1.8 seconds, a good TOUT value would be 2 seconds. A similar method for selecting a TOUT value would be to use a value equal to 105% of the expected pulse period.

Figure 4-2
Long integration, search, and reading time comparison

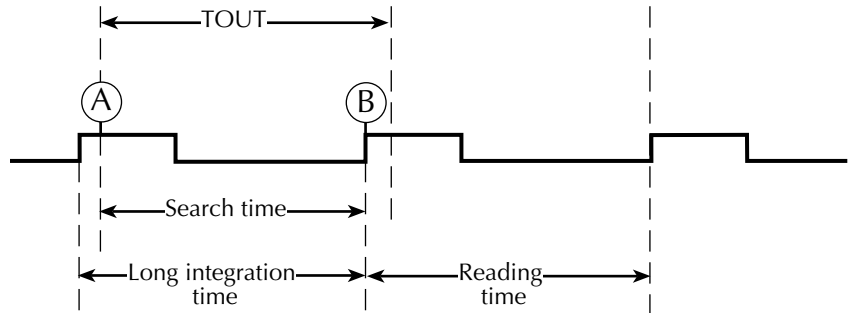

Summarizing Figure 4-2:

1. Reading begins searching for high pulse at point (A).
2. Earliest pulse detected at point (B).
3. Reading time equals Long integration time.

- NOTES**
- If a pulse is not present, timeout needs to elapse (TOOUT) before “NO PULSE” appears on the display.
 - Search Time needs to elapse when checking TLEV command for valid setting.

PULSE TIMEOUT applies only to long integration measurements that are configured to be triggered by rising or falling pulse edges. After the long integration function is selected, the instrument searches for a pulse. If a pulse is not detected within the specified time (PULSE TIMEOUT), the “NO PULSE” message will be displayed. While the “NO PULSE” message is displayed, the instrument continues to search for a pulse. With a long timeout setting, the instrument may appear locked up while it is searching for the pulse to start the long integration. PULSE TIMEOUT can be set from 1.000 to 63.000 seconds.

With neither trigger edge selected, pulse timeout is not used and a pulse search is not conducted. Therefore, the “NO PULSE” message is never displayed. Measurements start as soon as the long integration function is selected, even if no pulse is present. It is the responsibility of the user to determine if a pulse was present when the measurement was made.

NOTES For GPIB operation:

1. use `:SEARCh` to disable the search for pulses (see the `:SEARCh` command in Table 4-2).
2. `:FAST` (enables a fast readings mode) can be used with long integration functionality (see the `:FAST` command in Table 4-2).
3. `:DETEct` may be enabled to only detect pulses between user triggered readings (see the `:DETEct` command in Table 4-2).
4. also see “Using FAST, SEARCh, and DETect” on page 4-15.

Measurement configuration

NOTE Current range is selected from the *CURRENT RANGE #1/#2* item of the menu. Integration time, trigger edge, trigger level range, trigger level, and pulse timeout are set from the *LONG INTEGRAT #1/#2* item of the menu. Details on integration time, trigger edge, trigger level range, trigger level, and pulse timeout are provided in the “Overview”.

Table 1-3 shows the menu structure. Rules to navigate the menu follow the table.

Current range

For long integration measurements, the AUTO range selection is functionally a no-op (no operation). The instrument will not autorange with the long integration measurement function selected. Long integration measurements are always performed on the 5A range. Therefore, selecting long integration with the 5mA range active will cause the supply to first switch to the 5A range.

NOTE To get better trigger level resolution, make sure the trigger level range is set appropriately for the expected measurement (set from *TRIG LEVEL RANGE* under *LONG INTEGRAT #1* menu).

Current range is linked to current limit. Therefore, as a general rule, the user selects the current range before setting the current limit. See “Outputting voltage and current” (in Section 2) for details on current range and current limit. Current range is selected from *CURRENT RANGE #1/#2* item of the menu (*CURRENT RANGE #1* refers to the battery channel while *CURRENT RANGE #2* refers to the charger channel).

Integration time

Use the following items of the *LONG INTEGRAT #1/#2* menu item to set the integration time. (*LONG INTEGRAT #1* refers to the battery channel while *LONG INTEGRAT #2* refers to the charger channel).

INTEGRATION TIME

Manually set the long integration time. For 60Hz power line frequency, integration time can be set from 850msec to 60 sec (1 ms step value). For 50Hz power line frequency, integration time can be set from 840msec to 60 sec (1 ms step value).

AUTO TIME

Use to automatically set the integration time. When the *AUTO TIME* operation is performed, the instrument measures the time between two rising pulse edges and sets an appropriate integration time that will encompass the high and low periods of a single pulse.

AUTO TIME searches for two consecutive RISING edges. (The setting of trigger edge does not affect AUTO TIME.) Therefore, with NEITHER edge set, the PTT (Pulse Trigger Timeout) bits in the status model may get set. (See section 7 on the status model for more information.) Although autotime does not use the user setting for trigger edge, the user setting will be used for trigger commands (e.g., READ?, MEASure?, etc.).

Pulse timeout

Use the PULSE TIMEOUT item of the LONG INTEGRAT #1/#2 menu item to set pulse timeout. (LONG INTEGRAT #1 refers to the battery channel while LONG INTEGRAT #2 refers to the charger channel.)

Set pulse timeout (from 1 to 63 seconds) for long integration measurements that are configured to be triggered by RISING or FALLING pulse edges. If a pulse is not detected within the specified time (PULSE TIMEOUT), the “NO PULSE” message will be displayed. While the “NO PULSE” message is displayed, the instrument continues to search for a pulse. With NEITHER edge selected, the PULSE TIMEOUT setting is inactive.

Trigger edge, trigger level, and trigger level range

Use the following items of the LONG INTEGRAT#1/#2 menu item to set trigger edge, trigger level, and trigger level range. (LONG INTEGRAT #1 refers to the battery channel while LONG INTEGRAT #2 refers to the charger channel.)

Trigger edge

A pulse edge can be used to trigger the start of the measurement (TRIGGER EDGE). Select RISING to use a rising pulse edge to start the measurement. Select FALLING to use a falling pulse edge to start the measurement. A third option is available if you do not want measurements controlled by pulse edges. With NEITHER selected, measurements will start as soon as the long integration function is selected. A pulse has to be detected before a RISING or FALLING pulse edge can trigger a long integration measurement (see “Trigger level” on page 4-4).

Trigger level

Before a RISING or FALLING pulse edge can trigger the start of a long integration, the pulse must first be detected. TRIGGER LEVEL specifies the minimum pulse level that will cause detection on the Model 2306 and 2306-PJ when on the 5A current range. For the 2306-PJ, when on the 500mA current range, use TRIGGER LEVEL mA to specify the minimum pulse level detection on this current range.

For the Model 2306 and 2306-PJ (battery channel #1) 5A current range — The trigger level can be set for either the 5A, 1A, or 100mA range. For the 5A range, the trigger level can be set from 0 to 5A in 5mA steps. For the 1A range, the trigger level can be set from 0 to 1A in 1mA steps. For the 100mA range, the trigger level can be set from 0 to 100mA in 0.1mA steps.

The three trigger level ranges are displayed as follows using the TRIGGER LEVEL menu option:

```

5A Range:           LINT TRIG LEVEL #1
                   A (5.0)    0.000A
1A Range:           LINT TRIG LEVEL #1
                   A (1.0)    0.000A
100mA Range:       LINT TRIG LEVEL #1
                   mA (100)   0.0000A

```

For Model 2306-PJ (battery channel #1) 500mA current range — The trigger level can be set for either the 500mA, 100mA, or 10mA range. For the 500mA range, the trigger level can be set from 0 to 500mA in 0.5mA steps. For the 100mA range, the trigger level can be set from 0 to 100mA in 0.1mA steps. For the 10mA range, the trigger level can be set from 0 to 10mA in 0.1mA steps.

The three trigger level ranges are displayed as follows using the TRIGGER LEVEL mA menu option:

```

500mA Range:       LINT TLEV mA #1
                   mA (500)   0.0000A
100mA Range:       LINT TLEV mA #1
                   mA (100)   0.0000A
10mA Range:        LINT TLEV mA #1
                   mA (10)    0.0000A

```

To toggle the range for the trigger level, place the blinking cursor on the “A” at the far right end of line two of the display, and press the ▲ and ▼ key. After keying in the trigger level (in amps), press ENTER to update the displayed range for that trigger level setting only.

Charger Channel (#2) — Set the trigger level from 0 to 5A in 5mA steps.

Trigger level range

TRIGGER LEVEL RANGE is a battery channel (#1) setting only. Use to specify the trigger level range. On the 5A current range (Models 2306 and 2306-PJ), possible Trigger Level Ranges are:

```

5A FULL SCALE      (0–5A)
1A FULL SCALE      (0–1A)
100mA FULL SCALE   (0–100mA)

```

For the 500mA current range (Model 2306-PJ), using the TRG LEV mA RANGE menu option, possible trigger level ranges are:

```

500mA FULL SCALE   (0–500mA)
100mA FULL SCALE   (0–100mA)
10mA FULL SCALE    (0–10mA)

```

Long integration display mode

Long integration measurements are displayed with the long integration display mode selected. This display mode is selected as follows:

NOTE *To display measured readings if the instrument is in the settings mode, press the SET key until the blinking stops (the measured readings can then be displayed). To determine if the instrument is in the settings mode, check for a blinking cursor in a digit of the voltage or current field (if present, the instrument is in the setting mode).*

1. Press the DISPLAY key to access the display menu.
2. If the desired active display is not selected, use the ◀ and ▶ keys to toggle the active display. The top line of the display will show which display is active as either DISPLAY TYPE #1 or DISPLAY TYPE #2.
3. Scroll through the DISPLAY menu ▲ or ▼ key until “LONG INTEGRATION” is displayed and press ENTER.

NOTE *For details on display modes, see “Display modes” in Section 1.*

Long integration measurement procedure

The following steps summarize the procedure to perform long integration current measurements:

1. Set the output voltage and current limit, and press OPERATE.

NOTE *Setting the trigger level with the output off will also cause the pulse timeout message to appear. However, the trigger level will be set.*

2. When using the battery channel, select the desired trigger level range (5A, 1A, or 100mA) from the TRIG LEVEL RANGE item of the LONG INTEGRAT #1 menu. For both channels, long integration measurements are automatically performed on the 5A current range.
3. From the LONG INTEGRAT #1/#2 item of the menu, set integration time, pulse timeout, trigger edge and trigger level as appropriate. (LONG INTEGRAT #1 refers to the battery channel while LONG INTEGRAT #2 refers to the charger channel.) If using the battery channel (#1), make sure to set the trigger level for the trigger level range selected in step 2.

NOTE *If you select AUTO TIME to set the integration time, the pulse timeout message “LONG INT TRIG NOT DETECTED” will occur if the output is OFF. This message indicates that the integration time has not been updated. To update the integration time, you will have to again select AUTO TIME after the output is turned ON.*

4. Press the DISPLAY key and select the LONG INTEGRATION display type for the desired channel.
5. Observe the long integration readings on the display.

General notes

- Long integration readings will not be taken if the active channel is not the same as the selected channel. For example, if the battery channel (#1) is set to LINT and the active channel is the charger channel (#2) then, long integration readings will not be taken on the battery channel (#1). Therefore, while the charger channel (#2) is active with the LINT function selected on the battery channel (#1), you will not incur the LINT integration time or LINT timeout from the battery channel while waiting for responses from the charger channel (#2). Since no long integration readings are being taken, you will not get any information on whether the pulse is present or not on the battery channel (#1).
- Make sure the voltage and current settings are appropriate for DUT.
- If a pulse timeout occurs (no pulses detected), current will not be measured (i.e. ----A) and the “NO PULSE” message will be displayed. Pulses are not detected with the output OFF. With the output ON, pulses will not be detected if the trigger level is too low or too high. Perform the “Determining correct trigger level (long integration)” procedure on page 4-11 to find an appropriate trigger level.
- While the “NO PULSE” message is displayed, the instrument continues to search for a pulse. The search can be terminated by pressing any front panel key. The “NOT TRIG” message replaces the “NO PULSE” message. To restart the search, press ▲ or ▼ key while displaying long integration readings. The timeout or pulse detection will need to elapse before the display changes.
- To stop taking long integration readings, press any front panel key. As long as the instrument remains in the long integration display state, the measurement process can be resumed by pressing ▲ or ▼ key. While readings are not being taken, the bottom line displays the last valid long integration reading, or dashes if no pulse detected before being stopped.

Determining correct trigger level (long integration)

1. After selecting the appropriate voltage and current values, turn on the output.
2. Select the long integration display type. If the trigger level is too low or too high, the “NO PULSE” message will be displayed. If long integration measurements are instead being displayed, the trigger level is valid. You can skip the rest of this procedure.
3. Go into the main menu (access the main menu in step 3, press the MENU key twice — the first press will stop the readings while the second press accesses the menu.). Select LONG INTEGRAT #1/#2. (Select LONG INTEGRAT #1 for the battery channel and LONG INTEGRAT #2 for the charger channel.)
4. Select and adjust the TRIGGER LEVEL and press ENTER. The unit starts looking for the rising edge of the pulse (this is regardless of the trigger edge setting). If the trigger level is still too low or too high, the “LONG INT TRIG NOT DETECTED” message will be displayed briefly. Note that it may take as long as the timeout value for the message to appear (see “LONG INT TRIG NOT DETECTED message” for more information).

5. If the message appeared, repeat step 4 until a valid trigger level is found.
6. Use the MENU key to back out of the menu structure and display long integration current measurements.

NOTE For the battery channel, make sure the trigger level range setting agrees with the trigger level setting set in Step 4.

LONG INT TRIG NOT DETECTED message

The TRIG NOT DETECTED message is possibly displayed when specific TLEV settings coupled with specific TLEV ranges have been set and a trigger has not been detected. Refer to Table 4-1 for message preconditions.

See step 2 of the “Long integration measurement procedure” on page 4-10 for information on setting the trigger level range. For the charger channel #2, the trigger level range setting is not user selectable.

Table 4-1
TRIG NOT DETECTED message

TLEV setting	TLEV range	TRIG NOT DETECTED Message displayed?
100mA	1A	No (not checked because TLEV setting does not match TLEV range)
1A	1A	May appear
100mA	5A	Yes (TLEV setting too low)
1.1A	5A	No (valid setting)
3A	5A	Yes (TLEV too high)

NOTE Setting the trigger level and/or the trigger range may cause “LONG INT TRIG NOT DETECTED” to appear.

SCPI programming

The commands for long integration measurements are summarized in Table 4-2 (a listing following the table contains specific command notes). “Programming examples” on page 4-19 demonstrate how to use these commands.

Table 4-2
SCPI commands — long integration measurements

Command	Description	Default
:SENSe[1]	SENSe subsystem for channel #1 (battery channel):	
:FUNcTion “LINTegration”	Select long integration measurement function.	VOLT
:LINTegration	Long integration configuration:	
:TIME <NRf>	Set integration time (in sec): X to 60 (where X is 0.850 for 60Hz, or 0.840 for 50Hz).	1
:AUTO	Integration time set automatically.	
:TLEVel <NRf>	Path to set trigger level feature:	
[:AMP] <NRf>	Set trigger level (in amps) for 5A range: 0–5 (5mA resolution).	0.0
:ONE <NRf>	Set trigger level (in amps) for 1A trigger level range: 0–1 (1mA resolution).	0.0
:MILLiamp <NRf>	Set trigger level (in amps) for 100mA range: 0–0.1 (0.1mA resolution).	0.0
:HALFamp <NRf>	Model 2306-PJ only — set trigger level (in amps) for 500mA range: 0-500mA (0.5mA resolution)	0.0
:HUNDred <NRf>	Model 2306-PJ only — set trigger level (in amps) for 100mA range: 0-100mA (0.1mA resolution)	0.0
:TEN <NRf>	Model 2306-PJ only — set trigger level (in amps) for 10mA range: 0-10mA (0.01mA resolution)	0.0
:RANGe <NRf>	Model 2306 or 2306-PJ when on 5A current range. Set trigger level range (100mA, 1A, or 5A). The parameter <NRf> sent with this command causes the trigger to be set with the trigger level setting of MILL, ONE, or AMP. Queries receive responses of 0.1, 1.0, or 5.0 accordingly. In other words, if a value of 2.0A is sent with the command, a value of 5A will be returned as a response to a query.	5A

Command notes (long integration measurements)

SENSe[1]:FUNction 'LINTegration' Applies to battery channel (#1)

SENSe2:FUNction 'LINTegration' Applies to charger channel (#2)

The parameter name can be enclosed in single or double quotes (single — shown above, double — shown in Table 4-2).

**SENSe[1]:LINTegration:SEARch ** Applies to battery channel (#1)

**SENSe2:LINTegration:SEARch ** Applies to charger channel (#2)

Refer to “Using FAST, SEARch, and DETect” for detailed usage information.

**SENSe[1]:LINTegration:FAST ** Applies to battery channel (#1)

**SENSe2:LINTegration:FAST ** Applies to charger channel (#2)

Refer to “Using FAST, SEARch, and DETect” for detailed usage information.

**SENSe[1]:LINTegration:DETect ** Applies to battery channel (#1)

**SENSe2:LINTegration:DETect ** Applies to charger channel (#2)

Refer to “Using FAST, SEARch, and DETect” for detailed usage information.

READ[1]? Applies to battery channel (#1)

READ2? Applies to charger channel (#2)

After sending a trigger reading command to perform long integration measurements, do not address the power supply to talk until all readings are completed. Details on READ? and the other signal oriented measurement commands are provided in Section 9.

Using FAST, SEARch, and DETect

Use FAST, SEARch, and DETect to control how background readings are taken. A background reading is a measurement taken by the power supply between user triggered readings. The selected function dictates how background readings are taken between user triggered readings.

For long integration, a background reading involves looking for the pulse and optionally generating a reading for the user. The various settings of SEARch, FAST and DETect allow the user to fine tune the function. This enables the function to perform the desired background readings (if any) between user triggered readings. The default settings (FAST:OFF, SEARch:ON, and DETect:OFF) allow the long integration background readings to be taken. If no pulse is present, the setting of TimeOUT affects how responsive the supply is to bus commands. If a pulse is present, the search time plus reading time (TIME setting) affects how responsive the supply is to bus commands (refer to Figure 4-3). Table 4-3 on page 4-16 contains the available settings for FAST, SEARch, and DETect commands and a description of the resulting action. For more information on search time, reading time, and TimeOUT, see “Pulse timeout” on page 4-4.

Figure 4-3
TOUT and search time

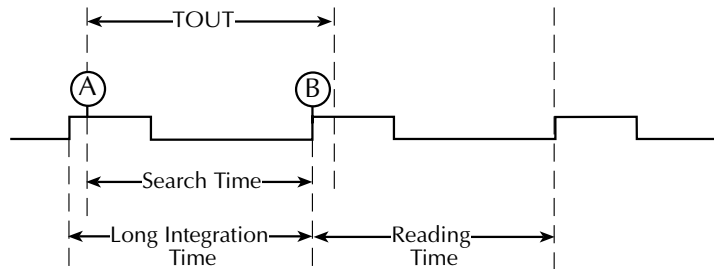

- NOTE**
- If a pulse is not present, timeout needs to elapse (TOUT).
 - If DETECT ON (only), search time needs to elapse before responding to a bus command (reading time not incurred).
 - If SEARCH OFF or FAST ON, search time and reading time not incurred.
 - Search time needs to elapse when checking TLEV command for valid setting.

Table 4-3
FAST, SEARCh, and DETect command reference

FAST	SEARCh	DETEct	Description
ON	ON	ON	<p>The unit is most responsive to bus commands in this mode. The supply does not wait for TOUT or search time plus reading time for background readings and TLEV command checks. Refer to Figure 4-3. Front panel displays “FAST LINT” instead of “LONG INT”.</p> <p>With FAST set to ON, no background long integration measurements occur, no pulse detection between user-triggered readings occur, no checking for the parameter of LINT TLEV commands to detect a pulse occur, no setting of the pulse trigger timeout bits in the status model between user-triggered readings occur.</p> <p>For triggered readings to set the PTT (Pulse Trigger Timeout) bits in the status model, set TEDGe to be RISING or FALLING. If TEDGe is set to NEITHER, the PTT will not be set after the initial setting of FAST to ON and TEDGe to NEITHER. The setting of NEITHER specifies no pulse edge for synchronization or detection. The bit is latched until read so the bit may still be set in the status model from a previous timeout. (See section 7 on the status model for more information.)</p>
ON	ON	OFF	
ON	OFF	ON	
ON	OFF	OFF	

Shaded cells designate command with precedence in each mode.

Table 4-3
FAST, SEARCh, and DETect command reference (cont.)

FAST	SEARCh	DETect	Description
OFF OFF	OFF OFF	ON OFF	<p>The unit is more responsive to bus commands in this mode since the supply does not need to wait for TOUT or search time plus reading time for background readings. However, the supply does need to wait for TOUT or search time when checking the parameter setting for TLEV commands. Refer to Figure 4-3. Front panel displays “NO SEARCH” instead of “LONG INT”.</p> <p>Although no background long integration measurements or pulse detection between user-triggered readings will occur, the checking for the parameter of LINT TLEV commands to detect a pulse will occur. The setting of the pulse trigger timeout bits in the status model will only occur between user-triggered readings if TLEV commands sent. This is regardless of the TEDGe setting since the RISING edge is used for this feature. For triggered readings to set the PTT (Pulse Trigger Timeout) bits in the status model, the TEDGe setting needs to be RISING or FALLING. If TEDGe is set to NEITHER, the PTT will not be set after the initial setting of SEARCh to OFF and TEDGe to NEITHER. The setting of NEITHER specifies no pulse edge for synchronization or detection. The bit is latched until read so the bit may still be set in the status model from a previous timeout. (See section 7 on the Status model for more information.)</p>
OFF	ON	ON	<p>This mode allows the user to know whether the pulse disappeared before a user-triggered reading is requested. The responsiveness of bus commands is governed by LINT TOUT (if no pulses are detected), or by search time (if pulses are detected). Reading time does not have to elapse after detecting the pulse in this mode. Therefore, the longest response time to bus commands is approximately the greater of either TOUT or search time values. Refer to Figure 4-3.</p> <p>With DETect ON, no background long integration measurements will occur between user-triggered readings but pulse detection occurs. If the pulse is detected, the front panel will display "DETECT" on top line of display instead of "LONG INT". If no pulses are detected, the front panel will display "NO DETECT" as well as the PTT (Pulse Trigger Timeout) bit being set in the status model. Since the PTT bit is latched (see section 7 on Status Model), a query for the PTT bit may indicate that pulse trigger timeout occurred although the display is showing DETECT. The checking for the parameter of LINT TLEV commands will occur which may set the PTT bit since looking for a rising edge. This functionality occurs if TEDGe is set to RISING or FALLING.</p> <p>If TEDGe is set to NEITHER, pulse detection will fail since synchronization to an edge for triggering does not occur (there is nothing for the unit to detect). In this mode, the DETECT/NO DETECT on the front panel is not reliable and the setting of the PTT bit of the status model will not happen. Since checking for the parameter of LINT TLEV commands to detect a pulse looks for the RISING edge, this will occur and may set the PTT bit of the status model.</p>

Shaded cells designate command with precedence in each mode.

Table 4-3
FAST, SEARCh, and DETect command reference (cont.)

FAST	SEARCh	DETect	Description
OFF	ON	OFF	<p>With DETect OFF, background long integration measurements will occur between user-triggered readings as well as pulse detection. If the pulse is detected, the front panel will display "LONG INT" on top line of display along with the reading on the bottom line. If no pulses are detected, the front panel will display "NO PULSE" as well as the PTT (Pulse Trigger Timeout) bit being set in the status model. Since the PTT bit is latched (see section 7 on Status Model), a query for the PTT bit may indicate that pulse trigger timeout occurred although the display is displaying LONG INT and a reading. Checking for the parameter of LINT TLEV commands to detect a pulse occurs by looking for a rising edge. This may set the PTT bit. If detecting pulses, the supply's responsiveness to bus commands is affected by search time plus reading time. If not detecting pulses, the supply's responsiveness to bus commands is affected by TOUT. Therefore the longest response time to bus commands is approximately the greater of either TOUT or search time plus reading time (refer Figure 4-3). This functionality occurs if TEDGe is set to RISING or FALLING.</p> <p>If TEDGe is set to NEITHER, pulse detection will fail since synchronization to an edge for triggering does not occur (there is nothing for the unit to detect). In this mode, the front panel will show LONG INT on the top line with a reading on the bottom. The user will have to determine if the pulse was present for the reading or not. In this mode, the PTT bit of the status model will not be set as well and therefore, not useful. Since checking the parameter of LINT TLEV commands to detect a pulse looks for the RISING edge, this may set the PTT bit of the status model if TLEV setting causes no rising edge pulse detection.</p>

Shaded cells designate command with precedence in each mode.

Programming examples

The battery channel programming example applies to the Model 2306 or 2306-PJ on the 5A current range. To modify the example for the 500mA current range (Model 2306-PJ only):

1. Change the SENS:CURR:RANG command line to select the 500mA current range.
2. Change the trigger level commands to appropriate commands for the 500mA current range. In the examples, the command lines requiring this modification are italicized.

The following command sequence will trigger and return one long integration measurement:

Battery channel (#1)

```

DISP:CHAN 1           ` Sets display to battery channel.
SENS:CURR:RANG 5     ` Select 5A range.
VOLT 15              ` Set output voltage to 15V.
CURR 0.75            ` Set current limit to 750mA.
OUTP ON              ` Turn output on.
SENS:LINT:TLEV:RANG 0.5 ` Select 1A trigger level range.
SENS:LINT:TEDG RISING ` Select rising trigger edge to initiate
                        ` measurement.
SENS:LINT:TLEV:ONE 0.1 ` Set trigger level to 100mA for 1A trigger
                        ` level range.
SENS:LINT:TIME:AUTO  ` Set integration time automatically for
                        ` single pulse.
SENS:FUNC "LINT"     ` Select long integration function.
READ?                ` Trigger and return one reading and reading
                        ` shown on display.

```

Charger channel (#2)

```

DISP:CHAN 2           ` Sets display to charger channel.
SENS2:CURR:RANG 5     ` Select 5A range.
SOUR2:VOLT 15         ` Set output voltage to 15V.
SOUR2:CURR 0.75       ` Set current limit to 750mA.
OUTP2 ON              ` Turn output on.
SENS2:LINT:TEDge RISING ` Select rising trigger edge to initiate
                        ` measurement.
SENS2:LINT:TLEV 0.1   ` Set trigger level to 100mA.
SENS2:LINT:TIME:AUTO  ` Set integration time automatically for
                        ` single pulse.
SENS2:FUNC "LINT"     ` Select long integration function.
READ2?                ` Trigger and return one reading and reading
                        ` shown on display

```

5

Relay Control

- **Overview** — Summarizes how the power supply can be used to control an external relay.
- **Connections** — Explains how to connect an external relay circuit to the power supply.
- **Controlling relays** — Explains how to control the external relay circuit.

NOTES *This manual covers Keithley Models 2302, 2302-PJ, 2306, and 2306-PJ simulators (power supplies). Since the Model 2302 and 2302-PJ are single channel battery simulators, functions related to the second channel (i.e., the charger channel) are not available for the Model 2302 and 2302-PJ. Therefore:*

- *battery and charger channel features contained in this manual apply for the Model 2306 and 2306-PJ*
- *only battery channel features contained in this manual apply for the Model 2302 and 2302-PJ*

Refer to Appendix F for specific Model 2302 and 2302-PJ information.

Information contained in this section applies to all power supply channels (unless otherwise noted). In this manual, channel 1 refers to the battery channel while channel 2 refers to the charger channel (2306 and 2306-PJ feature only).

Overview

The power supply can be used to control up to four external relays. The control circuit is made up of four peripheral drivers, a +5VDC source (250mA maximum), a coil diode suppression connection, and a chassis ground return. The drive for the relay may be provided by the supplied +5VDC source or an external DC voltage source.

Figure 5-1 shows the simplified power supply control circuit and a typical configuration to control an external relay driven by an external power source. As shown in the illustration, voltage applied to the power supply must not exceed 24VDC and current for the relay circuit must not exceed 100mA per channel.

Figure 5-2 shows the simplified power supply control circuit and a typical configuration to control an external relay driven by the internal power source. If the supplied +5VDC source is used to drive the external relay, the relay circuit must not exceed 250mA total (100mA per channel).

Note that the coil protection diodes are built in to the power supply driver (the user is not required to add external protection diodes to protect the relay coils).

CAUTION To prevent damage to the power supply that is not covered by the warranty, always make sure to:

- Connect suppression diodes (pin 7) to the appropriate voltage source (the appropriate voltage source will either be an external power source or pin 8 if using the internal source).
- Never exceed the voltage and current limits of the power supply's relay control port:
External Source: 24VDC, 100mA per channel
Internal source:
 - 1) 5VDC, 250mA maximum total current from all channels combined.
 - 2) 100mA per channel maximum (not to exceed the 250mA maximum total current).
- Connect and disconnect relay drive circuits with the power supply power OFF.

Figure 5-1
External source relay control

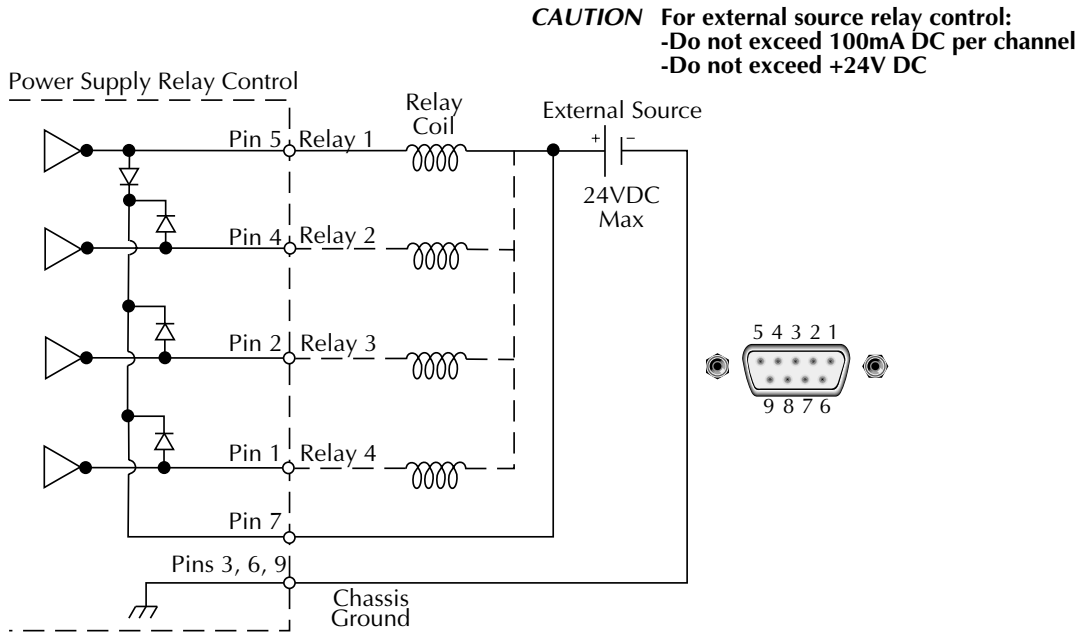
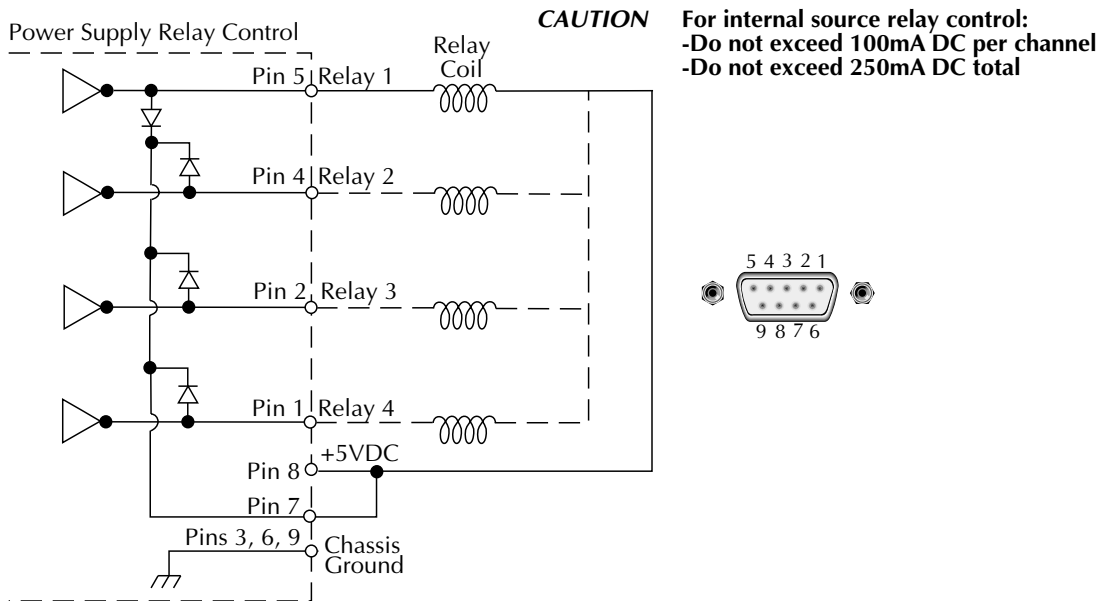

Figure 5-2
Internal source relay control



Connections

An external relay circuit is connected to the power supply via the 9-pin D-SUB connector located on the rear panel. Table 5-1 contains pinouts and connections for this connector. The illustration provides terminal identification for the conductors of the plug.

Figure 5-3
Relay connector (9-pin D-sub)

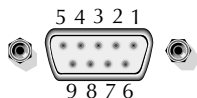

Table 5-1
Relay pinouts (for Figure 5-3)

Pin	Connection
1	Relay 4
2	Relay 3
3	Ground
4	Relay 2
5	Relay 1
6	Ground
7	Suppression diodes
8	+5 VDC
9	Ground

Controlling relays

The external relays (whether powered by the external or internal source) are controlled from the main menu's OUTPUT RELAYS menu item. (The main menu is accessed by pressing the MENU key.) Each of the four output relays can be controlled from this menu.

NOTE Table 1-3 shows the menu structure. Rules to navigate the menu follow the table.

Pressing the ENTER key accepts the current configuration while pressing the MENU key cancels the changes and recalls the previous settings.

Setting a relay (1–4) to a 1 closes the relay control circuit (energizes the relay). A 0 opens the circuit (de-energizes the relay).

1. From the main menu, select OUTPUT RELAYS.

2. Use the ◀ and ▶ arrow keys to move the blinking cursor through the available relays (1: 2: 3: & 4:). Immediately following the relay number and colon is the relay control option. Set the relay control options for each relay to a 1 or 0. Selecting a 1 closes the relay control circuit to energize the relay, while 0 opens the circuit to de-energize the relay.
3. Use the ▲ and ▼ arrow keys to toggle the blinking cursor's value between 1 (close) or zero (open).
4. Repeat steps 2 and 3 to set the relays as desired.
5. Save the changes for all four relays (press the Enter key located on the front panel).

NOTE To cancel changes made, press the MENU key (this sets the instrument back to the last saved changes). (Changes must be cancelled before pressing ENTER.)

All relays open (sample)

```
OUTPUT RELAYS
1:0 2:0 3:0 4:0
```

Relays 1 and 2 closed and 3 and 4 open (sample).

```
OUTPUT RELAYS
1:1 2:1 3:0 4:0
```

SCPI programming

Table 5-2
SCPI command — output relay control

Command	Description	Default
OUTPut[1]	OUTPut subsystem fro Channel #1 (battery channel):	
:RELAy1 <name>	Close (ONE) or open (ZERO) relay control circuit for relay 1.	ZERO
:RELAy2 <name>	Close (ONE) or open (ZERO) relay control circuit for relay 2.	ZERO
:RELAy3 <name>	Close (ONE) or open (ZERO) relay control circuit for relay 3.	ZERO
:RELAy4 <name>	Close (ONE) or open (ZERO) relay control circuit for relay 4.	ZERO

6 GPIB Operation

- **Introduction** — Describes the IEEE-488 (GPIB) standards used by the power supply.
- **GPIB bus connections** — Shows how to connect the power supply to the GPIB.
- **Primary address** — Explains how to check and/or change the primary address for the bus.
- **Setting the GPIB timeout for responses** — Documents general bus commands to set the GPIB timeout.
- **General bus commands** — Documents general bus commands that pertain to all GPIB instruments.
- **Front panel aspects of GPIB operation** — Describes aspects of the front panel and remote panel.
- **Programming syntax** — Provides syntax information for sending command and SCPI commands over the bus.

NOTES *This manual covers Keithley Models 2302, 2302-PJ, 2306, and 2306-PJ simulators (power supplies). Since the Model 2302 and 2302-PJ are single channel battery simulators, functions related to the second channel (i.e., the charger channel) are not available for the Model 2302 and 2302-PJ. Therefore:*

- *battery and charger channel features contained in this manual apply for the Model 2306 and 2306-PJ*
- *only battery channel features contained in this manual apply for the Model 2302 and 2302-PJ*

Refer to Appendix F for specific Model 2302 and 2302-PJ information.

Information contained in this section applies to all power supply channels (unless otherwise noted). In this manual, channel 1 refers to the battery channel while channel 2 refers to the charger channel (2306 and 2306-PJ feature only).

Introduction

The GPIB bus is the IEEE-488 instrumentation data bus with hardware and programming standards originally adopted by the IEEE (Institute of Electrical and Electronic Engineers) in 1975. The power supply conforms to these standards:

- IEEE-488-1987.1
- IEEE-488-1987.2

These standards define a syntax for sending data to and from instruments, how the instrument interprets this data, what registers should exist to record the state of the instrument, and a group of common commands.

- SCPI 1995.0 (Standard Commands for Programmable Instruments)

This standard defines a command language protocol. It goes one step further than IEEE-488-1987.2 and defines a standard set of commands to control every programmable aspect of the instrument.

GPIB bus connections

To connect the power supply to the GPIB bus, use a cable equipped with standard IEEE-488 connectors. The IEEE connector on the power supply is shown in Figure 6-1.

Figure 6-1
IEEE-488 connector

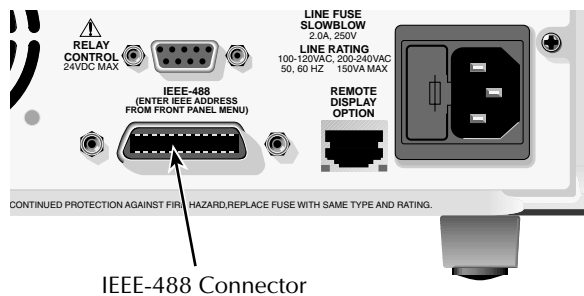

NOTE To minimize interference caused by electromagnetic radiation, use only shielded IEEE-488 cables. Available shielded cables from Keithley are Models 7007-1 and 7007-2.

For a multi-unit test system, you can daisy-chain the instruments to the controller by connecting an IEEE cable from one unit to another. Figure 6-2 shows a typical multi-unit connecting scheme daisy chaining. Although any number of connectors could be stacked on one instrument's GPIB port, avoid possible mechanical damage by not stacking more than three.

Most controllers are equipped with an IEEE-488 style connector, but a few may require a different type of connecting cable. See the controller's instruction manual if it is not equipped with an IEEE-488 style connector.

CAUTION The IEEE-488 connector on the interface accepts metric screws. Do not use early versions of IEEE-488 cables that do not use metric screws to secure connections. On the GPIB cable connectors, metric screws are dark colored while non-metric screws are silver colored.

NOTE Daisy chaining (Figure 6-2) is recommended when installing multi-unit connecting schemes.

Figure 6-2
Daisy chaining

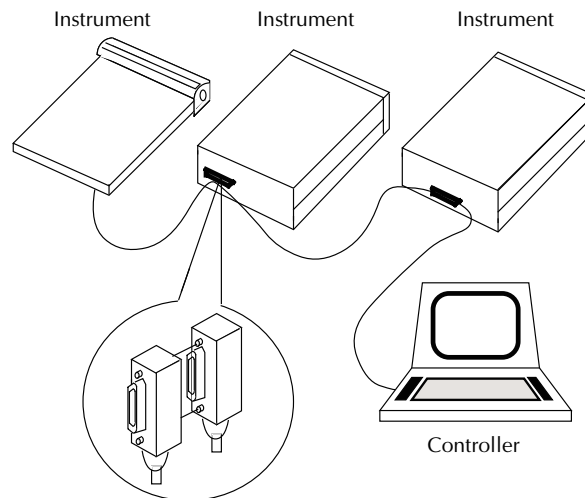

NOTE Observe the following limits concerning the IEEE-488 bus:

- There can be a maximum separation of 4 meters between any two instruments on the bus.
- Make sure the maximum cable length used is the lesser of 20 meters or 2-meters multiplied by the number of devices.
- Limit the number of instruments on the bus to 15 (maximum) with no two instruments having the same address.

Primary address

The power supply ships from the factory with a GPIB address of 16. You can set the address to a value of 0 to 30. Do not assign the same address to another device or to a controller that is on the same GPIB bus.

The GPIB address is checked and/or changed from the menu (which is accessed by pressing the MENU key).

NOTE Table 1-3 shows the menu structure. Rules to navigate the menu follow the table.

Once in the menu, select GPIB ADDRESS. After setting the address value, make sure you press ENTER to select it.

NOTE The present address is displayed on power-up on the top line of the display.

Setting the GPIB timeout for responses

When using GPIB to control the power supply, make sure to set the GPIB timeout for responses. The appropriate setting is dependent on the Model 2306 power supply configuration. The GPIB timeout for responses is the duration the computer waits before timing out after sending a request.

Example

Command	Description
READ?	Requests power supply to trigger a reading for the selected function on the battery channel (channel 1).
<i>Programming language specific</i>	Request power supply talk.

Once the request for the response is made, the “GPIB timeout for responses” activates. “GPIB timeout for responses” is set in milliseconds (1/1000sec).

Long integration readings

When taking long integration readings, make sure to set the timeout value longer than the integration time. For example, if the integration period is 15 seconds, set the “GPIB timeout for responses” > 15000. Setting the “GPIB timeout for responses” greater than the integration time ensures that a GPIB timeout does not occur while the Model 2306 is integrating the reading. The GPIB timeout may need to be set to a value greater than twice the long integration time for cases where the triggered edge was just missed (refer to Figure 4-2).

Pulse current readings

When taking a pulse current low readings with a low time of 500ms and a pulse average of 50, the integration will take 25 seconds. Since the integration period is 25 seconds, set the “GPIB timeout for responses” > 25000. Setting timeout when taking pulse current high and pulse current average readings is similar.

MAV (Message Available Bit)

The MAV is an alternative to setting the GPIB timeout for responses. The MAV is the message available bit of the status register. Enabling the MAV bit causes an SRQ to occur when the instrument has a message to send to the computer.

When using the MAV, two additional commands are required *SRE 16 and the command that waits for SRQ (specific to programming language).

Example

Command	Description
*SRE 16	Sets the MAV bit to enable. This command is required before the sending READ? command.
READ?	Requests power supply to trigger a reading for the selected function on the battery channel (channel 1).
<i>Programming language specific</i>	Wait for SRQ.
<i>Programming language specific</i>	Request power supply to talk.

General bus commands

General bus commands are those commands, such as DCL, that have the same general meaning regardless of the instrument. Table 6-1 lists applicable general bus commands.

Table 6-1
General bus commands

Command	Effect on power supply
REN	Goes into remote when next addressed to listen.
IFC	Reset interface; all devices go into talker and listener idle states.
LLO	Local key locked out.
GTL	Cancel remote; restore front panel operation for the power supply.
DCL	Return all devices to known conditions.
SDC	Returns power supply to known conditions.
GET	Initiates a trigger.
SPE, SPD	Serial polls the power supply.

REN (remote enable)

The remote enable command is sent to the power supply by the controller to set up the instrument for remote operation. Generally, the instrument should be placed in the remote mode before you attempt to program it over the bus. Simply setting REN true does not actually place the instrument in the remote state. You must address the instrument to listen after setting REN true before it goes into remote.

Note that the instrument does not have to be in remote to be a talker.

Also, note that all front panel controls except for LOCAL and POWER are inoperative while the instrument is in remote. You can restore normal front panel operation by pressing the LOCAL key.

IFC (interface clear)

The IFC command is sent by the controller to place all instruments on the bus in the local, talker, listener idle states. The power supply responds to the IFC command by canceling TALK or LSTN mode, if the instrument was previously placed in one of those states. Note that this command does not affect the status of the instrument; settings, data, and event registers are not changed.

To send the IFC command, the controller must set the IFC line true for a minimum of 100 μ s.

LLO (local lockout)

Use the LLO command to prevent local operation of the instrument. After the unit receives LLO, all its front panel controls except POWER are inoperative. In this state, pressing the LOCAL key will not restore control to the front panel. The GTL command restores control to the front panel.

GTL (go to local)

Use the GTL command to put a remote mode instrument into local mode. The GTL command also restores front panel key operation.

DCL (device clear)

Use the DCL command to clear the GPIB interface and return it to a known state. Note that the DCL command is not an addressed command, so all instruments equipped to implement DCL will do so simultaneously.

When the power supply receives a DCL command, it clears the input buffer and output queue, cancels deferred commands, and clears any command that prevents the processing of any other device command. A DCL does not affect instrument settings and stored data.

SDC (selective device clear)

The SDC command is an addressed command that performs essentially the same function as the DCL command. However, since each device must be individually addressed, the SDC command provides a method to clear only selected instruments instead of clearing all instruments simultaneously, as is the case with DCL.

GET (group execute trigger)

GET is a GPIB trigger that is used as an event to control operation. The power supply reacts to this trigger if it is the programmed control source.

SPE, SPD (serial polling)

Use the serial polling sequence to obtain the power supply serial poll byte. The serial poll byte contains important information about internal functions. Generally, the serial polling sequence is used by the controller to determine which of several instruments has requested service with the SRQ line. However, the serial polling sequence may be performed at any time to obtain the status byte from the power supply.

Front panel aspects of GPIB operation

The following paragraphs describe aspects of the front panel and remote panel that are part of GPIB operation, including the remote operation indicator, LOCAL key, and messages.

Remote indicator and LOCAL key

When the power supply is in the remote state, the “R” character is displayed in the bottom right corner of the display. It blinks as a solid block character. “R” does not necessarily indicate the state of the REM line, as the instrument must be addressed to listen with REM true before the “R” indicator turns on.

When the instrument is in remote, all front panel keys, except for the LOCAL key, are locked out. The LOCAL key cancels the remote state and restores local operation of the instrument. Pressing the LOCAL key also turns off the “R” indicator and returns the display to normal if a user-defined message was displayed.

If the LLO (local lockout) command is in effect, the LOCAL key is also inoperative.

Error and status messages

See Appendix B for a list of error and status messages associated with IEEE-488 programming. The instrument can be programmed to generate an SRQ, and command queries can be performed to check for specific error conditions.

Programming syntax

The information in the following paragraphs covers syntax for both common commands and SCPI commands. For information not covered here, refer to Section 8 for common commands or to Section 11 for SCPI commands. Also refer the IEEE-488.2 and SCPI standards.

Command words

Program messages are made up of one or more command words and parameters.

Commands and command parameters

Common commands and SCPI commands may or may not use a parameter. The following are some examples:

*SAV <NRf>	Parameter (NRf) required
*RST	No parameter used
:DISPlay:TEXT:STATe 	Parameter required
:STATus:PRESet	No parameter used.

Put at least one space between the command word and the parameter.

Brackets [] — Some command words are enclosed in brackets ([]). These brackets are used to denote an optional command word that does not need to be included in the program message. For example:

```
:FORMat[:DATA]?
```

These brackets indicate that :DATA is implied (optional) and does not have to be used. Thus, the above command can be sent as :FORMat? or :FORMat:DATA?.

Notice that the optional command is used without the brackets. When using optional command words in your program, do not include the brackets.

Parameter types — The following are some of the more common parameter types:

- Boolean — Used to enable or disable an instrument operation. 0 or OFF disables the operation, and 1 or ON enables the operation. Example:
:DISPlay:TEXT:STATe ON Enable text message mode of display.
- <name> Name parameter — Select a parameter name from a listed group. Example:

```
<name> = LIMit
        = TRIP
```

:CURRent:LIMit:TYPE TRIP — Turn output off when current limit reached on battery channel (#1).

Case sensitivity

Common commands and SCPI commands are not case sensitive. You can use upper or lower case and any case combination. Examples:

*RST	= *rst
:DATA?	= :data?
:STATus:PRESet	= :status:preset

Long-form and short-form versions

A SCPI command word can be sent in its long-form or short-form version. The command subsystem tables in Section 11 provide the long-form version. However, the short-form version is indicated by upper case characters. Examples:

:STATus:PRESet	long-form
:STAT:PRES	short-form
:STATu:PRES	long-form and short-form combination

Note that each command word must be in either long-form or short-form. For example,

:STATu:PRESe is illegal and will generate an error. The command will not be executed.

Short-form rules

Use the following rules to determine the short-form version of any SCPI command or parameter:

- If the length of the word is four letters or less, no short form version exists. Example:
:auto = :auto

These rules apply to words that exceed four letters:

- If the fourth letter of the word is a vowel, delete it and all the letters after it. Example:
:dvmeter = :dvm
- If the fourth letter of the command word is a consonant, retain it but drop all the letters after it. Example:
:format = :form
- If the command contains a question mark (; query) or a non-optional number included in the command word, you must include it in the short-form version. Example:
:function? = :func?
:SOURce2 = :SOUR2
- Command words or characters that are enclosed in brackets ([]) are optional and need not be included in the program message.

Program messages

A program message is made up of one or more command words sent by the computer to the instrument. Each common command is a three letter acronym preceded by an asterisk (*). SCPI commands are categorized in the subsystem. For example, :STATus subsystem will be used to help explain how command words are structured to formulate program messages.

:STATus	Path (Root)
:OPERation	Path
:ENABle <NRf>	Command and parameter
:ENABle?	Query command
:PRESet	Command

Single command messages

The previous command structure has three levels. The first level is made up of the root command (:STATus) and serves as a path. The second level is made up of another path (:OPERation) and a command (:PRESet). The third path is made up of one command for the :OPERation path. The three commands in this structure can be executed by sending three separate program messages as follows:

```
:stat:oper:enab <NRf>
:stat:oper:enab?
:stat:pres
```

In each of the above program messages, the path pointer starts at the root command (:stat) and moves down the command levels until the command is executed.

Multiple command messages

You can send multiple command messages in the same program message as long as they are separated by semicolons (;). Here is an example showing two commands in one program message:

```
:stat:pres; :stat:oper:enab <NRf>
```

When this command is sent, the first command word is recognized as the root command (:stat). When the next colon is detected, the path pointer moves down to the next command level and executes the command. When the path pointer sees the colon after the semicolon (;), it resets back to the root level and starts over.

Commands that are on the same command level can be executed without having to retype the entire command path. Example:

```
:stat:oper:enab <NRf>; enab?
```

After the first command (:enab) is executed, the path pointer is at the third command level in the structure. Since :enab? is also on the third level, it can be typed in without repeating the entire path name. Notice that the leading colon for :enab? is not included in the program message. If a colon were included, the path pointer would reset to the root level and expect a root command. Since :enab? is not a root command, an error would occur.

Command path rules

- Each new program message must begin with the root command, unless it is optional (e.g., [:SOURCE1]). If the root is optional, treat a command word on the next level as the root.
- The colon (:) at the beginning of a program message is optional and need not be used. Example:
:stat:pres = stat:pres
- When the path pointer detects a colon (:), it moves down to the next command level. An exception is when the path pointer detects a semicolon (;), which is used to separate commands within the program message (see next rule).
- When the path pointer detects a colon (:) that immediately follows a semicolon (;), it resets back to the root level.
- The path pointer can only move down; it cannot be moved up a level. Executing a command at a higher level requires that you start over at the root command.

Using common and SCPI commands in the same message

Both common commands and SCPI commands can be used in the same message as long as they are separated by semicolons (;). A common command can be executed at any command level and will not affect the path pointer. Example:

```
:stat:oper:enab <NRf>; *ESE <NRf>
```

Program message terminator (PMT)

Each program message must be terminated with an LF (line feed), EOI (end or identify), or an LF+EOI. The bus will hang if your computer does not provide this termination. The following example shows how a program message must be terminated:

```
:outp on <PMT>
```

Command execution rules

- Commands execute in the order that they are presented in the program message.
- An invalid command generates an error and is not executed.
- Valid commands that precede an invalid command in a multiple command program message are executed.
- Valid commands that follow an invalid command in a multiple command program message are ignored.

Response messages

A response message is the message sent by the instrument to the computer in response to a query command program message.

Sending a response message

After sending a query command, the response message is placed in the output queue. When the power supply is then addressed to talk, the response message is sent from the output queue to the computer.

Multiple response messages

If you send more than one query command in the same program message (see “Multiple command messages”), the multiple response messages for all the queries are sent to the computer when the power supply is addressed to talk. The responses are sent in the order the query commands were sent and are separated by semicolons (;). Items within the same query are separated by commas (.). The following example shows the response message for a program message that contains four single item query commands:

```
0; 1; 1; 0
```

Response message terminator (RMT)

Each response is terminated with an LF (line feed) and EOI (end or identify). The following example shows how a multiple response message is terminated:

```
0; 1; 1; 0; <RMT>
```

Message exchange protocol

Two rules summarize the message exchange protocol:

Rule 1: You must always tell the power supply what to send to the computer.

The following two steps must always be performed to send information from the instrument to the computer:

1. Send the appropriate query command(s) in a program message.
2. Address the power supply to talk.

Rule 2: The complete response message must be received by the computer before another program message can be sent to the power supply.

7

Status Structure

- **Overview** — Provides an operational overview of the status structure for the power supply.
- **Clearing registers and queues** — Covers the actions that clear (reset) registers and queues.
- **Programming and reading registers** — Explains how to program enable registers and read any register in the status structure.
- **Status byte and service request (SRQ)** — Explains how to program the status byte to generate service requests (SRQs). Shows how to use the serial poll sequence to detect SRQs.
- **Status register sets** — Provides bit identification and command information for the four status register sets; standard event status, operation event status, measurement event status and questionable event status.
- **Queues** — Provides details and command information on the output queue and error queue.

NOTES *This manual covers Keithley Models 2302, 2302-PJ, 2306, and 2306-PJ simulators (power supplies). Since the Model 2302 and 2302-PJ are single channel battery simulators, functions related to the second channel (i.e., the charger channel) are not available for the Model 2302 and 2302-PJ. Therefore:*

- *battery and charger channel features contained in this manual apply for the Model 2306 and 2306-PJ*
- *only battery channel features contained in this manual apply for the Model 2302 and 2302-PJ*

Refer to Appendix F for specific Model 2302 and 2302-PJ information.

Information contained in this section applies to all power supply channels (unless otherwise noted). In this manual, channel 1 refers to the battery channel while channel 2 refers to the charger channel (2306 and 2306-PJ feature only).

Overview

The power supply provides a series of status registers and queues allowing the operator to monitor and manipulate the various instrument events. The status structure is shown in Figure 7-1. The heart of the status structure is the status byte register. This register can be read by the user's test program to determine if a service request (SRQ) has occurred, and what event caused it.

Status byte and SRQ

The status byte register receives the summary bits of four status register sets and two queues. The register sets and queues monitor the various instrument events. When an enabled event occurs, it sets a summary bit in the status byte register. When a summary bit of the status byte is set and its corresponding enable bit is set (as programmed by the user), the RQS/MSS bit will set to indicate that an SRQ has occurred.

Status register sets

A typical status register set is made up of a condition register, an event register and an event enable register. A condition register is a read-only register that constantly updates to reflect the present operating conditions of the instrument.

When an event occurs, the appropriate event register bit sets to 1. The bit remains latched to 1 until the register is reset. When an event register bit is set and its corresponding enable bit is set (as programmed by the user), the output (summary) of the register will set to 1, which in turn sets the summary bit of the status byte register.

Queues

The power supply uses an output queue and an error queue. The response messages to query commands are placed in the output queue. As various programming errors and status messages occur, they are placed in the error queue. When a queue contains data, it sets the appropriate summary bit of the status byte register.

Figure 7-1
Status model structure

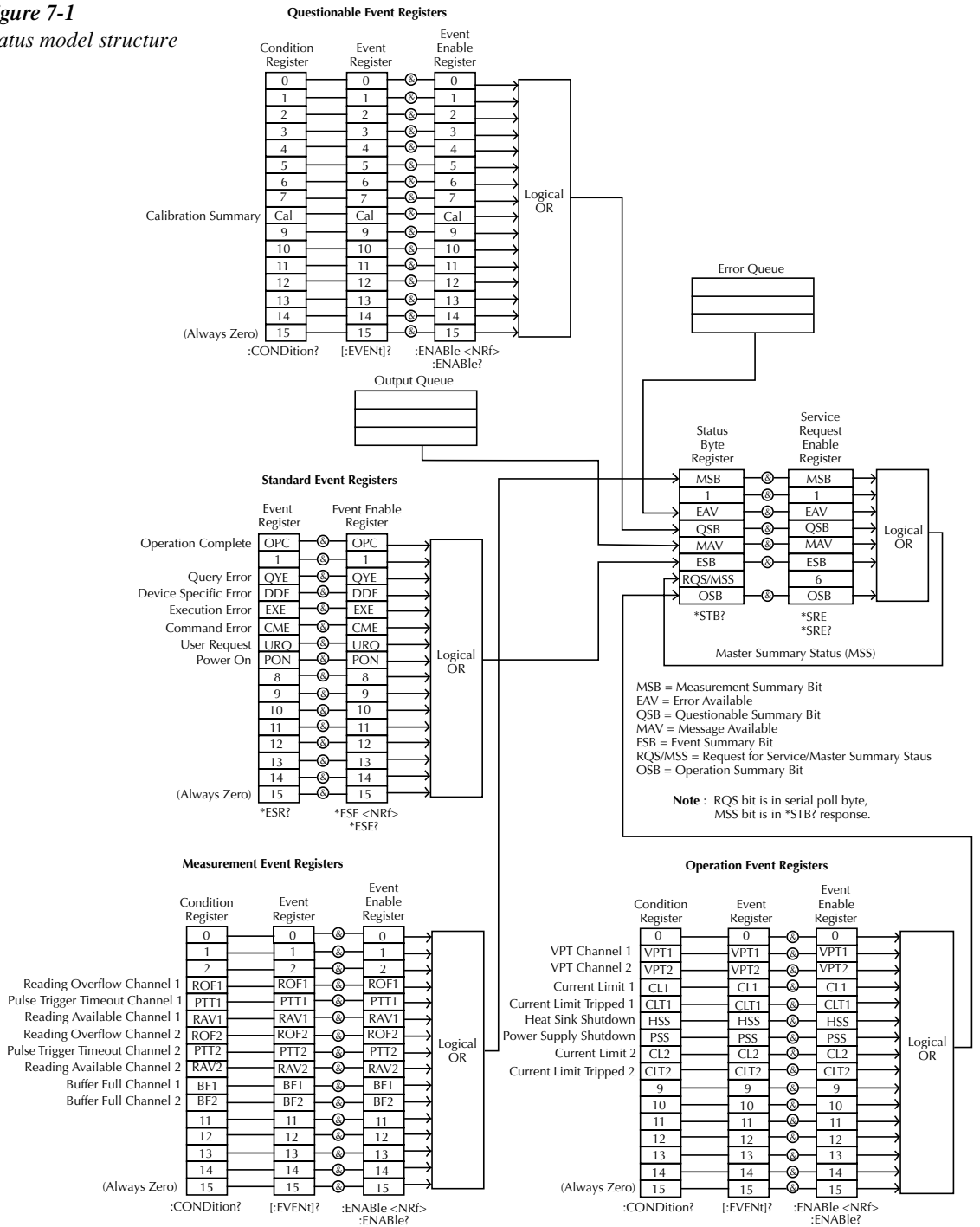

Clearing registers and queues

When the power supply is turned on, the bits of all registers in the status structure are clear (reset to 0) and the two queues are empty. Commands to reset the event and event enable registers, and the error queue are listed in Table 7-1. In addition to these commands, any enable register can be reset by sending the 0 parameter value with the individual command to program the register.

NOTE *RST has no effect on status structure registers and queues. See “Queues” on page 7-19 for details on the error queue.

Table 7-1
Common and SCPI commands — reset registers and clear queues

Commands	Description	Ref
To reset registers: *CLS	Reset all bits of the following event registers to 0: Standard event register Operation event register Measurement event register Questionable event register	
STATus :PRESet	STATus subsystem: Reset all bits of the following enable registers to 0: Operation event enable register Measurement event enable register Questionable event enable register	Note 1
To clear error queue: *CLS	Clear all messages from error queue	Note 2
STATus :QUEue {:NEXT}? :CLEar	STATus subsystem: Error queue: Read and clear the oldest error/status message. Clear all messages from error queue.	Note 3
SYSTEM :ERRor? :CLEar	SYSTEM subsystem: Read and clear the oldest error/status message. Clear all messages from error queue.	Note 3

Notes:

1. The standard event enable register is not reset by STATus:PRESet or *CLS. Send the 0 parameter value with *ESE to reset all bits of that enable register to 0 (see “Status byte and service request commands” on page 7-9 for service request enable register).
2. STATus:PRESet has no effect on the error queue.
3. Use either of the two :CLEar commands to clear the error queue.

Programming and reading registers

Programming enable registers

The enable registers can be programmed by the user. All other registers in the status structure are read-only registers. The following explains how to ascertain the parameter value for the various commands used to program enable registers. The actual commands are covered later in this section (refer to Table 7-1 and Table 7-5).

A command to program an event enable register is sent with a decimal parameter value that determines the desired state (0 or 1) of each bit in the appropriate register. The bit positions of the register (Figure 7-2) indicate the parameter value in binary format. For example, if you wish to set bits B4, B3 and B1, the binary value would be 11010 (where B4=1, B3=1, B2=0, B1=1, B0=0 and all other bits are 0). The decimal equivalent of binary 11010 is 26. Therefore, the parameter value for the enable command is 26.

Another way to determine the decimal value is to add up the decimal weights for the bits that you wish to set. Note that Figure 7-2 includes the decimal weight for each register bit. To set bits B4, B3 and B1, the parameter value would be the sum of the decimal weights for those bits ($16+8+2 = 26$).

Figure 7-2
16-bit status register

A) Bits 0 through 7

Bit Position	B7	B6	B5	B4	B3	B2	B1	B0
Binary Value	0/1	0/1	0/1	0/1	0/1	0/1	0/1	0/1
Decimal Weights	128 (2^7)	64 (2^6)	32 (2^5)	16 (2^4)	8 (2^3)	4 (2^2)	2 (2^1)	1 (2^0)

B) Bits 8 through 15

Bit Position	B15	B14	B13	B12	B11	B10	B9	B8
Binary Value	0/1	0/1	0/1	0/1	0/1	0/1	0/1	0/1
Decimal Weights	32768 (2^{15})	16384 (2^{14})	8192 (2^{13})	4096 (2^{12})	2048 (2^{11})	1024 (2^{10})	512 (2^9)	256 (2^8)

Reading registers

Any register in the status structure can be read by using the appropriate query (?) command. The specific query commands are covered later in this section (refer to Table 7-2 through Table 7-5).

The response message to the query command is a decimal value. To determine which bits in the register are set, convert that decimal value to its binary equivalent. For example, the binary equivalent of decimal 41 is 101001. This binary value indicates that bits B5, B3 and B0 are set.

Status byte and service request (SRQ)

Service request is controlled by two 8-bit registers; the status byte register and the service request enable register. Figure 7-3 shows the structure of these registers.

Figure 7-3
Status byte and service request

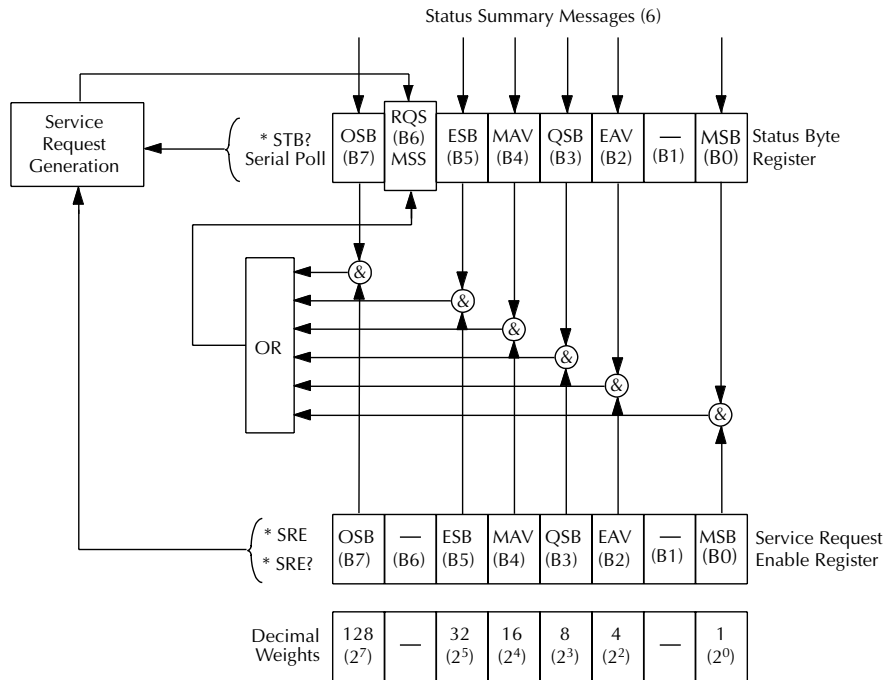

- OSB = Operation Summary Bit
- MSS = Master Summary Status
- RQS = Request for Service
- ESB = Event Summary Bit
- MAV = Message Available
- QSB = Questionable Summary Bit
- EAV = Error Available
- MSB = Measurement Summary Bit
- & = Logical AND
- OR = Logical OR

Status byte register

The summary messages from the status registers and queues are used to set or clear the appropriate bits (B0, B2, B3, B4, B5, and B7) of the status byte register. These summary bits do not latch, and their states (0 or 1) are solely dependent on the summary messages (0 or 1). For example, if the standard event register is read, its register will clear. As a result, its summary message will reset to 0, which in turn will reset the ESB bit in the status byte register.

The bits of the status byte register are described as follows:

- **Bit B0, measurement status (MSB)** — Set summary bit indicates that an enabled measurement event has occurred.
- **Bit B1** — Not used.
- **Bit B2, error available (EAV)** — Set summary bit indicates that an error or status message is present in the error queue.
- **Bit B3, questionable summary bit (QSB)** — Set summary bit indicates that an enabled questionable event has occurred.
- **Bit B4, message available (MAV)** — Set summary bit indicates that a response message is present in the output queue.
- **Bit B5, event summary bit (ESB)** — Set summary bit indicates that an enabled standard event has occurred.
- **Bit B6, request service (RQS)/master summary status (MSS)** — Set bit indicates that an enabled summary bit of the status byte register is set.
- **Bit B7, operation summary (OSB)** — Set summary bit indicates that an enabled operation event has occurred.

Depending on how it is used, bit B6 of the status byte register is either the request for service (RQS) bit or the master summary status (MSS) bit:

- When using the serial poll sequence of the power supply to obtain the status byte (a.k.a. serial poll byte), B6 is the RQS bit. See “Serial Polling and SRQ” for details on using the serial poll sequence.
- When using the *STB? command (see “Status byte and service request commands” on page 7-9) to read the status byte, B6 is the MSS bit.

Service request enable register

The generation of a service request is controlled by the service request enable register. This register is programmed by the user and is used to enable or disable the setting of bit B6 (RQS/MSS) by the status summary message bits (B0, B2, B3, B4, B5, and B7) of the status byte register. As shown in Figure 7-3, the summary bits are logically ANDed (&) with the corresponding enable bits of the service request enable register. When a set (1) summary bit is ANDed with an enabled (1) bit of the enable register, the logic “1” output is applied to the input of the OR gate and, therefore, sets the MSS/RQS bit (B6) in the status byte register.

The individual bits of the service request enable register can be set or cleared by using the *SRE common command. To read the service request enable register, use the *SRE? query command. The service request enable register clears when power is cycled or a parameter value of 0 is sent with the *SRE command (i.e. *SRE 0). The commands to program and read the SRQ enable register are listed in Table 7-2.

Serial polling and SRQ

Any enabled event summary bit that goes from 0 to 1 will set bit B6 and generate an SRQ (service request). In your test program, you can periodically read the status byte to check if an SRQ has occurred and what caused it. If an SRQ occurs, the program can, for example, branch to an appropriate subroutine that will service the request.

Typically, SRQs are managed by the serial poll sequence of the power supply. If an SRQ does not occur, bit B6 (RQS) of the status byte register will remain cleared, and the program will simply proceed normally after the serial poll is performed. If an SRQ does occur, bit B6 of the status byte register will set, and the program can branch to a service subroutine when the SRQ is detected by the serial poll.

The serial poll automatically resets RQS of the status byte register. This allows subsequent serial polls to monitor bit B6 for an SRQ occurrence generated by other event types. After a serial poll, the same event can cause another SRQ, even if the event register that caused the first SRQ has not been cleared.

The serial poll does not clear MSS. The MSS bit stays set until all status byte summary bits are reset.

SPE, SPD (serial polling)

The SPE, SPD general bus command is used to serial poll the power supply. Serial polling obtains the serial poll byte (status byte). Typically, serial polling is used by the controller to determine which of several instruments has requested service with the SRQ line.

Status byte and service request commands

The commands to program and read the status byte register and service request enable register are listed in Table 7-2. For details on programming and reading registers, see “Programming enable registers” and “Reading registers” on page 7-5.

NOTE To reset the bits of the service request enable register to 0, use 0 as the parameter value for the *SRE command (i.e. *SRE 0).

Table 7-2
Command commands — status byte and service request enable registers

Command	Description	Default
*STB?	Read status byte register	(Note)
*SRE <NRf>	Program the service request enable register: 0 to 255	
*SRE?	Read the service request enable register	

Note: *CLS and STATus:PRESet have no effect on the service request enable register.

Programming example — read status byte

The following command sequence enables EAV (error available), sends an invalid command, and then reads the status byte register:

```
*CLS           ` Clear Status Byte Register.
*SRE 4        ` Enable EAV.
BAD:COMMAND  ` Send an invalid command to generate an error.
*STB?        ` Read status byte. The value 68 will be returned to indicate
              ` that bits B2 (EAV) and B6 (MSS) of the Status Byte Register
              ` are set.
```

Status register sets

As shown in Figure 7-1, there are four status register sets in the status structure of the power supply: standard event status, operation event status, measurement event status and questionable event status.

Register bit descriptions

Standard event status

The used bits of the standard event register (shown in Figure 7-4) are described as follows:

- **Bit B0, operation complete (OPC)** — Set bit indicates that all pending selected device operations are completed and the power supply is ready to accept new commands. This bit only sets in response to the *OPC command. See Section 8 for details on *OPC.
- **Bit B2, query error (QYE)** — Set bit indicates that you attempted to read data from an empty output queue.
- **Bit B3, device-dependent error (DDE)** — Set bit indicates that an instrument operation did not execute properly due to some internal condition.
- **Bit B4, execution error (EXE)** — Set bit indicates that the power supply detected an error while trying to execute a command.
- **Bit B5, command error (CME)** — Set bit indicates that a command error has occurred. Command errors include:
 - IEEE-488.2 syntax error — power supply received a message that does not follow the defined syntax of the IEEE-488.2 standard.
 - Semantic error — power supply received a command that was misspelled or received an optional IEEE-488.2 command that is not implemented.
 - The instrument received a group execute trigger (GET) inside a program message.
- **Bit B6, user request (URQ)** — Set bit indicates that the LOCAL key on the power supply front panel was pressed.
- **Bit B7, power ON (PON)** — Set bit indicates that the power supply has been turned off and turned back on since the last time this register has been read.

Operation event status

The used bits of the operation event register (shown in Figure 7-5) are described as follows:

- **Bit B1, voltage protection channel #1 (VPT1)** — Set bit indicates that the battery channel (#1) is in voltage protection mode. In this mode, the output has been turned off and the front panel displays “VPT”. (Battery channel only — for the charger channel, see Bit 2.)
- **Bit B2, voltage protection channel #2 (VPT2)** — Set bit indicates that the charger channel (#2) is in voltage protection mode. In this mode, the output has been turned off and the front panel displays “VPT”. (Charger channel only — for the battery channel, see Bit 1.)
- **Bit B3, current limit #1 (CL1)** — Set bit indicates that the battery channel’s (#1) output is in current limit. This bit clears when the instrument is no longer in current limit. (Battery channel only — for the charger channel, see Bit 7.)
- **Bit B4, current limit tripped #1 (CLT1)** — Set bit indicates that the battery channel’s (#1) output has turned off due to a current limit trip condition. This bit clears when the output is turned back on. (Battery channel only — for the charger channel, see Bit 8.)
- **Bit B5, heat sink shutdown (HSS)** — This bit indicates that the output has turned off due to the output stage heat sink overheating.
- **Bit B6, power supply shutdown (PSS)** — This bit indicates that the output has turned off due to the main AC/DC power supply heat sink overheating.
- **Bit B7, current limit #2 (CL2)** — Set bit indicates that the charger channel’s (#2) output is in current limit. This bit clears when the instrument is no longer in current limit. (Charger channel only—for the battery channel, see Bit 3.)
- **Bit B8, current limit tripped #2 (CLT2)** — Set bit indicates that the charger channel’s (#2) output has turned off due to a current limit trip condition. This bit clears when the output is turned back on (charger channel only — for the battery channel, see Bit 4).

Figure 7-5
Operation event status

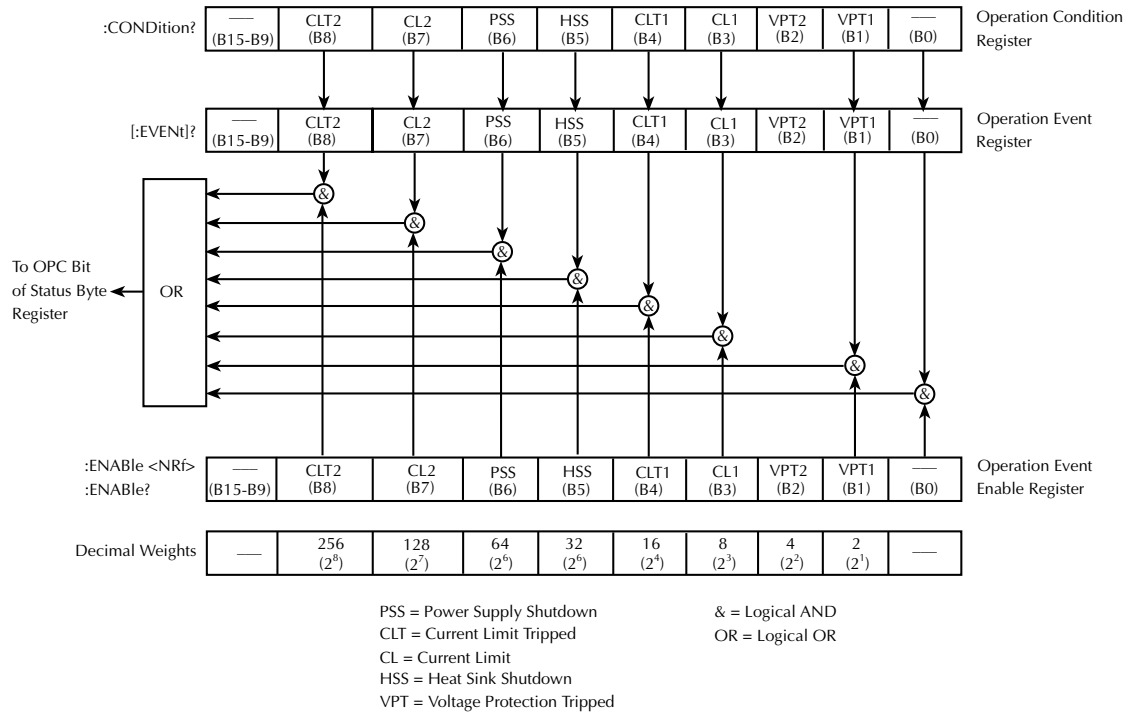

Measurement event status

The used bits of the measurement event register (shown in Figure 7-6) are described as follows:

- **Bit B3, reading overflow #1 (ROF1)** — Set bit indicates that the battery channel's (#1) reading exceeds the measurement range of the instrument. (Battery channel only — for the charger channel, see Bit 6.)
- **Bit B4, pulse trigger timeout #1 (PTT1)** — Set bit indicates that a battery channel (#1) current pulse has not been detected. This bit applies to pulse current and long integration functionality. (Battery channel only — for the charger channel, see Bit 7.)
- **Bit B5, reading available #1 (RAV1)** — Set bit indicates that a battery channel (#1) reading was taken and processed. (Battery channel only — for the charger channel, see Bit 8.)
- **Bit B6, reading overflow #2 (ROF2)** — Set bit indicates that the charger channel's (#2) reading exceeds the measurement range of the instrument. (Charger channel only — for the battery channel, see Bit 3.)
- **Bit B7, pulse trigger timeout #2 (PTT2)** — Set bit indicates that a charger channel (#2) current pulse has not been detected. This bit applies to pulse current and long integration functionality. (Charger channel only — for the battery channel, see Bit 4.)
- **Bit B8, reading available #2 (RAV2)** — Set bit indicates that a charger channel (#2) reading was taken and processed. (Charger channel only — for the battery channel, see Bit 5.)
- **Bit B9, buffer full #1 (BF1)** — Set bit indicates that the specified number of battery channel's (#1) readings (average count) have been taken. (Battery channel only — for the charger channel, see Bit 10.)
- **Bit B10, buffer full #2 (BF2)** — Set bit indicates that the specified number of charger channel's (#2) readings (average count) have been taken. (Charger channel only — for the battery channel, see Bit 9.)

Questionable event status

The used bit of the questionable event register (shown in Figure 7-7) is described as follows:

- **Bit B8, calibration summary (Cal)** — Set bit indicates that an invalid calibration constant was detected during the power-up sequence. This error will clear after successful calibration of the power supply.

Figure 7-7
Questionable event status

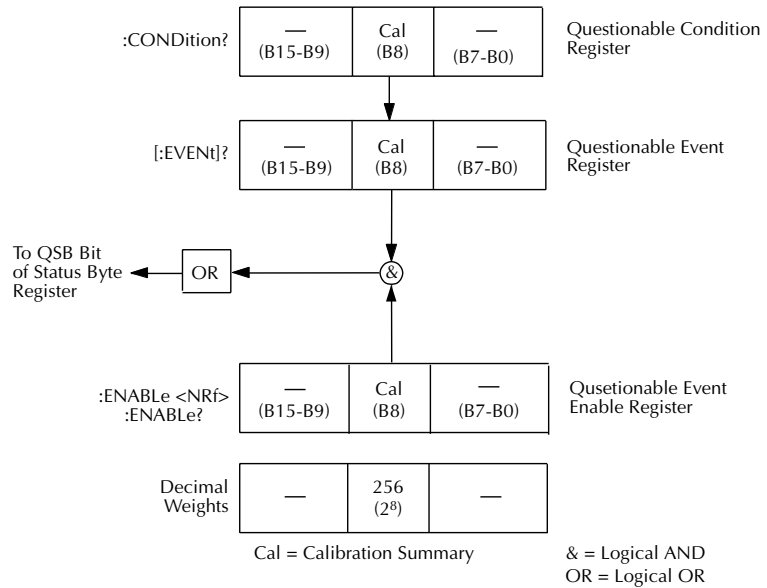

Condition registers

As Figure 7-1 shows, each status register set (except the standard event register set) has a condition register. A condition register is a real-time, read-only register that constantly updates to reflect the present operating conditions of the instrument. For example, when a current pulse is not detected on the battery channel, bit B4 (PTT1) of the measurement condition register will be set (1). When the pulse is detected, the bit clears (0).

The commands to read the condition registers are listed in Table 7-3. For details on reading registers, See “Reading registers” on page 7-5.

Table 7-3
Common and SCPI commands — condition registers

Command	Description
STATus :OPERation:CONDition? :MEASurement:CONDition? :QUESTionable:CONDition?	STATus subsystem: Read operation condition register. Read measurement condition register. Read questionable condition register.

Event registers

As Figure 7-1 shows, each status register set has an event register. When an event occurs, the appropriate event register bit sets to 1. The bit remains latched to 1 until the register is reset. Reading an event register clears the bits of that register. *CLS resets all four event registers.

The commands to read the event registers are listed in Table 7-4. For details on reading registers, see “Reading registers” on page 7-5.

Table 7-4
Common and SCPI commands — event registers

Command	Description	Default
*ESR?	Read standard event status register.	(Note)
STATus :OPERation[:EVENT]? :MEASurement[:EVENT]? :QUESTionable[:EVENT]?	STATus subsystem: Read operation event register. Read measurement event register. Read questionable event register.	

Note: Power-up and *CLS resets all bits of all event registers to 0. STATus:PRESet has no effect.

Event enable registers

As Figure 7-1 shows, each status register set has an enable register. Each event register bit is logically ANDed (&) to a corresponding enable bit of an enable register. Therefore, when an event bit is set and the corresponding enable bit is set (as programmed by the user), the output (summary) of the register will set to 1, which in turn sets the summary bit of the status byte register.

The commands to program and read the event enable registers are listed in Table 7-5. For details on programming and reading registers, see “Programming enable registers” and “Reading registers” on page 7-5.

NOTE The bits of any enable register can be reset to 0 by sending the 0 parameter value with the appropriate enable command (i.e. `STATUS:OPERation:ENABLE 0`).

Table 7-5
Common and SCPI commands — event enable registers

Command	Description	Default
*ESE <NRf> *ESE?	Program standard event enable register (see “Parameters”). Read standard event enable register.	(Note)
STATus :OPERation :ENABLE <NRf> :ENABLE? :MEASurement :ENABLE <NRf> :ENABLE? :QUESTionable :ENABLE <NRf> :ENABLE?	STATus subsystem: Operation event enable register: Program enable register (see “Parameters”). Read enable register. Measurement event enable register: Program enable register (see “Parameters”). Read enable register. Questionable event enable register: Program enable register (see “Parameters”). Read enable register:	
Parameters: <NRf> = 0 to 65535 Decimal format		

Note: Power-up and `STATus:PRESet` resets all bits of all enable registers to 0. `*CLS` has no effect. `STATus:PRESet` has no effect on settings for `*ESE`.

Programming example — program and read measurement event register

The following command sequence enables the battery channel (#1) buffer full bit (B9) of the measurement register set, and then reads the event register. After the programmed number of readings (average count) have been taken, reading the event register will return a value that has bit 9 set (bit 9 has a decimal value of 512).

```

STAT:MEAS:ENAB 512      ` Enable BF1 (Buffer Full for battery channel).
*TRG                   ` Trigger buffer data.
STAT:MEAS?             ` Read Measurement Event Register.
                        ` Once STAT:MEAS? returns a value that has bit 9
                        ` (bit 9 has a decimal value of 512) set,
                        ` you may talk the instrument for the data.
FETCh:ARR?            ` Request the buffer data from the 2306
Language specific     ` Talk the 2306 for the array (buffer) data.

```

This slows down the responsiveness of the Model 2306 since while the unit is trying to fill the buffer it has to respond to the STAT:MEAS? to let you know if the buffer is full. Once the buffer is full, it may be talked for the array of data as shown in the example. If the Model 2306 is talked too early for the buffer data, then a GPIB timeout may occur. (See “Setting the GPIB timeout for Responses” in Section 6.)

The following command sequence enables the battery channel’s (#1) buffer full bit (B9) of the measurement register set, and then causes an SRQ when the buffer is full:

```

STAT:MEAS:ENAB 512      ` Enable BF1 (Buffer Full for battery channel).
*SRE 1                  ` Enable MSB bit of status byte.
READ:ARR?              ` Trigger buffer data.
Language specific      ` Wait for an SRQ on BF1.
Language specific      ` Talk the 2306 for the array (buffer) data.

```

This method prevents the Model 2306 from being talked too early for data. In addition, this eliminates the concern of knowing the GPIB timeout setting. (See “Setting the GPIB timeout for Responses” in Section 6.)

Queues

The power supply uses two queues, which are first-in, first-out (FIFO) registers:

- Output queue — Used to hold reading and response messages.
- Error queue — Used to hold error and status messages.

The power supply status model (Figure 7-1) shows how the two queues are structured with the other registers.

Output queue

The output queue holds data that pertains to the normal operation of the instrument. For example, when a query command is sent, the response message is placed in the output queue.

When data is placed in the output queue, the message available (MAV) bit in the status byte register sets. A data message is cleared from the output queue when it is read. The output queue is considered cleared when it is empty. An empty output queue clears the MAV bit in the status byte register.

A message is read from the output queue by addressing the power supply to talk after the appropriate query is sent.

The following command sequence enables the MAV bit (B4) of the status byte register set, and then causes an SRQ:

<i>*SRE16</i>	` Enable MAV bit of status byte to cause an SRQ.
<i>Language specific</i>	` Send a query command to supply.
<i>Language specific</i>	` Wait for an SRQ indicating ready to read.
<i>Language specific</i>	` Read the query response.

Error queue

The error queue holds error and status messages. When an error or status event occurs, a message that defines the error/status is placed in the error queue.

When a message is placed in the error queue, the error available (EAV) bit in the status byte register is set. An error/status message is cleared from the error queue when it is read. The error queue is considered cleared when it is empty. An empty error queue clears the EAV bit in the status byte register.

The error queue holds up to 10 error/status messages. The commands to read the error queue are listed in Table 7-6. When you read a single message in the error queue, the “oldest” message is read and then removed from the queue. If the queue becomes full, the message “350, ‘queue overflow’” will occupy the last memory location. On power-up, the error queue is empty. When empty, the message “0, No Error” is placed in the queue.

Messages in the error queue are preceded by a code number. Negative (-) numbers are used for SCPI defined messages, and positive (+) numbers are used for Keithley defined messages. The messages are listed in Appendix B.

On power-up, all error messages are enabled and will go into the error queue as they occur. Status messages are not enabled and will not go into the queue. As listed in Table 7-6, there are commands to enable and/or disable messages. For these commands, the <list> parameter is used to specify which messages to enable or disable. The messages are specified by their codes. The following examples show various forms for using the <list> parameter.

```
<list> = (-110)           Single message
        = (-110:-222)     Range of messages (-110 through -222)
        = (-110:-222, -220) Range entry and single entry (separated by a comma)
```

When you enable messages, messages not specified in the list are disabled. When you disable messages, each listed message is removed from the enabled list.

NOTE To prevent all messages from entering the error queue, send the enable command along with the null list parameter as follows: `STATUS:QUEue:ENABLE ()`.

Table 7-6
SCPI commands — error queue

Command	Description	Default
STATus :QUEue [:NEXT]? :ENABLE <list> :ENABLE? :DISable <list> :DISable? :CLEar	STATus subsystem: Read error queue: Read and clear oldest error/status message. Specify error and status messages for error queue. Read the enabled messages. Specify messages not to be placed in queue. Read the disabled messages. Clear messages from error queue.	(Note 1) (Note 2) (Note 2)
SYSTem :ERRor? :CLEar	SYSTem subsystem: Read error queue: Clear messages from error queue.	(Note 1)

Notes:

1. Power-up and *CLS empties the error queue. STATUS:PRESet has no effect.
2. Power-up enables error messages and disables status messages. *CLS and STATUS:PRESet have no effect.

Programming example — read error queue

```
STAT:QUE:ENAB (+000:+900) ` Enable all Keithley defined messages (dis-
                             able all SCPI defined messages).

STAT:QUE? ` Return oldest message.
```

8 Common Commands

NOTES *This manual covers Keithley Models 2302, 2302-PJ, 2306, and 2306-PJ simulators (power supplies). Since the Model 2302 and 2302-PJ are single channel battery simulators, functions related to the second channel (i.e., the charger channel) are not available for the Model 2302 and 2302-PJ. Therefore:*

- *battery and charger channel features contained in this manual apply for the Model 2306 and 2306-PJ*
- *only battery channel features contained in this manual apply for the Model 2302 and 2302-PJ*

Refer to Appendix F for specific Model 2302 and 2302-PJ information.

Information contained in this section applies to all power supply channels (unless otherwise noted). In this manual, channel 1 refers to the battery channel while channel 2 refers to the charger channel (2306 and 2306-PJ feature only).

Overview

Common commands are device commands that are common to all devices on the bus. These commands are designated and defined by the IEEE-488.2 standard. Common commands are listed in Table 8-1. Note that detailed information on the Common Commands to program and read status registers is provided in Section 7.

Table 8-1
IEEE-488.2 common commands and queries (refer to Section 7)

Mnemonic	Name	Description
*CLS	Clear status	Clears all event registers and error queue.
*ESE <NRf>	Event enable command	Program the standard event enable register.
*ESE?	Event enable query	Read the standard event enable register.
*ESR?	Event status register query	Read the standard event enable register and clear it.
*IDN?	Identification query	Returns the manufacturer, model number, serial number, and firmware revision levels of the unit.
*OPC	Operation complete command	Set the operation complete bit in the standard event register after all pending commands have been executed.
*OPC?	Operation complete query	Places an ASCII "1" into the output queue when all pending selected device operations have been completed.
*RCL <NRf>	Recall command	Returns the power supply to the user-saved setup.
*RST	Reset command	Returns the power supply to the *RST default conditions.
*SAV <NRf>	Save command	Saves the present setup as the user-saved setup.
*SRE <NRf>	Service request enable command	Programs the service request enable register.
*SRE?	Service request enable query	Reads the service request enable register.
*STB?	Status byte query	Reads the status byte register.
*TRG[1]	Trigger command	Sends a battery channel (#1) bus trigger to the power supply.
*TRG2	Trigger command	Sends a charger channel (#2) bus trigger to the power supply.
*TST?	Self-test query	Performs a checksum test on ROM and returns the result.
*WAI	Wait-to-continue command	Wait until all previous commands are executed.

Command notes (IEEE-488.2 common commands and queries)

***IDN? — identification query** Reads identification code

The identification code includes the manufacturer, model number, serial number, and firmware revision levels.

KEITHLEY INSTRUMENTS INC., MODEL 2306, xxxxxxxx, yyyyyy/zzzzz

KEITHLEY INSTRUMENTS INC., MODEL 2306-PJ, xxxxxxxx, yyyyyy/zzzzz

Where: xxxxxxxx is the serial number.

yyyyyy/zzzzz is the firmware revision levels of the digital board and display board ROMs.

***OPC — operation complete** Sets OPC bit

***OPC? — operation complete query** Places a “1” in output queue

When *OPC is sent, the OPC bit in the standard event register will set after all pending command operations are complete. When *OPC? is sent, an ASCII “1” is placed in the output queue after all pending command operations are complete.

Typically, either one of these commands is sent after a reading or reading array is requested. While the instrument is acquiring readings, all commands (except DCL, SDC, IFC, *TRG and GET) that are sent are not executed.

After all readings are acquired, the instrument returns to the idle at which time all pending commands (including *OPC and/or *OPC?) are executed.

Syntax — The following syntax rules explain how to use *OPC and *OPC? with other commands (refer to Table 8-2 on page 8-4 for examples). *OPC and *OPC? can be used in conjunction with battery channel (#1) commands or charger channel (#2) commands (see Table 8-2).

Send *OPC or *OPC?, separated by a semicolon, on the same line with a query (see Ref. A in Table 8-2). If sent on separate lines, an error occurs (B). *OPC or *OPC? can also be sent on the same line or a separate line with a command that is not a query (C and D).

***RST — reset** Return power supply to RST defaults

When the *RST command is sent, the power supply performs the following operations:

1. Returns the instrument to the RST default conditions (see “Default” column of SCPI tables).
2. Cancels all pending commands.
3. Cancels response to any previously received *OPC and *OPC? commands.

***TRG[1] — trigger** Send battery channel (#1) bus trigger to power supply

***TRG2 — trigger** Send charger channel (#2) bus trigger to power supply

Use the *TRG command to trigger a single reading for the function presently selected. If the average count is >1, then the single reading will be the average reading.

***TST? — self-test query** Run self test and read result

Use this query command to perform a checksum test on ROM. The command places the coded result (0 or 1) in the output queue. When the power supply is addressed to talk, the coded result is sent from the output queue to the computer.

A returned value of zero (0) indicates that the test passed, and a value of one (1) indicates that the test failed.

***WAI — wait-to-continue** Wait until previous commands are completed

Effectively, the *WAI command is a no-op (no operation) for the power supply and therefore, does not need to be used.

Two types of device commands exist:

- Sequential commands — A command whose operations are allowed to finish before the next command is executed.
- Overlapped commands — A command that allows the execution of subsequent commands while device operations of the overlapped command are still in progress.

The *WAI command is used to suspend the execution of subsequent commands until the device operations of all previous overlapped commands are finished. The *WAI command is not needed for sequential commands.

9

Signal Oriented Measurement Commands

NOTES *This manual covers Keithley Models 2302, 2302-PJ, 2306, and 2306-PJ simulators (power supplies). Since the Model 2302 and 2302-PJ are single channel battery simulators, functions related to the second channel (i.e., the charger channel) are not available for the Model 2302 and 2302-PJ. Therefore:*

- *battery and charger channel features contained in this manual apply for the Model 2306 and 2306-PJ*
- *only battery channel features contained in this manual apply for the Model 2302 and 2302-PJ*

Refer to Appendix F for specific Model 2302 and 2302-PJ information.

Information contained in this section applies to all power supply channels (unless otherwise noted). In this manual, channel 1 refers to the battery channel while channel 2 refers to the charger channel (2306 and 2306-PJ feature only).

Overview

The signal oriented measurement commands are used to acquire readings. You can use these high-level instructions to control the measurement process. These commands are summarized in Table 9-1.

Table 9-1
Signal oriented measurement command summary

Command	Description
:FETCh[1]?	Returns the last reading from battery channel (#1). Triggered before reading(s).
:FETCh[1]:ARRay?	Returns the last array of readings from battery channel (#1). Triggered before reading(s).
:FETCh2?	Returns the last reading from charger channel (#2). Triggered before reading(s).
:FETCh2:ARRay?	Returns the last array of readings from charger channel (#2). Triggered before reading(s).
:READ[1]?	Triggers and returns a new battery channel (#1) reading.
:READ[1]:ARRay?	Triggers and returns a new array of battery channel (#1) readings.
:READ2?	Triggers and returns a new charger channel (#2) reading.
:READ2:ARRay?	Triggers and returns a new array of charger channel (#2) readings.
:MEASure[1][:<function>]?	Performs a READ? on the specified battery channel (#1) function.
:MEASure:ARRay[1][:<function>]?	Performs a READ:ARRay? on the specified battery channel (#1) function.
:MEASure2[:<function>]?	Performs a READ2? on the specified charger channel (#2) function.
:MEASure:ARRay2[:<function>]?	Performs a READ2:ARRay? on the specified charger channel (#2) function.

NOTE For all array queries, make sure the computer's buffer is large enough to accommodate all array readings. Overflow readings exponential format = +9.9E37.

For all non-array queries, the overflow readings exponential format also = +9.9E37.

Command notes (Signal oriented measurement commands and queries)

:FETCh[1]?	Return last reading for the battery channel (#1)
:FETCh[1]:ARRay?	Return last array of readings for the battery channel (#1)
:FETCh2?	Return last reading for the charger channel (#2)
:FETCh2:ARRay?	Return last array of readings for the charger channel (#2)

The **:FETCh?** command is used to return the last averaged reading, and the **:FETCh:ARRay?** command is used to return the last array of readings. After sending either one of these commands and addressing the power supply to talk, the averaged reading or reading array is sent to the computer. These commands do not affect the instrument setup.

These commands do not trigger measurements but are triggered before reading(s). They return the last triggered averaged reading or reading array. Note that they can repeatedly return the same reading or reading array. Until there is a new triggered reading(s), these commands continue to return the old triggered reading(s).

The number of readings to average or put in an array is set using the **SENSe:AVERage** (for voltage, current and DVM readings) or **SENSe:PCURrent:AVERage** (for pulse-current readings) command. See Sections 2 and 3 for details.

- NOTES**
1. *FETCh?* and *FETCh:ARRay?* readings are always sent in exponential form.
 2. There are no *AVERage* commands for long integration measurements. The array size for long integration readings is fixed at one. Therefore, both *FETCh?* and *FETCh:ARRay?* will return the last reading.

:READ[1]?	Trigger and return reading for the battery channel (#1)
:READ[1]:ARRay?	Trigger and return array of readings for the battery channel (#1)
:READ2?	Trigger and return reading for the charger channel (#2)
:READ2:ARRay?	Trigger and return array of readings for the charger channel (#2)

The **:READ?** command is used to trigger and return a single averaged reading, and the **:READ:ARRay?** command is used to trigger and return an array of readings for the currently selected function on the applicable channel (the battery channel being the default and the charger channel requiring a 2 to be appropriately added to the command string). The averaged reading or reading array is sent to the computer when the power supply is addressed to talk. The averaged reading is displayed on the front panel. The front panel does not show an array of readings, only the average of an array. All **:READ** commands apply to the presently selected function.

The number of readings to average or put in an array is set using the **:SENSe:AVERage** (for voltage, current and DVM readings) or **:SENSe:PCURrent:AVERage** (for pulse-current readings) command. See Sections 2 and 3 for details.

- NOTES**
1. *READ?* and *READ:ARRay?* readings are always sent in exponent form.
 2. There are no *AVERage* commands for long integration measurements. The array size for long integration readings is fixed at one. Therefore, both *READ?* and *READ:ARRay?* will return a single long integration reading.

:MEASure[1][:<function>]?	Execute :READ? on specified function for battery channel (#1)
:MEASure[1]:ARRay[:<function>]?	Execute :READ:ARRay? on specified function for battery channel (#1)
:MEASure2[:<function>]?	Execute :READ2? on specified function for charger channel (#2)
:MEASure2:ARRay[:<function>]?	Execute :READ2:ARRay? on specified function charger channel (#2)
Parameters	
<function> = CURRent[:DC]	Measure current
VOLTage[:DC]	Measure voltage
PCURrent	Measure pulse-current
DVMeter	Measure DVM input
LINTegration	Perform long integration current measurements.

When the MEASure? command is sent, the specified function is selected and then the READ? is executed. When the MEASure:ARRay? command is sent, the specified function is selected and the READ:ARRay? command is executed. See READ? and READ:ARRay? for details.

If a function is not specified, the measurement(s) will be performed on the active channel's function that is presently selected.

NOTE *There are no AVERage commands for long integration measurements. The array size for long integration readings is fixed at one. Therefore, MEASure:LINTegration? and MEASure:ARRay:LINTegration? are basically the same.*

10

DISPlay, FORMat, and SYSTem

- **DISPlay subsystem** — Covers the SCPI commands that are used to control the display.
- **FORMat subsystem** — Covers the SCPI commands to configure the format that readings are sent over the bus.
- **:SYSTem subsystem** — Covers miscellaneous SCPI commands.

NOTES *This manual covers Keithley Models 2302, 2302-PJ, 2306, and 2306-PJ simulators (power supplies). Since the Model 2302 and 2302-PJ are single channel battery simulators, functions related to the second channel (i.e., the charger channel) are not available for the Model 2302 and 2302-PJ. Therefore:*

- *battery and charger channel features contained in this manual apply for the Model 2306 and 2306-PJ*
- *only battery channel features contained in this manual apply for the Model 2302 and 2302-PJ*

Refer to Appendix F for specific Model 2302 and 2302-PJ information.

Information contained in this section applies to all power supply channels (unless otherwise noted). In this manual, channel 1 refers to the battery channel while channel 2 refers to the charger channel (2306 and 2306-PJ feature only).

DISPlay subsystem

The display subsystem controls the display of the power supply and is summarized in Table 10-1.

Table 10-1
SCPI commands — display

Command	Description	Default
:DISPlay		
:ENABle 	Turn display on or off.	(see Notes 1, 3)
:BRIGHtness <NRf>	Set brightness for VFD display. Range 0–1.0 Blank display: <NRf> = 0 1/4 brightness: <NRf> ≤ 0.25 1/2 brightness: <NRf> ≤ 0.50 3/4 brightness: <NRf> ≤ 0.75 Full brightness: <NRf> ≤ 1.0	1.0
:CHANnel <NRf>	Changes the active display channel (1 for battery and 2 for charger).	1
[:WINDow[1]]		
:TEXT	Text messages:	(see Note 1)
:DATA <a>	Define ASCII message “a” (up to 32 characters).	
:STATe 	Enable or disable text message mode.	(see Note 2)

- Note:
1. *RST or *RCL have no effect on the display circuitry and user-defined text messages.
 2. :STATe when power cycle enable is off =(0)
 3. This command is valid if DISP:ENAB is ON after a power cycle.

Command notes (SCPI commands — display)

DISPlay:ENABle 		Control display circuitry
Parameters	 = 0 or OFF	Disable display circuitry
	1 or ON	Enable display circuitry

This command is used to enable and disable the front panel display circuitry. When disabled, the instrument operates at a higher speed. While disabled, the display is blank.

All front panel controls (except LOCAL) are disabled. Normal display operation can be resumed by using the :ENABle command to enable the display or by putting the power supply into local.

DISPlay:BRIGhtness <NRf> Set brightness for VFD display

Parameters <NRf> = 0–1

Blank display: <NRf> = 0

1/4 brightness: <NRf> ≤ 0.25

1/2 brightness: <NRf> ≤ 0.50

3/4 brightness: <NRf> ≤ 0.75

Full brightness: <NRf> ≤ 1.0

This command is ignored if the Model 2304-DISP remote module is connected (the Model 2304-DISP has an LCD display). Dependent on the revision level of the Model 2304-DISP firmware, the “VFD BRIGHTNESS” menu choice may or may not be present in the main menu. If present, the front panel menu choices are as follow:

FULL BRIGHTNESS

BRIGHTNESS OFF

1 / 4 BRIGHTNESS

1 / 2 BRIGHTNESS

3 / 4 BRIGHTNESS

NOTE *Setting this option when a remote is connected (Model 2304-DISP) via remote or through the bus will be ignored. No error message will be generated.*

DISPlay:CHANnel <NRf> Sets active display channel

Parameters <NRf> = 1 or 2

To set front panel to battery channel active:<NRf> = 1

To set front panel to charger channel active:<NRf> = 2

This command sets the active channel on the front panel display. To set the front panel display to battery channel active, send a parameter of 1. To set the front panel display to charger channel active, send a parameter of 2.

From the front panel, the ◀ and ▶ keys will toggle the active display channel between channel #1 (battery channel) and channel #2 (charger channel). Note that changing active channels using this method (◀ and ▶ keys) is only available from one of the following areas:

- display menu,
- main menu,
- pulse current top level menu,
- long integration top level menu,
- and display of data readings.

DISPlay:TEXT:DATA <a> Define message on display

:DISPlay[:WINDow[1]]:TEXT:DATA <a>

Parameters <a> = ASCII characters for message

Types: String 'aa...a' or "aa...a"
 Indefinite Block #0aa...a

This command defines a text message for the display. A message is made up of 32 characters and starts on the top line of the display and wraps down to the bottom line. Spaces are counted as characters and can be used to properly position the message on the display. If your message is less than 32 characters, the appropriate number of spaces are added at the end. If your message is greater than 32 characters, it will not be displayed. On power-up, the message is a string of 32 spaces.

An indefinite block message must be the only command in the program message or the last command in the program message. If you include a command after an indefinite block message (on the same line), it will be treated as part of the message and is displayed instead of executed.

NOTE Use *DISPlay:TEXT:STATe * to enable the text message mode.

**DISPlay:TEXT:STATe ** Control message

:DISPlay[:WINDow[1]]:TEXT:STATe

Parameters : = 0 or OFF Disable text message
 1 or ON Enable text message

This command enables or disables the text message mode. When enabled, the text message is displayed. If no message is defined, a string of 32 spaces is displayed. When disabled, the message is removed from display. The display returns to the normal display state.

A text message remains displayed only as long as the instrument is in remote. Taking the instrument out of remote (by pressing the LOCAL key or sending GTL) cancels the message and disables the text message mode.

FORMat subsystem

The commands for this subsystem are used to select the data format for transferring instrument readings over the bus. These commands are summarized in Table 10-2.

Table 10-2
SCPI commands — data format

Command	Description	Default
FORMat [:DATA] <type> :BORDER <name>	Specify data format; ASCii, SREal or DREal. Specify byte order; NORMal or SWAPped.	ASCii SWAP

Command notes (SCPI commands — data format)

FORMat[:DATA] <type>		Select data format
Parameters	<type>	
	= ASCii	ASCII format
	SREal	IEEE754 single precision format
	DREal	IEEE754 double precision format

This command is used to select the data format for transferring readings over the bus. The reading(s) that is sent depends on the presently selected function (voltage, current, pulse-current, DVM or long integration). See the :FUNCTION command (SENSE subsystem in Section 2) and “Signal Oriented Measurement Commands” (Section 9) for more information.

NOTE *Regardless of which data format for output strings is selected, the power supply will only respond to input commands using the ASCII format.*

ASCII format

The ASCII data format is in a direct readable form for the operator. Most Basic languages easily convert ASCII mantissa and exponent to other formats. However, some speed is compromised to accommodate the conversion. The following shows the ASCII format for a reading of 10.058 volts.

+1.00580000 E+01

IEEE754 formats

SREal will select the binary IEEE-754 single precision data format. Figure 10-1 shows the normal byte order format for each data element (voltage, current, etc.). Note that the data string for each reading conversion is preceded by a 2-byte header that is the binary equivalent of an ASCII # sign and 0. Not shown in Figure 10-1 is a byte for the terminator that is attached to the end of each data string.

Figure 10-1
IEEE-754 single precision data format

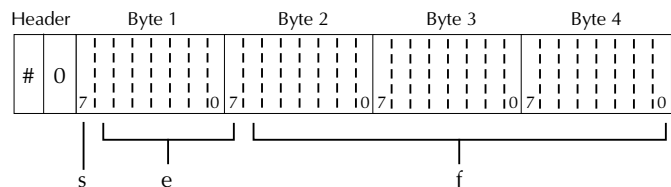

s = sign bit (0 = positive, 1 = negative)
e = exponent bits (8)
f = fraction bits (23)

Normal byte order shown. For swapped byte order,
bytes sent in reverse order: Header, Byte 4, Byte 3,
Byte 2, Byte 1.

The Header is only sent once for each measurement conversion.

DREal selects the binary IEEE-754 double precision data format and is shown in Figure 10-2 (normal byte order shown). This format is similar to the single precision format except that it is 64 bits long.

Figure 10-2
IEEE-754 double precision data format

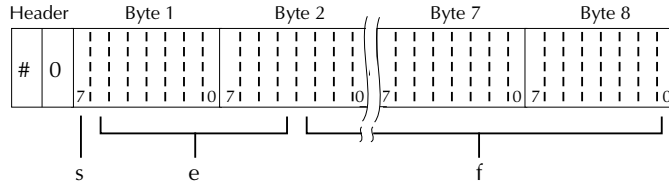

Bytes 3, 4, 5, and 6 not shown.

s = sign bit (0 = positive, 1 = negative)

e = exponent bits (11)

f = fraction bits (52)

Normal byte order shown. For swapped byte order,
bytes sent in reverse order: Header, Byte 8,
Byte 7 Byte 1.

The Header is only sent once for each measurement conversion.

During binary transfers, never un-talk the power supply until after the data is read (input) to the computer. Also, to avoid erratic operation, the readings of the data string (and terminator) should be acquired in one piece. The header (#0) can be read separately before the rest of the string.

The number of bytes to be transferred can be calculated as follows:

$$\text{Bytes} = 2 + (\text{Rdgs} \times 4) + 1 \text{ for SREAL}$$

$$\text{Bytes} = 2 + (\text{Rdgs} \times 8) + 1 \text{ for DREAL}$$

where: 2 is the number of bytes for the header (#0).

Rdgs is the number of readings to be transferred.

4 or 8 is the number of bytes for each reading.

1 is the byte for the terminator.

For example, assume that the power supply is configured to trigger 10 voltage readings and send the 10 voltage measurements to the computer using the binary format.

$$\text{Bytes} = 2 + (10 \times 4) + 1 = 43 \text{ for SREAL}$$

$$\text{Bytes} = 2 + (10 \times 8) + 1 = 83 \text{ for DREAL}$$

FORMat:BORDER <name>		Specify binary byte order
Parameters	<name> = NORMAL	Normal byte order for binary formats
	SWAPped	Reverse byte order for binary formats

This command is used to control the byte order for the IEEE-754 binary formats. For normal byte order, the data format for each element is sent as follows:

Byte 1	Byte 2	Byte 3	Byte 4	(Single precision)
Byte 1	Byte 2	•••	Byte 8	(Double precision)

For reverse byte order, the data format for each element is sent as follows:

Byte 4	Byte 3	Byte 2	Byte 1	(Single precision)
Byte 8	Byte 7	•••	Byte 1	(Double precision)

The "#,0" header is not affected by this command. The header is always sent at the beginning of the data string for each measurement conversion.

The ASCII data format can only be sent in the normal byte order. The SWAPped selection is ignored when the ASCII format is selected.

:SYSTem subsystem

The SYSTem subsystem contains miscellaneous commands (summarized in Table 10-3).

Table 10-3
SCPI commands — system

Command	Description	Default	Ref
SYSTem			
:LFRequency?	Read power line frequency.		Sec 1*
:POSetup <name>	Select power-on setup: RST or SAVx where: x = 0 to 4		
:VERsion?	Query SCPI revision level.		
:ERRor	Read and clear oldest message in error queue:	(see Note)	Sec 7
:CLEar	Clear messages from error queue.		Sec 7

* See "Line power connection" under "Power-up" in Section 1 for details.

Note: Clearing the error queue — Power-up and *CLS clears the error queue. *RST and STATus:PRESet have no effect on the error queue.

Command notes (SCPI commands — system)

SYSTEM:POSetup <name>			Program power-on defaults
Parameters	<name> =	RST	Power-up to *RST defaults
		SAV0	Power-up to setup stored in memory location 0
		SAV1	Power-up to setup stored in memory location 1
		SAV2	Power-up to setup stored in memory location 2
		SAV3	Power-up to setup stored in memory location 3
		SAV4	Power-up to setup stored in memory location 4

With RST selected, the power supply powers up to the *RST default conditions. Default conditions are listed in the SCPI tables.

With SAV0-4 specified, the power supply powers-on to the setup that is saved in the specified memory location using the *SAV command (Section 8). Note that the instrument will power up with the output OFF.

11

SCPI Tables

NOTES *This manual covers Keithley Models 2302, 2302-PJ, 2306, and 2306-PJ simulators (power supplies). Since the Model 2302 and 2302-PJ are single channel battery simulators, functions related to the second channel (i.e., the charger channel) are not available for the Model 2302 and 2302-PJ. Therefore:*

- *battery and charger channel features contained in this manual apply for the Model 2306 and 2306-PJ*
- *only battery channel features contained in this manual apply for the Model 2302 and 2302-PJ*

Refer to Appendix F for specific Model 2302 and 2302-PJ information.

Information contained in this section applies to all power supply channels (unless otherwise noted). In this manual, channel 1 refers to the battery channel while channel 2 refers to the charger channel (2306 and 2306-PJ feature only).

SCPI command subsystems reference tables

Tables 11-1 to 11-8 summarize the commands for each SCPI subsystem. The following list includes the table numbers and page numbers for each SCPI subsystem command summary.

Table	Title	Page
11-1	DISPlay command summary.....	11-3
11-2	FORMat command summary.....	11-3
11-3	OUTPut command summary.....	11-4
11-4	SENSE command summary.....	11-5
11-5	SOURce command summary.....	11-14
11-6	STATus command summary.....	11-15
11-7	SYSTem command summary.....	11-17
11-8	Signal oriented measurement command summary	11-17

General notes

- Brackets ([]) are used to denote optional character sets. These optional characters do not have to be included in the program message. Do not use brackets in the program message.
- Angle brackets (<>) are used to indicate parameter type. Do not use angle brackets in the program message.
- SCPI — A checkmark (✓) indicates that the command and its parameters are SCPI confirmed. An unmarked command indicates that it is a SCPI command but does not conform to the SCPI standard set of commands. It is not a recognized command by the SCPI consortium. SCPI confirmed commands that use one or more non-SCPI parameters are explained by notes.
- Refer to Section 6 for GPIB operation.
- Refer to Section 8 for common commands.
- Refer to table title for more command information.

Table 11-1*Display command summary (refer to Display subsystem in Section 10)*

Command	Description	Default parameter	SCPI
:DISPlay			
:ENABle 	Enable or disable display.	ON (Note 1)	✓
:ENABle?	Query state of display.		✓
:BRIGhtness <NRf>	Set brightness for VFD display. Range 0.000–1.000 Blank display: <NRf> = 0 1/4 brightness: <NRf> ≤ 0.25 1/2 brightness: <NRf> ≤ 0.50 3/4 brightness: <NRf> ≤ 0.75 Full brightness: <NRf> ≤ 1.0	1 (Full brightness)	
:BRIGhtness?	Query brightness of display.		
:CHANnel <NRf>	Changes the active display channel (1 for battery and 2 for charger).	1	
:CHANnel?	Query the active display channel setting.		
[:WINDow[1]]	Path to locate message to display:		✓
:TEXT	Control user text message:	(Note 2)	✓
:DATA <a>	Define ASCII message “a” (up to 32 characters).	String of 32 spaces	✓
:DATA?	Query text message.		✓
:STATe 	Enable or disable message mode.	OFF (Note 3)	✓
:STATe?	Query state of message mode.		✓

Notes: 1. *RST and *RCL have no effect on display circuitry. Cycling power enables (ON) the display circuit.

2. *RST and *RCL have no effect on a user-defined message. Cycling power cancels all user-defined messages.

3. *RST and *RCL have no effect on the state of the message mode. Cycling power disables (OFF) the message mode.

Table 11-2*FORMat command summary (refer to Format subsystem in Section 10)*

Command	Description	Default parameter	SCPI
:FORMat			
[:DATA] <type>	Specify data format (ASCii, SREal, or DREal).	ASCii	✓
[:DATA]?	Query data format.		✓
:BORDer <name>	Specify byte order (NORMal or SWAPped).	SWAPped	✓
:BORDer?	Query byte order.		✓

Table 11-3

OUTPut command summary (refer to Tables 2-3 and 5-2)

Command	Description	Default parameter	SCPI
:OUTPut[1]	OUTPut subsystem for channel #1 (battery channel)		✓
[:STATe] 	Turn output ON or OFF.	OFF	✓
[:STATe]?	Query state of output.		✓
:BANDwidth	Specifies HIGH or LOW bandwidth when the output state is ON and current range is set to 5A. When output is OFF, the bandwidth is LOW. When current range is 5mA, bandwidth is LOW.	LOW*	
:BANDwidth?	Query bandwidth setting for when output is ON and not on 5mA range.		
:IMPedance <Nrf>	Specifies the output impedance to apply 0 (OFF) to 1 Ω (max) in 10m Ω steps.	0	
:IMPedance?	Query impedance setting.		
:RELAy1 <name>	Close (ONE) or open (ZERO) relay control circuit for relay 1.	ZERO	
:RELAy1?	Query the value at relay 1 port pin digital I/O.		
:RELAy2 <name>	Close (ONE) or open (ZERO) relay control circuit for relay 2.	ZERO	
:RELAy2?	Query the value at relay 2 port pin digital I/O.		
:RELAy3 <name>	Close (ONE) or open (ZERO) relay control circuit for relay 3.	ZERO	
:RELAy3?	Query the value at relay 3 port pin digital I/O.		
:RELAy4 <name>	Close (ONE) or open (ZERO) control circuit for relay 4.	ZERO	
:RELAy4?	Query the value at relay 4 port pin digital I/O.		
:OUTPut2	OUTPut subsystem for channel #2 (charger channel)		✓
[:STATe] 	Turn output ON or OFF.	OFF	✓
[:STATe]?	Query state of output.		✓
:BANDwidth	Specifies HIGH or LOW bandwidth when the output state is ON and current range is set to 5A. When output is OFF, the bandwidth is LOW. When current range is 5mA, bandwidth is LOW.	HIGH	
:BANDwidth?	Query bandwidth setting for when output is ON and not on 5mA range.		
:BOTHOUTON	Turns both power supply channels ON.**		
:BOTHOUTOFF	Turns both power supply channels OFF.**		

*Default is HIGH for firmware version B02 and lower (does not apply to Model 2306-PJ).

**No query or short form exists.

Table 11-4

SENSe command summary (refer to Tables 2-3, 3-2, and 4-2)

Command	Description	Default parameter	SCPI
:SENSe[1]	SENSe subsystem for channel #1 (battery channel)		
:FUNCTion <name>	Select measurement function (“VOLTage,” “CURRENT,” “DVMeter,” “PCURrent,” or “LINTegration”).	VOLT	
:FUNCTion?	Query measurement function.		
:NPLCycles <n>	Specify integration rate (in line cycles) for voltage, current, and DVM measurements (0.01 to 10).	1	✓
:NPLCycles?	Query integration rate.		✓
:AVERAge <NRf>	Specify the average count for voltage, current, and DVM measurements (1 to 10).	1	
:AVERAge?	Query average count.		
:CURRent [:DC]	Path to configure the current measurement function:		✓
:RANGe	Current measurement range:		✓
[:UPPer] <NRf>	Specify expected current measurement which will select 5mA or 5A amp range for the Model 2306, or 500mA or 5A for the 2306-PJ.	5.0	✓
[:UPPer]?	Query current measurement range.		✓
:AUTO 	Enable or disable auto range.	OFF	✓
:AUTO?	Query state of auto range.		
:PCURrent	Path to configure the pulse-current measurement function (see Section 3):		
:AVERAge <NRf>	Specify average count (dependent on SYNC:STAT): pulse-current measurements: 1 to 100 (sync ON) pulse current digitization: 1 to 5000 (sync OFF)	1	
:AVERAge?	Query average count (dependent on SYNC:STAT).		
:MODE <name>	Select pulse-current measurement mode (HIGH, LOW, or AVERAge).	HIGH	
:MODE?	Query pulse-current measurement mode.		
:TIME	Path to set pulse-current integration times:		
:AUTO	Power supply sets integration times — accounts for internal trigger delay but not user delay (:DEL).		
:HIGH <NRf>	Specify integration time (in sec) for high pulse measurements (33.33E-06 to 0.8333) — accounts neither for internal trigger delay nor user delay.	3.333E-05	

Table 11-4*SENSe command summary (refer to Tables 2-3, 3-2, and 4-2) (cont.)*

Command	Description	Default parameter	SCPI
<i>:SENSe[1]</i> <i>:PCURrent</i> <i>:TIME (cont.)</i>			
<i>:HIGH?</i>	Query high integration time.		
<i>:LOW <NRf></i>	Specify integration time (in sec) for low pulse measurements (33.33E-06 to 0.8333) — accounts neither for internal trigger delay nor user delay.	3.333E-05	
<i>:LOW?</i>	Query low integration time.		
<i>:AVERAge <NRf></i>	Set integration time in seconds for measurement of pulse AVERAge time — accounts neither for internal trigger delay nor user delay.	3.333E-05	
<i>:AVERAge?</i>	Query integration time for pulse average.		
<i>:STEP </i>	To perform a series of step measurements, set to ON.	OFF	
<i>:STEP?</i>	Query state for performing step measurements.		
<i>:UP <NRf></i>	Specify number of UP steps <0-20> (max is for both up and down combined).	1	
<i>:UP?</i>	Query number of UP steps specified.		
<i>:DOWN <NRf></i>	Specify number of DOWN steps <0-20> (max is for both up and down combined).	1	
<i>:DOWN?</i>	Query number of DOWN steps specified.		
<i>:TIME <NRf></i>	Specify step integration time for UP plus DOWN steps: 33µsec–100msec.	200µsec	
<i>:TIME?</i>	Query step integration time specified for UP plus DOWN steps.		
<i>:TimeOUT <NRf></i>	Step TimeOUT (other than the first step): 2msec–200msec.	2ms	
<i>:TimeOUT?</i>	Query step TimeOUT setting for all steps but the first step.		
<i>:INITial <NRf></i>	TimeOUT for the first step: 10msec–60secs.	2sec	
<i>:INITial?</i>	Query TimeOUT setting for the first step.		

Table 11-4

SENSe command summary (refer to Tables 2-3, 3-2, and 4-2) (cont.)

Command	Description	Default parameter	SCPI
:SENSe[1] :PCURrent :STEP			
:DELay <NRf>	Step delay: 0msec—100msec (in 10sec steps).	0	
:DELay?	Query setting for step delay.		
:RANGe <NRf>	Set step trigger level range for 5A current range: 100mA, 1A, 5A.	5A	
:RANGe?	Query setting for step trigger level range for 5A current range.		
:MILLiamp <NRf>	Model 2306-PJ only when on 500mA current range. The parameter <NRf> sent with this command causes the trigger to be set with the trigger level setting of HALFamp, HUNDred, or TEN.		
:MILLiamp?	Model 2306-PJ only Query the trigger level setting on the 500mA current range. Receives responses in amps of 0.5, 0.1, or 0.01, accordingly.		
:TLEVx <NRf>	Set trigger level for each TLEV step (<i>x</i> equals 1—20) (0.0—maxA where max is 100mA for 100mA range, 1A for 1A range, and 5A for 5A range setting).	0.0	
:TLEVx?	Query setting for trigger level for each TLEV step (<i>x</i> equals 1—20).		
:SYNChronize	Pulse detection triggering:		
[:STATe]	Send ON to select pulse current measurements or OFF to select pulse current digitization.	ON	
:TLEVel	Trigger level:		
[:AMP] <NRf>	Set trigger level (in amps) for 5A range on 5A current range: 0.0–5.0.	0.0	
[:AMP]?	Query setting for trigger level on 5A range.		
:ONE <NRf>	Set trigger level (in amps) for 1A range on 5A current range: 0.0–1.0.	0.0	
:ONE?	Query setting for trigger level on 1A range.		

Table 11-4

SENSe command summary (refer to Tables 2-3, 3-2, and 4-2) (cont.)

Command	Description	Default parameter	SCPI
:SENSe[1] :PCURrent :SYNChronize :TLEVel			
:MILLiamp <NRf>	Set trigger level (in amps) for 100mA range on 5A current range: 0.0–0.1.	0.0	
:MILLiamp?	Query setting for trigger level on 100mA range.		
:HALFamp <NRf>	Model 2306-PJ only — Set trigger level (in amps) for 500mA range on 500mA current range: 0-500mA	0.0	
:HALFamp?	Model 2306-PJ only — Query the 500mA trigger level setting on the 500mA current range.		
:HUNDred <NRf>	Model 2306-PJ only — Set trigger level (in amps) for 100mA range on 500mA current range: 0-100mA	0.0	
:HUNDred?	Model 2306-PJ only — Query the 100mA trigger level setting on the 500mA current range.		
:TEN <NRf>	Model 2306-PJ only — Set trigger level (in amps) for 10mA range on 500mA current range: 0-10mA	0.0	
:TEN?	Model 2306-PJ only — Query the 10mA trigger level setting on the 500mA current range.		
:RANGe <NRf>	Set trigger level range (100mA, 1A, or 5A) for the 5A current range. The parameter <NRf> sent with this command causes the trigger to be set with the trigger level setting of MILL, ONE, or AMP. Queries receive responses of 0.1, 1.0, or 5.0 accordingly. In other words, if a value of 2.0A is sent with the command, a value of 5A will be returned as a response to a query.	5A	
:RANGe?	Query selected trigger level range for the 5A current range.		
:MILLiamp <NRf>	Model 2306-PJ only — when on 500mA current range. The parameter <NRf> sent with this command causes the trigger to be set with the trigger level setting of HALFamp, HUNDred, or TEN.		

Table 11-4*SENSe command summary (refer to Tables 2-3, 3-2, and 4-2) (cont.)*

Command	Description	Default parameter	SCPI
:SENSe[1] :PCURrent :SYNChronize :TLEVel :MILLiamp?	Model 2306-PJ only — Query the trigger level setting on the 500mA current range. Receives responses in amps of 0.5, 0.1, or 0.01, accordingly.		
:DELay <NRf>	Specify trigger delay in seconds: 0.0–0.1 (pulse current measurements) or 0.0–5.0 (pulse current digitization).	0.0	
:DELay?	Query specified trigger delay (dependent on SYNC:STAT).		
:FAST	Enable or disable pulse current fast readings.	OFF	
:SEARCh	Enable or disable pulse current search.	ON	
:DETECT	Enable or disable pulse current detection mode.	OFF	
:TimeOUT	Specify length of timeout: 5ms -1000ms (1 second) incrementing in 1ms.	1 (sec)	
:LINTegration	Path to configure long integration measurements (refer to Section 4):		
:TEDGe <name>	Set trigger edge to start long integration measurement (RISING, FALLING, NEITHER).	RISING	
:TEDGe?	Query trigger edge setting.		
:TIME <NRf>	Set integration time in seconds: X to 60 where X is 0.850 for 60Hz line frequency or 0.840 for 50Hz line frequency.	1.00	
:TIME?	Query integration time.		
:AUTO	Power supply sets integration time.		
:TLEVel	Path to set trigger level.		
[:AMP] <NRf>	Set trigger level for 5A range: 0 to 5 (amps).	0	
[:AMP]?	Query trigger level for 5A range.		
:ONE <NRf>	Set trigger level for 1A range: 0 to 1 (amps).	0	
:ONE?	Query trigger level for 1A range.		
:MILLiamp <NRf>	Set trigger level for 100mA range: 0 to 0.1 (amps).	0	

Table 11-4

SENSe command summary (refer to Tables 2-3, 3-2, and 4-2) (cont.)

Command	Description	Default parameter	SCPI
:SENSe[1] :LINTegration :TLEVel			
:MILLiamp?	Query trigger level for 100mA range.		
:HALFamp <NRf>	Model 2306-PJ only — Set trigger level (in amps) for 500mA range on 500mA current range: 0-500mA	0.0	
:HALFamp?	Model 2306-PJ only — Query the 500mA trigger level setting on the 500mA current range.		
:HUNDred <NRf>	Model 2306-PJ only — Set trigger level (in amps) for 100mA range on 500mA current range: 0-100mA	0.0	
:HUNDred?	Model 2306-PJ only — Query the 100mA trigger level setting on the 500mA current range.		
:TEN <NRf>	Model 2306-PJ only — Set trigger level (in amps) for 10mA range on 500mA current range: 0-10mA	0.0	
:TEN?	Model 2306-PJ only — Query the 10mA trigger level setting on the 500mA current range.		
:RANGe <NRf>	Select trigger level range (100mA, 1A, 5A) for the 5A current range based on <NRf> which causes AMP, ONE, or MILL setting to be used for trigger level.	5.0	
:RANGe?	Query trigger level range for the 5A current range.		
:MILLiamp <NRf>	Model 2306-PJ only when on 500mA current range. The parameter <NRf> sent with this command causes the trigger to be set with the trigger level setting of HALFamp, HUNDred, or TEN.		
:MILLiamp?	Model 2306-PJ only Query the trigger level setting on the 500mA current range. Receives responses in amps of 0.5, 0.1, or 0.01, accordingly.		
:TimeOUT <NRf>	Specify length of timeout: 1 to 63 (seconds).	16	
:TimeOUT?	Query timeout.		
:SEARch 	Enable or disable pulse search.	ON	
:SEARch?	Query state of pulse search.		
:FAST 	Enable or disable long integration fast readings mode.	OFF	

Table 11-4

SENSe command summary (refer to Tables 2-3, 3-2, and 4-2) (cont.)

Command	Description	Default parameter	SCPI
:SENSe2 :PCURrent :TIME :AUTO	Power supply sets integration times — accounts for internal trigger delay but not user delay (:DEL).		
:HIGH <NRf>	Specify integration time (in sec) for high pulse measurements (33.33E-06 to 0.8333) — accounts neither for internal trigger delay nor user delay.	3.333E-05	
:HIGH?	Query high integration time.		
:LOW <NRf>	Specify integration time (in sec) for low pulse measurements (33.33E-06 to 0.8333) — accounts neither for internal trigger delay nor user delay.	3.333E-05	
:LOW?	Query low integration time.		
:AVERAge <NRf>	Set integration time in seconds for measurement of pulse AVERAge time — accounts neither for internal trigger delay nor user delay.	3.333E-05	
:AVERAge?	Query average integration time.		
:SYNChronize [:STATe] 	Path for pulse detection triggering: Send ON to select pulse current measurements, or OFF to select pulse current digitization.	ON	
[:STATe]?	Query pulse current synchronization selection.		
:DELay <NRf>	Specify trigger delay in seconds (dependent on SYNC:STAT): pulse-current measurements: 0 to 0.1 (sync ON) pulse current digitization: 0 to 5 (sync OFF)	0	
:DELay?	Query specified trigger delay (dependent on SYNC:STAT).		
:TLEVel <NRf>	Set trigger level value 0–5A.	0	
:TLEVel?	Query trigger level setting.		
:FAST	Enable or disable pulse current fast readings.	OFF	
:SEARch	Enable or disable pulse current search.	ON	
:DETECT	Enable or disable pulse current detection mode.	OFF	
:TimeOUT	Specify length of timeout: 5ms -1000ms (1 second) incrementing in 1ms.	1 (sec)	

Table 11-4

SENSe command summary (refer to Tables 2-3, 3-2, and 4-2) (cont.)

Command	Description	Default parameter	SCPI
:SENSe2			
:LINTegration	Path to configure long integration measurements (refer to Section 4):		
:TEDGe <name>	Set trigger edge to start long integration measurement (RISING, FALLING, NEITHER).	RISING	
:TEDGe?	Query trigger edge setting.		
:TIME <NRf>	Set integration time in seconds: X to 60 where X is 0.850 for 60Hz or 0.840 for 50Hz).	1.00	
:TIME?	Query integrations time.		
:AUTO	Power supply sets integrations time.		
:TLEVel <NRf>	Set trigger level value 0–5A.	0	
:TLEVel?	Query trigger level setting.		
:TimeOUT <NRf>	Specify length of timeout: 1 to 63 (seconds).	16	
:TimeOUT?	Query timeout.		
:SEARch 	Enable or disable pulse search.	ON	
:SEARch?	Query state of pulse search.		
:FAST 	Enable or disable long integration fast readings mode.	OFF	
:FAST?	Query long integration fast readings mode.		
:DETECT 	Enable or disable long integration detect pulse only mode.	OFF	
:DETECT?	Query detect mode.		

Table 11-5
SOURce command summary (cont.) (refer to Table 2-3)

Command	Description	Default parameter	SCPI
:SOURce2 :CURRent [:LIMit] [:VALue] <NRf> [:VALue]? :TYPE <name> :TYPE? :STATe?	Specify current limit value in amps: 0.006–5 with 100µA resolution. Query current limit. Select current limit type: LIMit or TRIP. Query current limit type. Query state of current limit: 1 = in current limit (for LIMit type) or output tripped (for TRIP type), 0 = not in LIMit/TRIP.	0.25 LIM	

Table 11-6
STATus command summary (refer to Section 7)

Command	Description	Default parameter	SCPI
:STATus		(Note 1)	✓
:MEASurement	Path to control the measurement event registers:		
[:EVENT]?	Read the event register.	(Note 2)	
:ENABLE <NRf>	Program the enable register.	(Note 3)	
:ENABLE?	Read the enable register.		
:CONDition?	Read the condition register.		
:OPERation	Path to control the operation status registers:		✓
[:EVENT]?	Read the event register.	(Note 2)	✓
:ENABLE <NRf>	Program the enable register.	(Note 3)	✓
:ENABLE?	Read the enable register.		✓

- Notes: 1. Commands in this subsystem are not affected by *RST. The effects of cycling power, *CLS, and :STATus:PRESet are explained by the following notes.
- Event registers
 Power-up and *CLS — Clears all bits of the registers
 :STATus:PRESet — No effect
 - Enable registers
 Power-up and :STATus:PRESet — Clears all bits of the registers
 *CLS — No effect
 - Error queue
 Power-up and *CLS — Clears the error queue
 :STATus:PRESet — No effect
 - Enable/disable error queue messages
 Power-up — Clears list of messages
 *CLS and :STATus:PRESet — No effect

Table 11-6
STATus command summary (cont.) (refer to Section 7)

Command	Description	Default parameter	SCPI
<i>:STATus</i> <i>:OPERation</i>			
<i>:CONDition?</i>	Read the condition register.		✓
<i>:QUESTionable</i>	Path to control the questionable status registers:		✓
<i>[:EVENT]?</i>	Read the event register.	(Note 2)	✓
<i>:ENABLE <NRf></i>	Program the enable register.	(Note 3)	✓
<i>:ENABLE?</i>	Read the enable register.		✓
<i>:CONDition?</i>	Read the condition register.		✓
<i>:PRESet</i>	Return status registers to default states.		✓
<i>:QUEue</i>	Path to access error queue.		✓
<i>[:NEXT]?</i>	Read the least recent error message.	(Note 4)	✓
<i>:ENABLE <list></i>	Specify error and status messages for queue.	(Note 5)	✓
<i>:ENABLE?</i>	Read the enabled list of messages.		✓
<i>:DISable <list></i>	Specify messages not to be placed in queue.	(Note 5)	✓
<i>:DISable?</i>	Read the disabled messages.		✓
<i>:CLEar</i>	Clear all messages from error queue.		✓

Notes: 1. Commands in this subsystem are not affected by *RST. The effects of cycling power, *CLS, and :STATus:PRESet are explained by the following notes.

- Event registers
Power-up and *CLS — Clears all bits of the registers
:STATus:PRESet — No effect
- Enable registers
Power-up and :STATus:PRESet — Clears all bits of the registers
*CLS — No effect
- Error queue
Power-up and *CLS — Clears the error queue
:STATus:PRESet — No effect
- Enable/disable error queue messages
Power-up — Clears list of messages
*CLS and :STATus:PRESet — No effect

Table 11-7
SYSTEM command summary (refer to System subsystem in Section 10)

Command	Description	Default parameter	SCPI
:SYSTem :VERSion? :ERRor? :CLEar :LFRequency? :POSetup <name> :POSetup?	Query SCPI version level. Read and clear oldest message in error queue. Clears error queue. Query power line frequency setting. Select power-on setup: RST or SAVx, where: x = 0 to 4 Query power-on setup.	RST	✓

Table 11-8
Signal oriented measurement command summary (refer to Section 9)

Command	Description
:FETCh[1]? :FETCh[1]:ARRay?	Returns the last triggered reading from battery channel (#1). Returns the last array of triggered readings from battery channel (#1).
:FETCh2? :FETCh2:ARRay?	Returns the last triggered reading from charger channel (#2). Returns the last array of triggered readings from charger channel (#2).
:READ[1]? :READ[1]:ARRay? :READ2? :READ2:ARRay?	Triggers and returns a new battery channel (#1) reading. Triggers and returns a new array of battery channel (#1) readings. Triggers and returns a new charger channel (#2) reading. Triggers and returns a new array of charger channel (#2) readings.
:MEASure[1][:<function>]? :MEASure:ARRay[1][:<function>]? :MEASure2[:<function>]? :MEASure:ARRay2[:<function>]?	Performs a READ? on the specified battery channel (#1) function. Performs a READ:ARRay? on the specified battery channel (#1) function. Performs a READ2? on the specified charger channel (#2) function. Performs a READ2:ARRay? on the specified charger channel (#2) function.

12

Performance Verification

NOTES *This manual covers Keithley Models 2302, 2302-PJ, 2306, and 2306-PJ simulators (power supplies). Since the Model 2302 and 2302-PJ are single channel battery simulators, functions related to the second channel (i.e., the charger channel) are not available for the Model 2302 and 2302-PJ. Therefore:*

- *battery and charger channel features contained in this manual apply for the Model 2306 and 2306-PJ*
- *only battery channel features contained in this manual apply for the Model 2302 and 2302-PJ*

Refer to Appendix F for specific Model 2302 and 2302-PJ information.

Information contained in this section applies to all power supply channels (unless otherwise noted). In this manual, channel 1 refers to the battery channel while channel 2 refers to the charger channel (2306 and 2306-PJ feature only).

Introduction

NOTE *Unless otherwise noted, Model 2306 refers to Models 2306, 2306-PJ, 2302, and 2302-PJ while Model 2306 (only) refers to the specific Model 2306 (not 2306-PJ, etc.). Other Model numbers refer specifically to their respective models.*

Use the procedures in this section to verify that Model 2306 accuracy is within the limits stated in the accuracy specifications. You can perform these verification procedures:

- When you first receive the unit to make sure that it was not damaged during shipment.
- To verify that the unit meets factory specifications.
- To determine if calibration is required.
- Following calibration to make sure it was performed properly.

WARNING **The information in this section is intended only for qualified service personnel. Do not attempt these procedures unless you are qualified to do so.**

NOTE *If the unit is still under warranty, and its performance is outside specified limits, contact your Keithley representative or the factory to determine the correct course of action.*

Verification test requirements

Be sure that you perform the verification tests:

- Under the proper environmental conditions.
- After the specified warm-up period.
- Using the correct line voltage.
- Using the proper test equipment.
- Using the specified output signals and reading limits.

Environmental conditions

Conduct your performance verification procedures in a test environment with:

- An ambient temperature of 18-28°C (65-82°F).
- A relative humidity of less than 70% unless otherwise noted.

Warm-up period

Allow the Model 2306 to warm up for at least one hour before conducting the verification procedures.

If the unit has been subjected to temperature extremes (those outside the ranges stated above), allow additional time for the instrument's internal temperature to stabilize. Typically, allow one extra hour to stabilize a unit that is 10°C (18°F) outside the specified temperature range.

Allow the test equipment to warm up for the minimum time specified by the manufacturer.

Line power

The Model 2306 requires a line voltage of 100 to 240V and a line frequency of 50 or 60Hz. Verification tests must be performed within this range.

Recommended test equipment

Table 12-1 summarizes recommended verification equipment. You can use alternate equipment as long as that equipment has specifications at least four times better than corresponding Model 2306 specifications. Keep in mind, however, that test equipment accuracy will add to the uncertainty of each measurement.

Table 12-1
Recommended verification equipment

Description	Manufacturer/Model	Specifications
Digital Multimeter	Keithley 2001	DC Voltage ¹ 20V: ± 22 ppm Resistance ¹ 20 Ω : ± 59 ppm 200 Ω : ± 43 ppm 20k Ω : ± 36 ppm
Precision Resistor		1 Ω , 0.1%, 100W ²
Precision Resistor		30 Ω , 0.1%, 50W ³
Precision Resistor		3k Ω , 0.1%, 0.25W ²

¹ Full-range, 90-day, 23°C various measurement points.

² Characterize resistor using 4-wire ohms function of DMM before use.

³ Required only for Models 2306-PJ and 2302-PJ. Characterize resistor using 4-wire ohms function and 200OHM range of DMM before use. See Resistor considerations for temperature coefficient.

Resistor connections

When performing the verification tests that use the precision resistors, be sure to connect the Model 2306 OUTPUT #1 or OUTPUT #2 SENSE leads and DMM test leads as close to the resistor body as possible.

Resistor considerations

The test resistors should be characterized using the lowest possible range and the 4-wire ohms function of the DMM recommended in Table 12-1 to measure the resistance values. Use the measured resistance values to calculate the actual currents during the test procedures.

NOTE *The temperature coefficient and temperature change of the 1 Ω resistor when passing current at full load must be low enough so that the change in resistance does not cause incorrect readings. This is summarized in the following equation:*

$$\frac{V_{OUT}}{(R + \Delta R)} < 25\% \text{ of Model 2306 amps specification}$$

where: V_{OUT} is the Model 2306 output voltage
 R is the characterized value of the resistor
 ΔR is the change in resistance caused by heating

Verification limits

The verification limits stated in this section have been calculated using only the Model 2306 accuracy specifications, and they do not include test equipment uncertainty. If a particular measurement falls outside the allowable range, recalculate new limits based both on Model 2306 specifications and corresponding test equipment specifications.

Example limits calculation

As an example of how verification limits are calculated, assume you are testing the unit using a 10V output value. Using the Model 2306 voltage output accuracy specification of $\pm(0.05\%$ of output + 3mV offset), the calculated output limits are:

$$\text{Output limits} = 10\text{V} \pm [(10\text{V} \times 0.05\%) + 3\text{mV}]$$

$$\text{Output limits} = 10\text{V} \pm (0.005 + 0.003)$$

$$\text{Output limits} = 10\text{V} \pm 0.008\text{V}$$

$$\text{Output limits} = 9.992\text{V to } 10.008\text{V}$$

Performing the verification test procedures

Test summary

- DC voltage output accuracy
- DC voltage readback accuracy
- DC current output accuracy
- DC current readback accuracy
- Digital voltmeter input accuracy

If the Model 2306 is not within specifications and out of warranty, see the calibration procedures in Section 13 for information on calibrating the unit.

Test considerations

When performing the verification procedures:

- Make sure that the test equipment is properly warmed up and connected to the correct Model 2306 OUTPUT #1 or OUTPUT #2 terminals on the rear panel, as appropriate for the channel you are testing.
- Before setting output values, select Channel #1 (battery channel) or Channel #2 (charger channel) as required. Press the ◀ and ▶ keys to toggle between Channel #1 (OUTPUT #1 terminals) and Channel #2 (OUTPUT #2 terminals).
- Be sure the test equipment is set up for the proper function and range.
- Do not connect test equipment to the Model 2306 through a scanner, multiplexer, or other switching equipment.
- Be sure that the Model 2306 output is turned on before making measurements.
- Allow the unit output signal to settle before making a measurement.

Output voltage accuracy

Follow the steps below to verify that Model 2306 output voltage accuracy is within specified limits. This test involves setting the output voltage to specific values and measuring the voltages with a precision digital multimeter.

1. With the power supply's output off, connect the digital multimeter to the Model 2306 OUTPUT #1 SOURCE and SENSE terminals, as shown in Figure 12-1. Be sure to observe proper polarity (SOURCE + and SENSE + to INPUT HI; SOURCE - and SENSE - to INPUT LO).

Figure 12-1
Connections for voltage verification tests

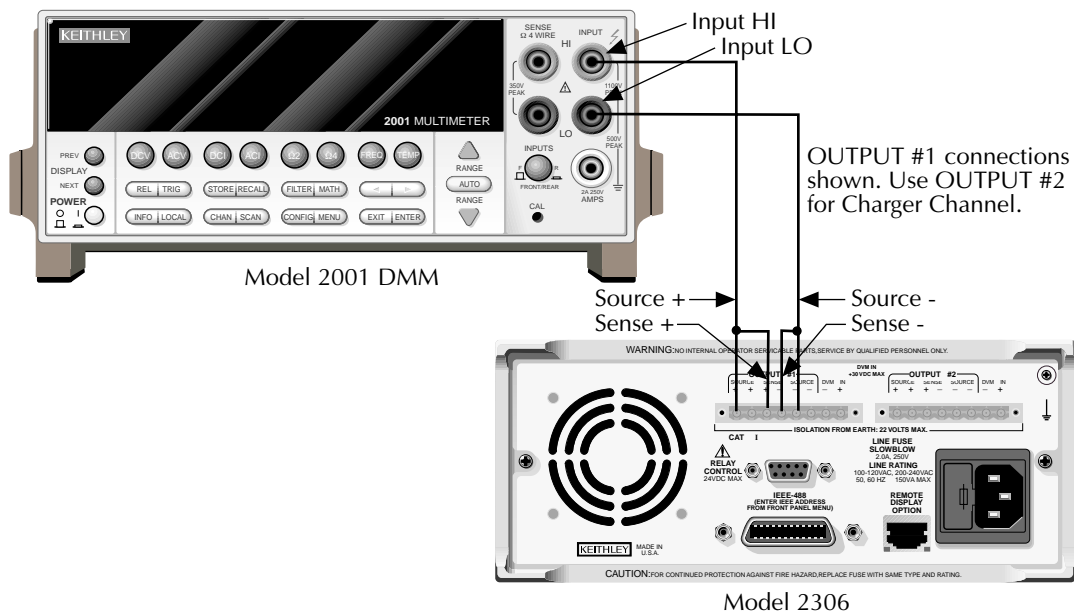

2. Select the multimeter DC volts measuring function, and enable auto-ranging.
3. Select Channel #1 by pressing the ◀ and ▶ keys to toggle between Channel #1 and Channel #2. Make sure the Model 2306 output is turned on.
4. Verify output voltage accuracy for each of the voltages listed in Table 12-2. For each test point:
 - Set the Model 2306 output voltage to the indicated value.
 - A value of current compliance of 0.25A is sufficient.
 - Allow the reading to settle.
 - Verify that the multimeter reading is within the limits given in the table.
5. Repeat steps 1 through 4 for Channel #2 (use the ◀ and ▶ keys to toggle between Channel #1 and Channel #2).

Table 12-2
Output voltage accuracy limits

Model 2306 output voltage setting	Output voltage limits (2 Years, 18°C-28°C)
5.00V	4.9945 to 5.0055V
10.00V	9.992 to 10.008V
15.00V	14.9895 to 15.0105V

Voltage readback accuracy

Follow the steps below to verify that Model 2306 voltage readback accuracy is within specified limits. The test involves setting the source voltage to specific values, as measured by a digital multimeter, and then verifying that voltage readback readings are within required limits.

1. With the power supply's output off, connect the digital multimeter to the Model 2306 OUTPUT #1 SOURCE and SENSE terminals, as shown in Figure 12-1. Be sure to observe proper polarity (SOURCE + and SENSE + to INPUT HI; SOURCE - and SENSE - to INPUT LO).
2. Select the multimeter DC volts function, and enable auto-ranging.
3. Select Channel #1 by pressing the ◀ and ▶ keys to toggle between Channel #1 and Channel #2. Make sure actual voltage readings are being displayed (use DISPLAY), and turn on the Model 2306 output.
4. Verify voltage readback accuracy for each of the voltages listed in Table 12-3 on page 12-7. For each test point:
 - Set the Model 2306 output voltage to the indicated value as measured by the digital multimeter. If it is not possible to set the voltage source precisely to the specified value, use the closest possible setting and modify reading limits accordingly.
 - Set compliance current to 0.25A (or 250mA).
 - Allow the reading to settle.
 - Verify that the actual Model 2306 voltage reading is within the limits given in the table.
5. After changing connections to OUTPUT #2, repeat steps 1 through 4 for Channel #2 (use the ◀ and ▶ keys to toggle between Channel #1 and Channel #2).

Table 12-3
Voltage readback accuracy limits

Model 2306 output Voltage setting ¹	Voltage readback limits (2 Years, 18°C-28°C)
5.00V	4.995 to 5.005V
10.00V	9.992 to 10.008V
14.00V	13.990 to 14.010V

¹As measured by digital multimeter.

Compliance current accuracy

Follow the steps below to verify that Model 2306/2306-PJ compliance current accuracy is within specified limits. The test involves setting the compliance current to specific values and determining the actual current by measuring the voltages across a characterized 1Ω resistor with a precision digital multimeter.

1. With the power supply's output off, connect the digital multimeter and characterized 1Ω resistor to the Model 2306 OUTPUT #1 SOURCE terminals, as shown in Figure 12-2. Be sure to observe proper polarity (SOURCE + to INPUT HI; SOURCE - to INPUT LO). Be sure to use 4-wire connections to the resistor terminals.

Figure 12-2
Connections for output current and 5A range current verification tests

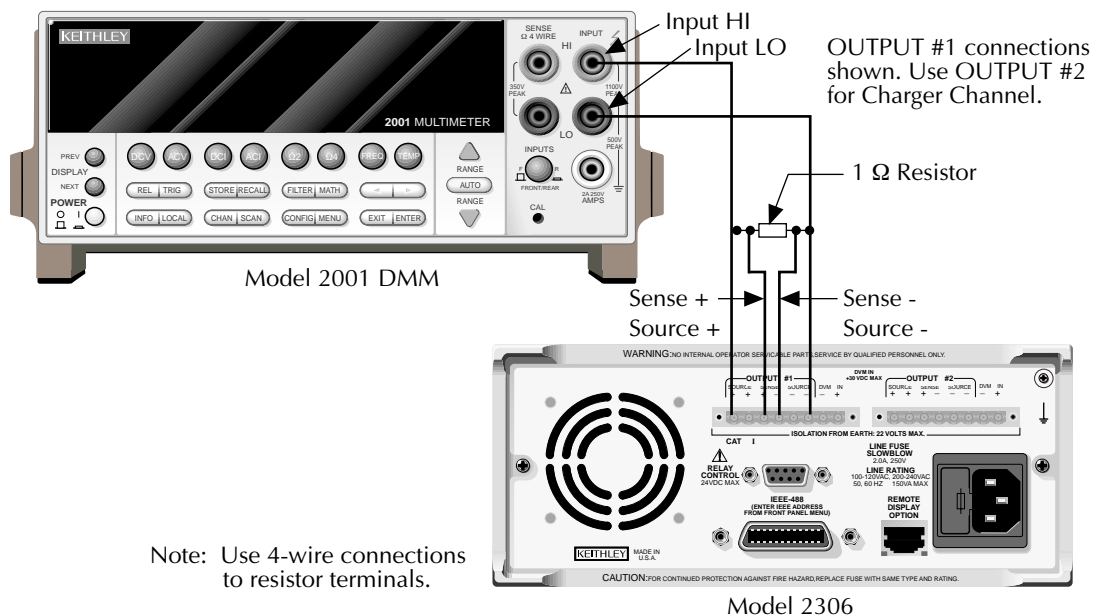

Model 2306

2. Select the multimeter DC voltage measuring function, and enable auto-ranging.
3. Select Channel #1 by pressing the ◀ and ▶ keys to toggle between Channel #1 and Channel #2. Turn on the Model 2306 output.
4. Verify compliance current accuracy for the currents listed in Table 12-4. For each test point:
 - Set the Model 2306 output voltage to 8V, and set the compliance current to the value being tested.
 - Note and record the digital multimeter voltage reading.
 - Calculate the current from the voltage reading and actual 1Ω resistor value: $I = V/R$.
 - Verify that the current is within the limits given in the table.
5. Repeat steps 1 through 4 for Channel #2 (use the ◀ and ▶ keys to toggle between Channel #1 and Channel #2).

Table 12-4
Compliance current accuracy limits

Model 2306 compliance current setting	Compliance current limits (2 Years, 18°C-28°C)
1.000A	0.993 to 1.007A
2.000A	1.992 to 2.008A
3.000A	2.990 to 3.010A
4.000A	3.989 to 4.011A
4.500A	4.488 to 4.512A

Current readback accuracy

Follow the steps below to verify that Model 2306 current readback accuracy is within specified limits. The test involves setting the output current to specific values as measured with a resistor and precision digital multimeter.

5A range readback accuracy

1. With the power supply's output off, connect the digital multimeter and characterized 1Ω resistor to the Model 2306 OUTPUT #1 SOURCE terminals, as shown in Figure 12-2. Be sure to observe proper polarity (SOURCE + to INPUT HI; SOURCE - to INPUT LO). Be sure to use 4-wire connections to the resistor terminals.
2. Select the multimeter DC volts measuring function, and enable auto-ranging.
3. Select Channel #1 by pressing the ◀ and ▶ keys to toggle between Channel #1 and Channel #2, and select the 5A readback range. Also make sure actual current readings are displayed.
4. Turn on the Model 2306 output.

5. Verify 5A range current readback accuracy for the currents listed in Table 12-5. For each test point:
 - By changing the output voltage, adjust the current to the correct value, *as determined from the multimeter voltage reading and characterized resistance value*. When setting the voltage, be sure to set the compliance current to 5A.
 - Note that it may not be possible to set the output current to the exact value. Set the current to the closest possible value, and modify reading limits accordingly.
 - Allow the reading to settle.
 - Verify that the actual Model 2306 current reading is within the limits given in the table.
6. After changing connections to OUTPUT #2, repeat steps 1 through 5 for Channel #2 (use the ◀ and ▶ keys to toggle between Channel #1 and Channel #2).

Table 12-5

5A range current readback accuracy limits

Nominal output Voltage	Model 2306 Output current ¹	Current readback limits (2 Years, 18°C-28°C)
1V	1.000A	0.9978–1.0022A
2V	2.000A	1.9958–2.0042A
3.000A	3.000A	2.9938–3.0062A
4V	4.000A	3.9918–4.0082A
4.5V	4.500A	4.4908–4.5092A

¹As determined from digital multimeter voltage reading and 1Ω resistor.

5mA range readback accuracy

The following test applies to the Model 2306 and 2302 (not applicable for Models 2306-PJ or 2302-PJ).

1. With the power supply's output off, connect the digital multimeter and characterized 3kΩ resistor to the Model 2306 OUTPUT #1 terminals, as shown in Figure 12-3. Be sure to observe proper polarity and connections (3kΩ resistor between SOURCE + and DMM INPUT HI; SOURCE - to DMM INPUT LO).

Figure 12-3
Connections for 5mA current verification tests

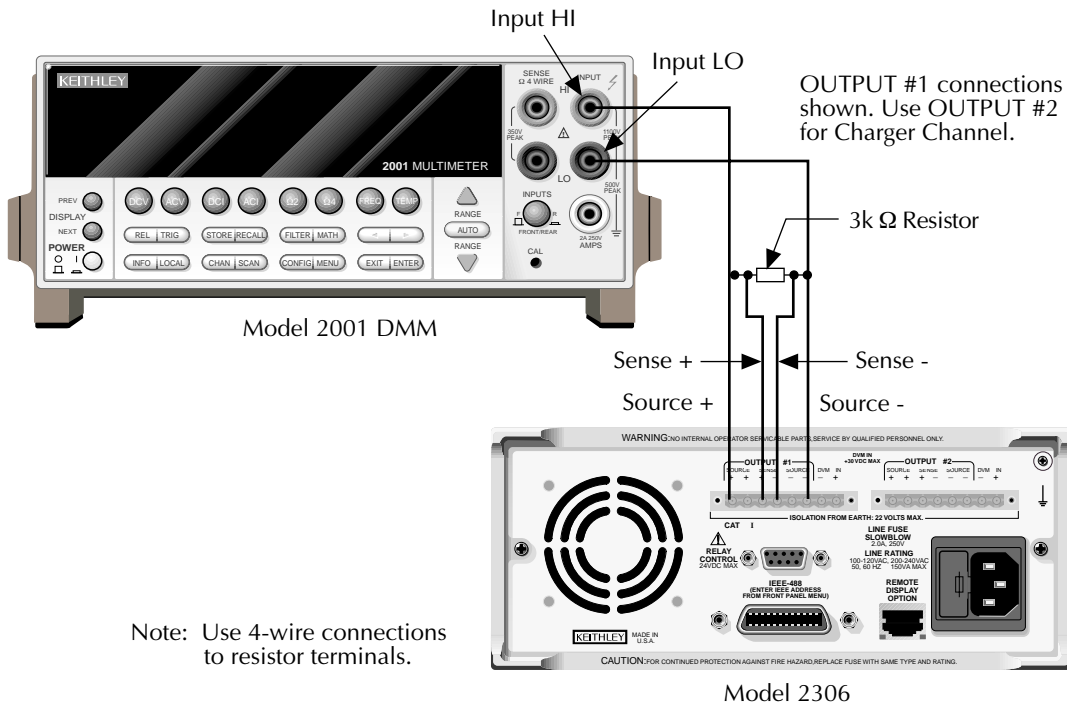

2. Select the multimeter DC volts measuring function, and enable auto-range.
3. Select Channel #1 by pressing the ◀ and ▶ keys to toggle between Channel #1 and Channel #2, then select the 5mA readback range and actual current reading data.
4. Turn on the Model 2306 output.
5. Verify 5mA range current readback accuracy for the currents listed in Table 12-6. For each test point:
 - Set the Model 2306 output current to the correct value, *as determined from the digital multimeter voltage reading and 3k Ω resistance value*. Note that it may not be possible to set the output current to the exact value. In that case, set the current to the closest possible value, and modify reading limits accordingly.
 - Allow the reading to settle.
 - Verify that the actual Model 2306 current reading is within the limits given in the table.
6. Repeat steps 1 through 5 for Channel #2 (use the ◀ and ▶ keys to toggle between Channel #1 and Channel #2).

Table 12-6
5mA range current readback accuracy limits

Nominal output Voltage	Model 2306 output current ¹	Current readback limits (2 Years, 18°C-28°C)
3V	1.0000mA	0.9970 to 1.0030mA
6V	2.0000mA	1.9950 to 2.0050mA
9V	3.0000mA	2.9930 to 3.0070mA
12V	4.0000mA	3.9910 to 4.0090mA
14.7V	4.9000mA	4.8892 to 4.9108mA

¹As determined from digital multimeter voltage reading and 3k Ω resistance value.

500mA range readback accuracy

1. With the power supply's output off, connect the digital multimeter and characterized 30 Ω resistor to the Model 2306-PJ OUTPUT #1 terminals, as shown in Figure 12-4. Be sure to observe proper polarity and connections (30 Ω resistor between SOURCE + and DMM INPUT HI; SOURCE - to DMM INPUT LO).

Figure 12-4
Connections for 500mA current verification tests

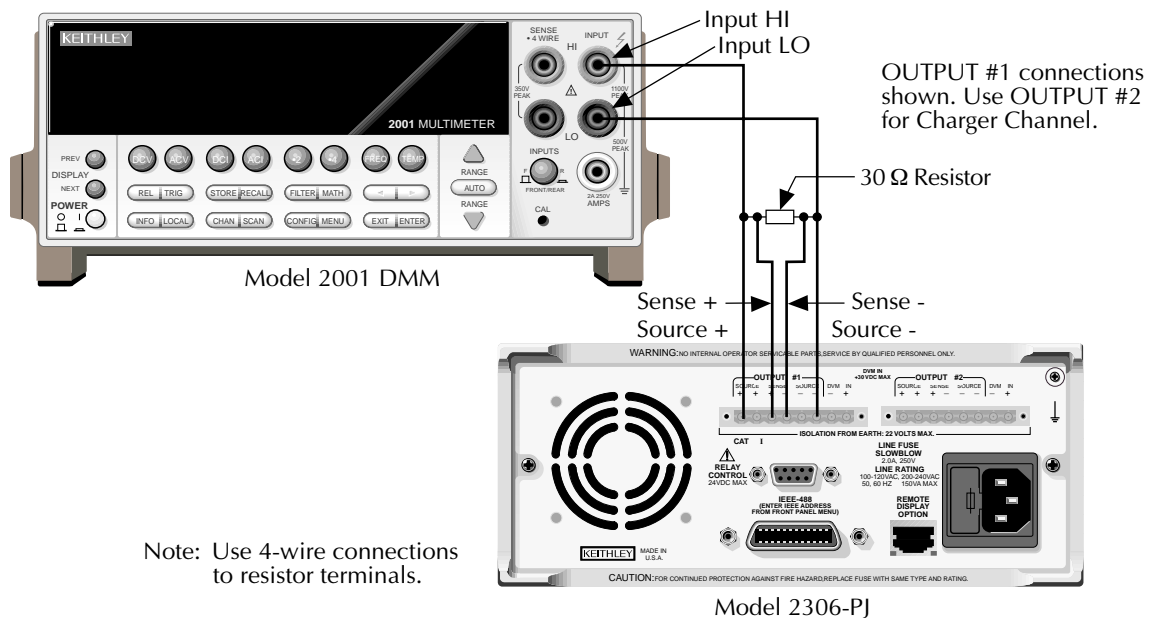

2. Select the multimeter DC volts measuring function, and enable auto-range.
3. Select Channel #1 by pressing the ◀ and ▶ keys to toggle between Channel #1 and Channel #2, then select the 500mA readback range and actual current reading data.
4. Turn on the Model 2306-PJ output.
5. Verify 5mA range current readback accuracy for the currents listed in Table 12-7. For each test point:
 - Set the Model 2306-PJ output current to the correct value, *as determined from the digital multimeter voltage reading and 30Ω resistance value*. Note that it may not be possible to set the output current to the exact value. In that case, set the current to the closest possible value, and modify reading limits accordingly.
 - Allow the reading to settle.
 - Verify that the actual Model 2306-PJ current reading is within the limits given in the table.

Table 12-7
500mA range current readback accuracy limits

Nominal output Voltage	Model 2306 output current ¹	Current readback limits (2 Years, 18°C-28°C)
3V	100.00mA	99.76 to 100.24mA
6V	200.00mA	199.56 to 200.44mA
9V	300.00mA	299.36 to 300.64mA
12V	400.00mA	399.16 to 400.84mA
14.7V	490.00mA	488.98 to 491.02mA

¹As determined from digital multimeter voltage reading and 30Ω resistance value.

Digital voltmeter input accuracy

Follow the steps below to verify that Model 2306 digital voltmeter input accuracy is within specified limits. The test involves setting the voltage applied to the DVM input to accurate values and then verifying that the Model 2306 digital voltmeter input readings are within required limits.

1. With the power supply's output off, connect the Model 2306 OUTPUT #1 DVM IN, SOURCE, and SENSE terminals to the digital multimeter, as shown in Figure 12-5. Be sure to observe proper polarity (DVM IN +, SOURCE + and, SENSE + to DMM INPUT HI; also DVM IN -, SOURCE -, and SENSE - to DMM INPUT LO).

Figure 12-5
Connections for DVM accuracy verification

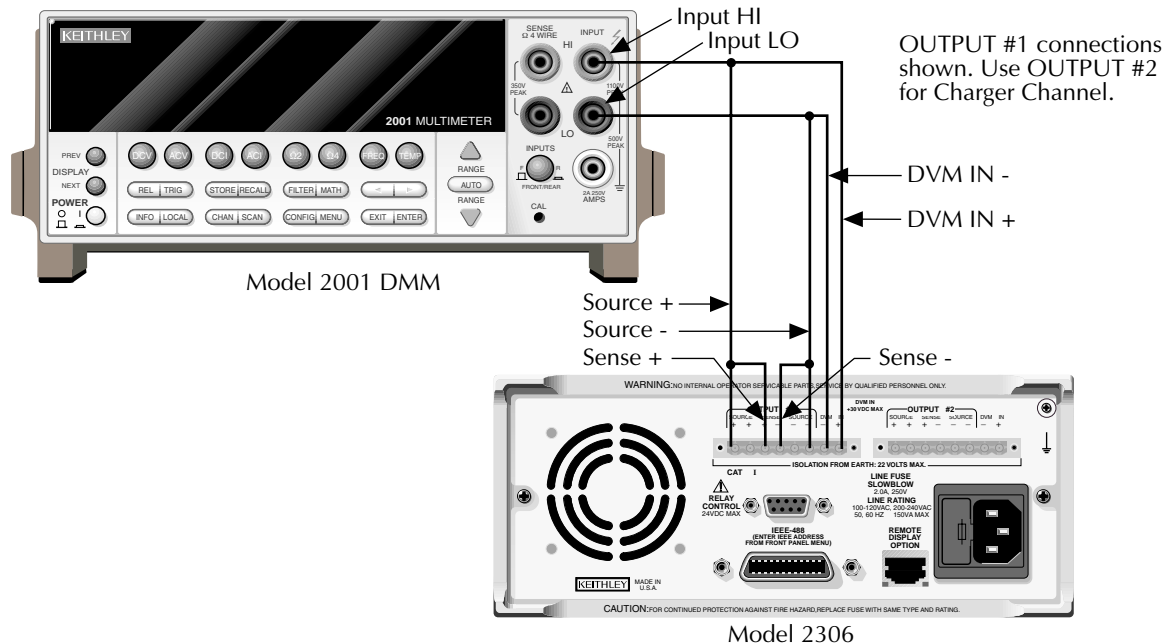

2. Select the DMM DC volts function, and enable auto-ranging.
3. Select Channel #1 by pressing the ◀ and ▶ keys to toggle between Channel #1 and Channel #2, and enable the Model 2306 DVM input.
4. Turn on the Model 2306 source output.
5. Verify digital voltmeter input accuracy for each of the voltages listed in Table 12-8. For each test point:
 - Set the voltage to the indicated value as measured by the digital multimeter.
 - Set current compliance to 0.25A.
 - Allow the reading to settle.
 - Verify that the Model 2306 voltage reading is within the limits given in the table.

- Repeat steps 1 through 5 for Channel #2 (use the ◀ and ▶ keys to toggle between Channel #1 and Channel #2).

Table 12-8*Digital voltmeter input accuracy limits*

Model 2306 output Voltage setting¹	Digital voltmeter input reading limits (2 Years, 18°C-28°C)
5.00V	4.995 to 5.005V
10.00V	9.992 to 10.008V
14.00V	13.990 to 14.010V

¹As measured by digital multimeter.

13

Calibration

NOTES *This manual covers Keithley Models 2302, 2302-PJ, 2306, and 2306-PJ simulators (power supplies). Since the Model 2302 and 2302-PJ are single channel battery simulators, functions related to the second channel (i.e., the charger channel) are not available for the Model 2302 and 2302-PJ. Therefore:*

- *battery and charger channel features contained in this manual apply for the Model 2306 and 2306-PJ*
- *only battery channel features contained in this manual apply for the Model 2302 and 2302-PJ*

Refer to Appendix F for specific Model 2302 and 2302-PJ information.

Information contained in this section applies to all power supply channels (unless otherwise noted). In this manual, channel 1 refers to the battery channel while channel 2 refers to the charger channel (2306 and 2306-PJ feature only).

Introduction

Use the procedures in this section to calibrate the Model 2306. These procedures require accurate test equipment to measure precise DC voltages and currents. Calibration can be performed either from the front panel or by sending SCPI calibration commands over the IEEE-488 bus with the aid of a computer.

WARNING The information in this section is intended only for qualified service personnel. Do not attempt these procedures unless you are qualified to do so.

Environmental conditions

Temperature and relative humidity

Conduct the calibration procedures at an ambient temperature of 18-28°C (65-82°F) with a relative humidity of less than 70% unless otherwise noted.

Warm-up period

Allow the Model 2306 to warm up for at least one hour before performing calibration.

If the instrument has been subjected to temperature extremes (those outside the ranges stated above), allow additional time for the instrument's internal temperature to stabilize. Typically, allow one extra hour to stabilize a unit that is 10°C (18°F) outside the specified temperature range.

Allow the test equipment to warm up for the minimum time specified by the manufacturer.

Line power

The Model 2306 requires a line voltage of 100 to 240V at line frequency of 50 or 60Hz. The instrument must be calibrated while operating from a line voltage within this range.

Calibration considerations

When performing the calibration procedures:

- Make sure that the test equipment is properly warmed up and connected to the appropriate Model 2306 OUTPUT #1 or OUTPUT #2 terminals, depending on which channel you are calibrating.
- Always allow the source signal to settle before calibrating each point.
- Do not connect test equipment to the Model 2306 through a scanner or other switching equipment.
- Calibration must be performed in the sequence outlined in this manual or an error will occur.
- Both channels are calibrated during calibration.

- If an error occurs during calibration, the Model 2306 will generate an appropriate error message. See Appendix C for more information.

WARNING The maximum common-mode voltage (voltage between LO and chassis ground) is 22VDC. Exceeding this value may cause a breakdown in insulation, creating a shock hazard.

Calibration cycle

Perform calibration at least once every two years to ensure the unit meets or exceeds its specifications.

Recommended calibration equipment

Table 13-1 lists the recommended equipment for the calibration procedures. You can use alternate equipment as long as that equipment has specifications at least four times better than corresponding Model 2306 specifications. See also “Resistor considerations” later in this section for important temperature coefficient information.

Table 13-1
Recommended calibration equipment

Description	Manufacturer/Model	Specifications
Digital Multimeter	Keithley 2001	DC Voltage ¹ 20V: ± 22 ppm Resistance ¹ 20 Ω : ± 59 ppm 20k Ω : ± 36 ppm
Precision Resistor		4 Ω , 0.1%, 100W ²
Precision Resistor		3k Ω , 0.1%, 0.125W ²

¹Full-range, 90-day, 23°C $\pm 5^\circ$ C accuracy specifications of ranges required for various measurement points.

²Characterize resistor using 4-wire ohms function of DMM before use.

Resistor connections

When performing calibration steps that use either the 4 Ω or 3k Ω resistor, connect the Model 2306 OUTPUT #1 or OUTPUT #2 SENSE leads and DMM test leads as close to the resistor body as possible.

Resistor considerations

The test resistors should be characterized using the 4-wire ohms function of the DMM recommended in Table 13-1 to measure the resistance values. Use the measured resistance values to calculate the actual currents during the calibration procedures.

NOTE The temperature coefficient and temperature change of the 4Ω resistor when passing current at full load must be low enough so that the change in resistance does not cause incorrect readings. This is summarized in the following equation:

$$\frac{V_{OUT}}{(R + \Delta R)} < 25\% \text{ of Model 2306 amps specification}$$

where: V_{OUT} is the Model 2306 output voltage
 R is the characterized value of the resistor
 ΔR is the change in resistance caused by heating

Front panel calibration

Use the following procedure to calibrate the Model 2306 from the front panel. Table 13-2 summarizes calibration steps.

NOTE Calibration must be performed in the following sequence, or an error will occur. To abort calibration and revert to previous calibration constants at any time during the procedure, press the MENU key. Follow message prompts to abort calibration. Use ▲ and ▼ keys to select desired response.

Step 1: Prepare the Model 2306 for calibration

1. Turn on the Model 2306 and the digital multimeter, and allow them to warm up for at least one hour before performing calibration.
2. Press the MENU key, then choose CALIBRATE UNIT, and press ENTER. The instrument will display the date last calibrated:

```
CALIBRATE UNIT
LAST ON 02/01/98
```

3. Press the ▲ key. The instrument will display the number of times it was calibrated:

```
CALIBRATE UNIT
TIMES = 1
```

4. Press the ▲ key. The unit will then prompt you to run calibration:

```
CALIBRATE UNIT
RUN
```

5. Press ENTER. The unit will then prompt for the calibration code:

```
CALIBRATE UNIT
Cal Code KI002306
```

6. Using the edit keys, set the display to the current calibration code, then press ENTER. (Default: KI002306.) The unit will then prompt you as to whether or not to change the code:

CALIBRATE UNIT

Change Code NO

7. Be sure NO is selected (use the ▲ and ▼ keys), press ENTER, then follow the steps below to calibrate the unit. (See Changing the calibration code at the end of this section if you wish to change the code.)

Figure 13-1
Connections for voltage calibration

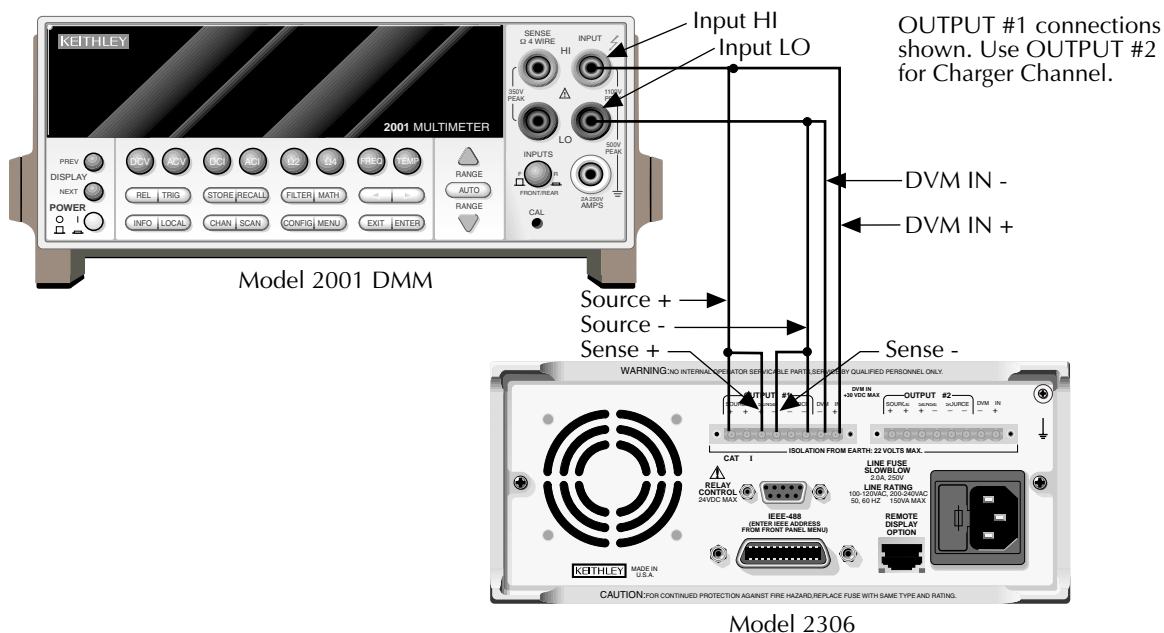

Step 2: Perform Channel #1 (battery channel) calibration steps

NOTE The unit will display the most recently calibrated values. Factory defaults are shown in this manual.

1. Connect the OUTPUT #1 SOURCE, SENSE, and DVM IN terminals to the DMM, as shown in Figure 13-1.

DMM Input connections:

HI: SOURCE +, SENSE +, and DVM IN +

LO: SOURCE -, SENSE -, and DVM IN -

2. At this point, the Model 2306 will prompt you to set the full-scale Channel #1 output voltage:

```
CAL VOLTS CHAN 1
SET 14.0000 V
```

3. Use the edit keys to set the voltage to 14.0000V, then press ENTER.

NOTE *At this point, the source output is turned on and will remain on until calibration is complete or aborted with the MENU key.*

4. The unit will prompt you for the DMM reading, which will be used to calibrate the Channel #1 full-scale output voltage:

```
CAL VOLTS CHAN 1
READ1 14.0000 V
```

5. Using the edit keys, adjust the Model 2306 voltage display to agree with the DMM voltage reading, then press ENTER. The unit will then prompt for another DMM reading, which will be used to calibrate the full-scale Channel #1 measurement function:

```
CAL VOLTS CHAN 1
READ2 14.0000 V
```

6. Using the edit keys, adjust the display to agree with the new DMM voltage reading, then press ENTER. The unit will prompt for Channel #1 DVM full-scale calibration:

```
CAL DVM CHAN 1
ALL READY TO DO?
```

7. Press ENTER to complete Channel #1 DVM full-scale calibration.
8. Connect the digital multimeter volts input and characterized 4Ω resistor to the Model 2306 OUTPUT #1 SOURCE terminals, as shown in Figure 13-2. Be sure to observe proper polarity (SOURCE + to DMM INPUT HI; SOURCE - to INPUT LO).
9. Be sure the digital multimeter DC volts function and auto-ranging are still selected.
10. At this point, the unit will prompt for 5A Channel #1 full-scale calibration output:

```
CAL 5 A CHAN 1
SET 1.90000 A
```

11. Using the edit keys, adjust the set value to 1.9000A, then press ENTER. The unit will prompt you for the DMM reading, which calibrates the 5A current limit for Channel #1:

```
CAL 5 A CHAN 1
READ1 1.90000 A
```

12. Note the DMM voltage reading, then calculate the current from that reading and the actual 4Ω resistance value: $I = V/R$. Adjust the Model 2306 current display value to agree with the calculated current value, and press ENTER.

Figure 13-2
Connections for 5A/500mA current calibration

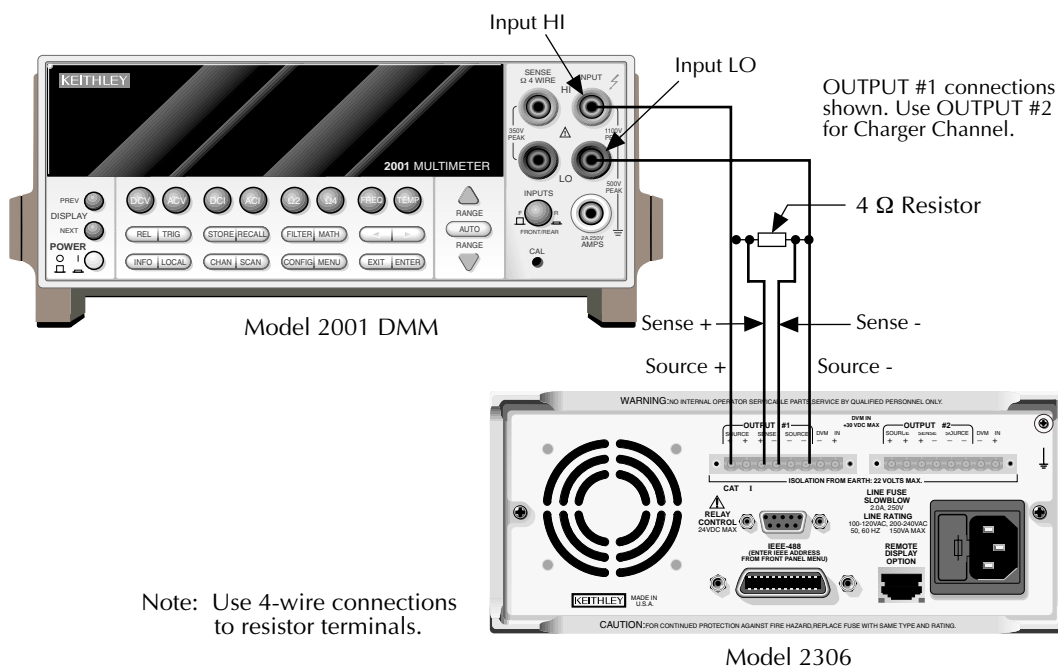

Note: Use 4-wire connections to resistor terminals.

13. The Model 2306 will prompt for another DMM reading, which is used for 5A measurement calibration of Channel #1:

```
CAL 5 A CHAN 1
            READ2 1.90000 A
```
14. Again, calculate the current from the new DMM reading and 4Ω resistor value. Adjust the 2306 current display reading to agree with the new current, then press ENTER.
15. *For Model 2306:* Connect the 3kΩ resistor in place of the 4Ω resistor (Figure 13-3).
For Model 2306-PJ: Leave the 4Ω resistor in place (do not change resistors) (Figure 13-2).
16. At this point, the unit will prompt for an output on Channel #1.

<i>For Model 2306:</i>	<i>For Model 2306-PJ:</i>
CAL 5 mA CHAN 1	CAL 500 mA CHAN 1
ALL READY TO DO?	ALL READY TO DO?
17. *For Model 2306:* Press ENTER to output approximately 5mA.
For Model 2306-PJ: Press ENTER to output approximately 500mA.
18. The unit will then prompt you for the DMM reading:

<i>For Model 2306:</i>	<i>For Model 2306-PJ:</i>
CAL 5 mA CHAN 1	CAL 500 mA CHAN 1
READ1 4.50000 mA	READ1 450.000 mA

Figure 13-3
Connections for 5mA range calibration

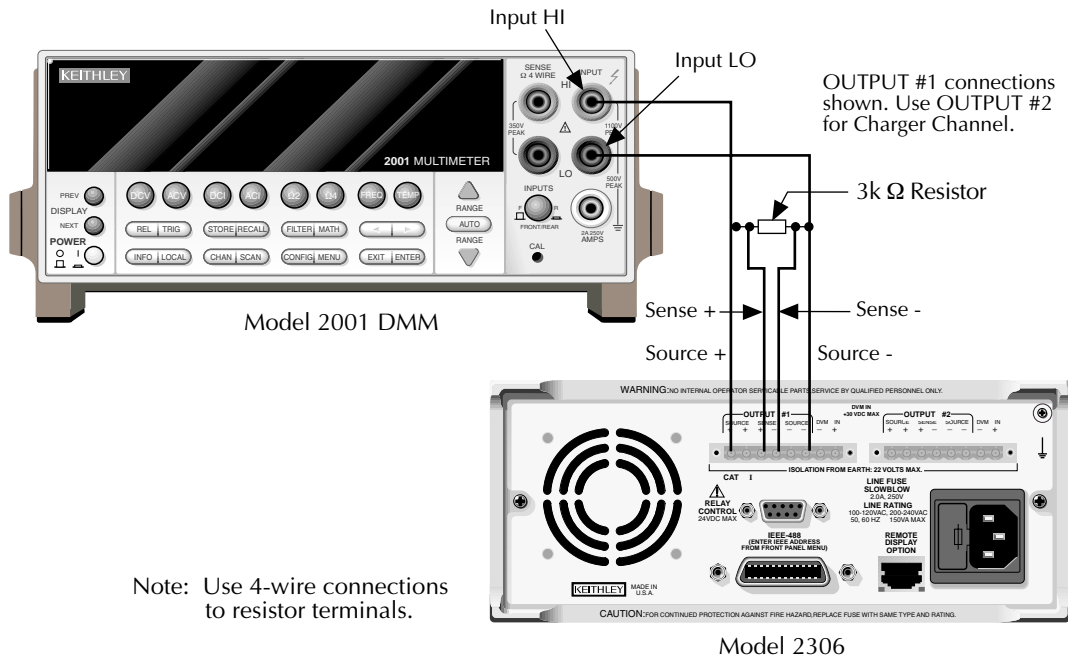

19. Note the DMM voltage reading, then calculate the current from that voltage reading and actual resistance value. Adjust the Model 2306 current display value to agree with that value, and press ENTER.

Step 3: Perform Channel #2 (charger channel) calibration steps

1. Connect the OUTPUT #2 SOURCE, SENSE, and DVM IN terminals to the DMM. Use the same general connections shown in Figure 13-1 except make all connections to the OUTPUT #2 terminals.

DMM input connections:

HI: SOURCE +, SENSE +, and DVM IN +

LO: SOURCE -, SENSE -, and DVM IN -

2. The Model 2306 will prompt you to set the full-scale Channel #2 output voltage:

```
CAL VOLTS CHAN 2
```

```
SET 14.0000 V
```

3. Use the edit keys to set the voltage to 14.0000V, then press ENTER.
4. The unit will prompt you for the DMM reading, which will be used to calibrate the Channel #2 full-scale output voltage:

```
CAL VOLTS CHAN 2
```

```
READ1 14.0000 V
```

Table 13-2
Model 2306 front panel calibration summary

Steps ¹	Description	Nominal calibration signal ²	Test connections
0, 9	Output 14V	14V	Figure 13-1 on page 13-5
1, 10	Full-scale output voltage	14V	Figure 13-1 on page 13-5
2, 11	Full-scale measure	14V	Figure 13-1 on page 13-5
3, 12	Full-scale DVM	14V	Figure 13-1 on page 13-5
4, 13	5A range output current	1.9A	on page 13-7
5, 14	5A current limit	1.9A	on page 13-7
6, 15	5A measure	1.9A	on page 13-7
7	Model 2306: 5mA range output current Model 2306-PJ: 500mA range output current	4.5mA 450mA	
8	Model 2306: 5mA measure Model 2306-PJ: 500mA measure	4.5mA 450mA	
16	5mA range output current	4.5mA	on page 13-8
17	5mA measure	4.5mA	on page 13-8

¹ Step numbers correspond to :CAL:PROT:STEP command numbers. See Table 13-3.

Steps 0 - 8 calibrate Channel #1 (Battery Channel). Steps 9 - 17 calibrate Channel #2 (Charger Channel).

² Factory default display values shown.

- Using the edit keys, adjust the Model 2306 voltage display to agree with the DMM voltage reading, then press ENTER. The unit will prompt for another DMM reading, which will be used to calibrate the full-scale Channel #1 measurement function:

```
CAL VOLTS CHAN 2
READ2 14.0000 V
```

- Using the edit keys, adjust the display to agree with the new DMM voltage reading, then press ENTER. The unit will prompt for Channel #2 DVM full-scale calibration:

```
CAL DVM CHAN 2
ALL READY TO DO?
```

- Press ENTER to complete Channel #2 DVM full-scale calibration.

8. Connect the digital multimeter volts input and characterized 4Ω resistor to the Model 2306 OUTPUT #2 SOURCE terminals using the same general connections shown in Figure 13-2. Be sure to observe proper polarity (SOURCE + to DMM INPUT HI; SOURCE - to INPUT LO).
9. Be sure the digital multimeter DC volts function and auto-ranging are still selected.
10. At this point, the unit will prompt for 5A Channel #2 full-scale calibration output:
CAL 5 A CHAN 2
SET 1.90000 A
11. Using the edit keys, adjust the set value to 1.9000A, then press ENTER. The unit will prompt you for the DMM reading, which calibrates the Channel #2 5A current limit:
CAL 5 A CHAN 2
READ1 1.90000 A
12. Note the DMM voltage reading, then calculate the current from that reading and the actual 4Ω resistance value: $I = V/R$. Adjust the Model 2306 current display value to agree with the calculated current value, and press ENTER.
13. The Model 2306 will prompt for another DMM reading, which is used for Channel #2 5A measurement calibration:
CAL 5 A CHAN 2
READ2 1.90000 A
14. Again, calculate the current from the new DMM reading and 4Ω resistor value. Adjust the 2306 current display reading to agree with the new current, then press ENTER.
15. Disconnect the 4Ω resistor, then connect the $3k\Omega$ resistor in its place. (Use the connections in Figure 13-3 except make connections to the OUTPUT #2 terminals.)
16. Make sure the DMM DC volts function and auto-ranging are still selected.
17. At this point, the unit will prompt to output approximately 5mA for Channel #2 5mA range full-scale calibration:
CAL 5 mA CHAN 2
ALL READY TO DO?
18. Press ENTER to output approximately 5mA. The unit will then prompt you for the DMM reading:
CAL 5 mA CHAN 2
READ1 4.50000 mA
19. Note the DMM voltage reading, then calculate the current from that voltage reading and actual $3k\Omega$ resistance value. Adjust the Model 2306 current display value to agree with that value and press ENTER.

Step 4: Enter calibration dates, and save calibration

1. After completing all Channel #1 and Channel #2 calibration steps, the unit will prompt if you wish to save calibration:

```
CALIBRATE UNIT
```

```
Save Cal Data YES
```

2. To save new calibration constants, select YES, then press ENTER. If you wish to exit calibration without saving new calibration constants, select NO, then press ENTER. In that case, the unit will revert to prior calibration constants.
3. The unit will then prompt you to enter the calibration date:

```
CALIBRATE UNIT
```

```
Cal Date 02/01/98
```

4. Using the edit keys, set the calibration date to today's date, then press ENTER. The unit will display the following:

```
CALIBRATE UNIT
```

```
EXITING CAL
```

5. Press ENTER to complete the calibration procedure and return to the menu display. Calibration is now complete.

Remote calibration

Follow the procedure outlined below to perform Model 2306 remote calibration by sending SCPI commands over the IEEE-488 bus. The remote commands and appropriate parameters are separately summarized for each step.

Remote calibration display

The Model 2306 will display the following while being calibrated over the bus:

```
CALIBRATING UNIT
```

```
FROM THE BUS R
```

NOTE The "R" located on the lower right hand corner of the display indicates remote operation.

Remote calibration procedure

Use the following procedure to calibrate the Models 2306. Table 13-3 summarizes the calibration steps in the proper sequence. See Appendix C for command details.

NOTES Calibration steps must be performed in the following sequence, or an error will occur. You can abort the procedure and revert to previous calibration constants before :SAVE by sending the :CAL:PROT:LOCK command.

Calibration is performed on both channels at the same time — it is not possible to only calibrate one channel.

Step 1: Prepare the Model 2306 for calibration

1. Connect the Model 2306 to the controller IEEE-488 interface using a shielded interface cable.
2. Turn on the Model 2306 and the test equipment, and allow them to warm up for at least one hour before performing calibration.
3. Make sure the IEEE-488 primary address of the Model 2306 is the same as the address specified in the program you will be using to send commands.
4. Send the following command with the correct code to unlock calibration:

```
:CAL:PROT:CODE `code`
```

For example, with the factory default code of KI002306, send:

```
CAL:PROT:CODE `KI002306`
```

5. Send the following command to initiate calibration:

```
:CAL:PROT:INIT
```

Step 2: Perform Channel #1 (battery channel) calibration steps

NOTE Allow the Model 2306 to complete each calibration step before going on to the next one. See Detecting calibration step completion in Appendix C.

1. Connect the OUTPUT #1 SOURCE, SENSE, and DVM IN terminals to the digital multimeter, as shown in Figure 13-1. (Connect SOURCE +, SENSE +, and DVM IN + to DMM INPUT HI; SOURCE -, SENSE -, and DVM IN - to DMM INPUT LO.)
2. Send the following command to output 14V:

```
:CAL:PROT:STEP0 14
```

NOTE At this point, the source output is turned on and will remain on until calibration is completed or aborted with the :CAL:PROT:LOCK command.

3. Note and record the DMM reading, then send that reading as the parameter for the following command:

```
:CAL:PROT:STEP1 DMM_Reading
```

For example, if the DMM reading is 14.012V, the command would be:

```
:CAL:PROT:STEP1 14.012
```

4. Note and record a new DMM reading, then send that reading as the parameter for the following command:

```
:CAL:PROT:STEP2 DMM_Reading
```

5. Send the following command for DVM full-scale calibration:

```
:CAL:PROT:STEP3
```

6. Connect the Model 2306 OUTPUT #1 SOURCE terminals to the DMM volts input and characterized 4Ω resistor, as shown in Figure 13-2. Be sure to observe proper polarity (SOURCE + to INPUT HI; SOURCE - to INPUT LO).
7. Make sure the digital multimeter DC volts function and auto-ranging are still selected.
8. Send the following command to output 1.9A for 5A full-scale calibration:

```
:CAL:PROT:STEP4 1.9
```

9. Note and record the DMM voltage reading, then calculate the current from that reading and characterized 4Ω resistor value. Send the following command using that calculated current as the parameter:

```
:CAL:PROT:STEP5 <Calculated_Current>
```

For example, with a current value of 1.894A, the command would appear as follows:

```
:CAL:PROT:STEP5 1.894
```

10. Note and record a new DMM voltage reading, then again calculate the current from the voltage and resistance. Send the calculated current value as the parameter for the following command:

```
:CAL:PROT:STEP6 <Calculated_Current>
```

11. *For Model 2306:* Connect the $3k\Omega$ resistor in place of the 4Ω resistor (Figure 13-3).
For Model 2306-PJ: Leave the 4Ω resistor in place (do not change resistors) (Figure 13-2).

12. Make sure the DMM DC volts function and auto-range are still selected.
13. Send the following command (this command outputs approximately 5mA for the Model 2306 and approximately 500mA for the Model 2306-PJ):

```
:CAL:PROT:STEP7
```

14. Note and record the DMM voltage reading, then calculate the current from the voltage reading and actual resistance value. Send that current value as the parameter for the following command:

```
:CAL:PROT:STEP8 <Calculated_Current>
```

Example: for the Model 2306, with a current of 4.5mA, the command would be:

```
:CAL:PROT:STEP8 4.5E-3
```

Example: for the Model 2306-PJ, with a current of 450mA, the command would be:

```
:CAL:PROT:STEP8 450E-3
```

Step 3: Perform Channel #2 (charger channel) calibration steps

1. Connect the OUTPUT #2 SOURCE, SENSE, and DVM IN terminals to the digital multimeter. Use the same general connections shown in Figure 13-1, but make your connections to the OUTPUT #2 terminals. (Connect SOURCE +, SENSE +, and DVM IN + to DMM INPUT HI; SOURCE -, SENSE -, and DVM IN - to DMM INPUT LO.)
2. Send the following command to output 14V:

```
:CAL:PROT:STEP9 14
```

3. Note and record the DMM reading, then send that reading as the parameter for the following command:

```
:CAL:PROT:STEP10 <DMM_Reading>
```

For example, if the DMM reading is 14.012V, the command would be:

```
:CAL:PROT:STEP10 14.012
```

4. Note and record a new DMM reading, then send that reading as the parameter for the following command:

```
:CAL:PROT:STEP11 <DMM_Reading>
```

5. Send the following command for DVM full-scale calibration:

```
:CAL:PROT:STEP12
```

6. Connect the Model 2306 OUTPUT #2 SOURCE terminals to the DMM volts input and characterized 4 Ω resistor. Use the connections shown in Figure 13-2, but make your connections to the OUTPUT #2 terminals instead. Be sure to observe proper polarity (SOURCE + to INPUT HI; SOURCE - to INPUT LO).

7. Make sure the digital multimeter DC volts function and auto-ranging are still selected.

8. Send the following command to output 1.9A for 5A full-scale calibration:

```
:CAL:PROT:STEP13 1.9
```

9. Note and record the DMM voltage reading, then calculate the current from that reading and 4 Ω resistor value. Send the following command using that calculated current as the parameter:

```
:CAL:PROT:STEP14 <Calculated_Current>
```

For example, with a current value of 1.894A, the command would appear as follows:

```
:CAL:PROT:STEP14 1.894
```

10. Note and record a new DMM voltage reading, then again calculate the current from the voltage and resistance. Send the calculated current value as the parameter for the following command:

```
:CAL:PROT:STEP15 <Calculated_Current>
```

11. Connect the characterized 3k Ω resistor in place of the 4 Ω resistor (Figure 13-3).
12. Make sure the DMM DC volts function and auto-range are still selected.
13. Send the following command to output approximately 5mA for 5mA full-scale calibration:

```
:CAL:PROT:STEP16
```

14. Note and record the DMM voltage reading, then calculate the current from the voltage reading and actual 3k Ω resistance value. Send that current value as the parameter for the following command:
15. :CAL:PROT:STEP17 <Calculated_Current>

Step 4: Program calibration date

Use following command to set the calibration date:

```
:CAL:PROT:DATE <yyyy>, <mm>, <dd>
```

Note that the year, month, and date must be separated by commas. The allowable range for the year is from 1998 to 2097, the month is from 1 to 12, and the date is from 1 to 31.

Step 5: Save calibration constants and lock out calibration

Calibration is now complete, so you can store the calibration constants in EEROM by sending the following command:

```
:CAL:PROT:SAVE
```

NOTE *Calibration will be temporary unless you send the SAVE command. Calibration data will not be saved if (1) calibration is locked, (2) invalid data exists, or (3) all steps were not completed in the proper sequence. In that case, the unit will revert to previous calibration constants.*

After saving constants, lock out calibration by sending:

```
:CAL:PROT:LOCK
```

Table 13-3
Remote calibration summary

Step ¹	Command	Description	Test connections ²
	:CAL:PROT:CODE 'KI002306'	Unlock calibration.	None
	:CAL:PROT:INIT	Initiate calibration.	None
0	:CAL:PROT:STEP0 14	Full-scale (14V) output.	Figure 13-1
1	:CAL:PROT:STEP1 <DMM_Reading>	Full-scale output cal.	Figure 13-1
2	:CAL:PROT:STEP2 <DMM_Reading>	Full-scale measure cal.	Figure 13-1
3	:CAL:PROT:STEP3	DVM full-scale cal.	Figure 13-1
4	:CAL:PROT:STEP4 1.9	Source full-scale current cal.	Figure 13-2
5	:CAL:PROT:STEP5 <Current>	5A current limit cal.	Figure 13-2
6	:CAL:PROT:STEP6 <Current>	5A measure cal.	Figure 13-2
7	:CAL:PROT:STEP7	Model 2306: Source 5mA full-scale current.	Figure 13-3
		Model 2306-PJ: Source 500mA full-scale current.	
8	:CAL:PROT:STEP8 <Current>	Model 2306: 5mA range measure cal.	Figure 13-3
		Model 2306-PJ: 500mA range measure cal.	
9	:CAL:PROT:STEP9 14	Full-scale (14V) output.	Figure 13-1
10	:CAL:PROT:STEP10 <DMM_Reading>	Full-scale output cal.	Figure 13-1
11	:CAL:PROT:STEP11 <DMM_Reading>	Full-scale measure cal.	Figure 13-1
12	:CAL:PROT:STEP12	DVM full-scale cal.	Figure 13-1
13	:CAL:PROT:STEP13 1.9	Source full-scale current cal.	Figure 13-2
14	:CAL:PROT:STEP14 <Current>	5A current limit cal.	Figure 13-2
15	:CAL:PROT:STEP15 <Current>	5A measure cal.	Figure 13-2
16	:CAL:PROT:STEP16	Source 5mA full-scale current.	Figure 13-3
17	:CAL:PROT:STEP17 <Current>	5mA range measure cal.	Figure 13-3
	:CAL:PROT:DATE <yyyy,mm,dd>	Program calibration date.	None
	:CAL:PROT:SAVE	Save calibration data.	None
	:CAL:PROT:LOCK	Lock out calibration.	None

¹ Step numbers correspond to :STEP commands. Steps 0 - 8 calibrate Channel #1 (battery channel). Steps 9 - 17 calibrate Channel #2 (charger channel).

² Connect to OUTPUT #1 terminals for Steps 0 -8. Connect to OUTPUT #2 terminals for Steps 9 - 17.

Changing the calibration code

The default calibration code may be changed from the front panel or via remote as discussed below.

Changing the code from the front panel

Follow the steps below to change the code from the front panel:

1. Press the MENU key, then choose CALIBRATE UNIT, and press ENTER. The instrument will display the last date calibrated:

```
CALIBRATE UNIT  
LAST ON 02/01/99
```

2. Press the ▲ key. The instrument will display the number of times it was calibrated:

```
CALIBRATE UNIT  
TIMES = 1
```

3. Press the ▲ key. The unit will then prompt you to run calibration:

```
CALIBRATE UNIT  
RUN
```

4. Press ENTER. The unit will then prompt for the calibration code:

```
CALIBRATE UNIT  
Cal Code KI002306
```

5. Using the edit keys, set the display to the current present calibration code then press ENTER. (Default: KI002306.) The unit will prompt you as to whether or not to change the code:

```
CALIBRATE UNIT  
Change Code NO
```

6. Select YES then press ENTER. The instrument will prompt you to change the code:

```
CALIBRATE UNIT  
New Code: KI002306
```

7. Use the edit keys to set the new code then press ENTER to accept the new code.
8. Press the MENU key to exit calibration and return to the main menu.

Changing the code by remote

To change the calibration code by remote, first send the present code, then send the new code. For example, the following command sequence changes the code from the 'KI002306' remote default to 'KI_CAL':

```
:CAL:PROT:CODE 'KI002306'
```

```
:CAL:PROT:CODE 'KI_CAL'
```

Use any combination of letters and numbers up to a maximum of eight characters.

Resetting the calibration code

If you forget the calibration code, you can unlock calibration and reset the code as outlined below. Refer to Section 14 for more detailed disassembly instructions.

WARNING Hazardous voltages are present inside the unit. Use caution to avoid electric shock, which could cause personal injury or death.

1. Remove the rear bezel.
2. Remove the six screws that secure the cover then remove the cover.
3. Locate J1013 on the front panel display board.
4. Momentarily short pins 3 and 7 of J1013 (refer to Figure 13-4). The instrument will briefly display the following message:

```
CAL CODE UNLOCK
```

```
DO FP CAL TO SEE
```

5. Go to the CALIBRATE UNIT selection in the main menu then press ENTER.
6. Go to RUN then press ENTER. The display will show:

```
CALIBRATE UNIT
```

```
New Code:
```

7. Either enter the desired code, then press ENTER, or simply press ENTER to keep the previously set calibration code.
8. Turn off the power then install the cover and rear bezel.

Figure 13-4
*Jumper connections
 to reset calibration
 code*

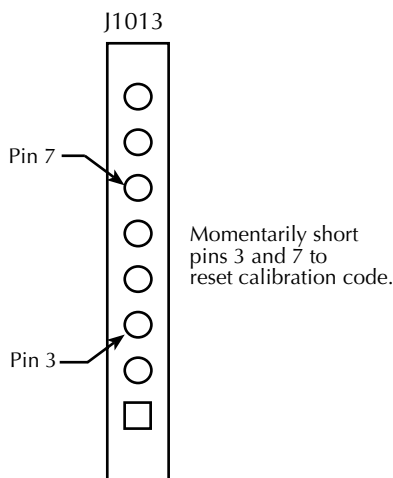

Viewing calibration date and count

Viewing date and count from the front panel

Follow the steps below to view the calibration date and count from the front panel:

1. Press the MENU key then choose CALIBRATE UNIT, and press ENTER. The instrument will display the last date calibrated:

```
CALIBRATE UNIT
LAST ON 02/01/99
```
2. Press the ▲ key. The instrument will display the number of times it was calibrated:

```
CALIBRATE UNIT
TIMES= 1
```
3. Press MENU to return to the menu structure.

Acquiring date and count by remote

Use the :DATE? and :COUNT? queries to determine the calibration date and count respectively. See *Miscellaneous commands* in *Appendix C* for more details.

14

Disassembly

Introduction

This section explains how to handle, clean, and disassemble the Model 2306 — drawings are located at the end of this section.

WARNING **The procedures in this section are intended only for qualified service personnel. Disconnect the line cord and all test leads and wires from the instrument before disassembling the unit.**

Handling and cleaning

To avoid contaminating PC board traces with body oil or other foreign matter, avoid touching the PC board traces while you are repairing the instrument. Some circuit board areas have high-impedance devices or sensitive circuitry where contamination could cause degraded performance.

Handling PC boards

Observe the following precautions when handling PC boards:

- Wear cotton gloves.
- Only handle PC boards by the edges and shields.
- Do not touch any board traces or components not associated with repair.
- Do not touch areas adjacent to electrical contacts.
- Use dry nitrogen gas to clean dust off PC boards.

Solder repairs

Observe the following precautions when soldering a circuit board:

- Use an OA-based (organic activated) flux, and take care not to spread the flux to other areas of the circuit board.
- Remove the flux from the work area when you have finished the repair by using pure water with clean, foam-tipped swabs or a clean, soft brush.
- Once you have removed the flux, swab only the repair area with methanol, then blow dry the board with dry nitrogen gas.
- After cleaning, allow the board to dry in a 50°C, low-humidity environment for several hours.

Static sensitive devices

CMOS devices operate at very high impedance levels. Therefore, any static that builds up on you or your clothing may be sufficient to destroy these devices if they are not handled properly. Use the following precautions to avoid damaging them:

CAUTION Many CMOS devices are installed in the Model 2306. Handle all semiconductor devices as being static sensitive.

- Transport and handle ICs only in containers specially designed to prevent static build-up. Typically, you will receive these parts in anti-static containers made of plastic or foam. Keep these devices in their original containers until ready for installation.
- Remove the devices from their protective containers only at a properly grounded work station. Ground yourself with a suitable wrist strap.
- Handle the devices only by the body; do not touch the pins.
- Ground any printed circuit board into which a semiconductor device is to be inserted to the bench or table.
- Use only anti-static type desoldering tools.
- Use only grounded-tip solder irons.
- Once the device is installed in the PC board, it is normally adequately protected, and you can handle the boards normally.

Assembly drawings

Use the assembly drawings located at the end of this section to assist you as you disassemble and reassemble the Model 2306. Refer to these drawings for information about the Keithley part numbers of most mechanical parts in the unit.

Assembly drawings include:

- Front panel assembly — 2306-040
- Chassis assembly — 2306-050
- Analog board to chassis assembly — 2306-051
- Final chassis assembly — 2306-052

Disassembly procedures

Case cover removal

Follow the steps below to remove the case cover to gain access to internal parts.

WARNING Before removing the case cover, disconnect the line cord and any test leads from the instrument.

1. Remove handle — The handle serves as an adjustable tilt-bail. Adjust its position by gently pulling it away from the sides of the instrument case and swinging it up or down. To remove the handle, swing the handle below the bottom surface of the case and back until the orientation arrows on the handles line up with the orientation arrows on the mounting ears. With the arrows lined up, pull the ends of the handle away from the case.
2. Remove mounting ears — Remove the screw that secures each mounting ear. Pull down and out on each mounting ear.

NOTE When reinstalling the mounting ears, make sure to mount the right ear to the right side of the chassis, and the left ear to the left side of the chassis. Each ear is marked “RIGHT” or “LEFT” on its inside surface.

3. Remove rear bezel — To remove the rear bezel, loosen the two screws that secure the rear bezel to the chassis, then pull the bezel away from the case.
4. Removing grounding screws — Remove the six grounding screws that secure the case to the chassis. They are located on the bottom of the case at the back.
5. Remove chassis — To remove the case, grasp the front of the instrument, and carefully slide the case off the chassis to the rear.

Analog board removal

Perform the following steps to remove the analog board. This procedure assumes that the case cover is already removed.

1. Unplug all cables connected to the analog board.
2. Remove the seven screws that secure the analog board to the chassis.
3. After all screws have been removed, carefully lift the analog board assembly free of the main chassis.

Digital board removal

Perform the following steps to remove the digital board. This procedure assumes that the analog board assembly has already been removed.

1. Remove the IEEE-488 connector fasteners that attach the connector to the rear panel.
2. Disconnect all cables and wires connected to the digital board.
3. Remove the front panel by prying out the four retaining clips while pulling the front panel away from the chassis.
4. Remove the three screws securing the digital board to the chassis (two outer screws of the heat sink (not all four) and one screw securing the tab on U113).
5. Remove the digital board by sliding it forward until it is free of the guide pins, then slide the board forward toward the front of the chassis until it can be pulled free.

During reassembly, replace the board, and start the IEEE-488 connector nuts. Tighten all the fasteners once they are all in place and the board is correctly aligned.

Front panel disassembly

Follow the steps below to disassemble the front panel. The procedure assumes that the front panel has already been removed from the chassis as described above.

1. Remove the four screws that secure the display board to the front panel.
2. Remove the display board from the front panel.

Removing mechanical components

The following procedures to remove the fan and line filter require that the case cover, front panel, and digital and analog circuit boards have been removed, as previously explained.

Fan removal

Perform the following steps to remove the fan:

1. Remove the four nuts that secure the fan to the rear panel.
2. Remove the fan from the chassis.
3. Pull out the fan connector from the digital board.

NOTE Digital board does not have to be removed to take out the fan.

Instrument reassembly

Reassemble the instrument by reversing the previous disassembly procedures. Make sure that all parts are properly seated and secured, and that all connections are properly made.

WARNING To ensure continued protection against electrical shock, verify that power line ground (green and yellow wire attached to the line filter module) is connected to the chassis. Also make certain that the two bottom case screws are properly installed to secure and ground the case cover to the chassis.

2306-040

ON

LTR	ECA NO.	REVISION	ENG	DATE
B	25273	2306-110B WAS 2306-011-11		

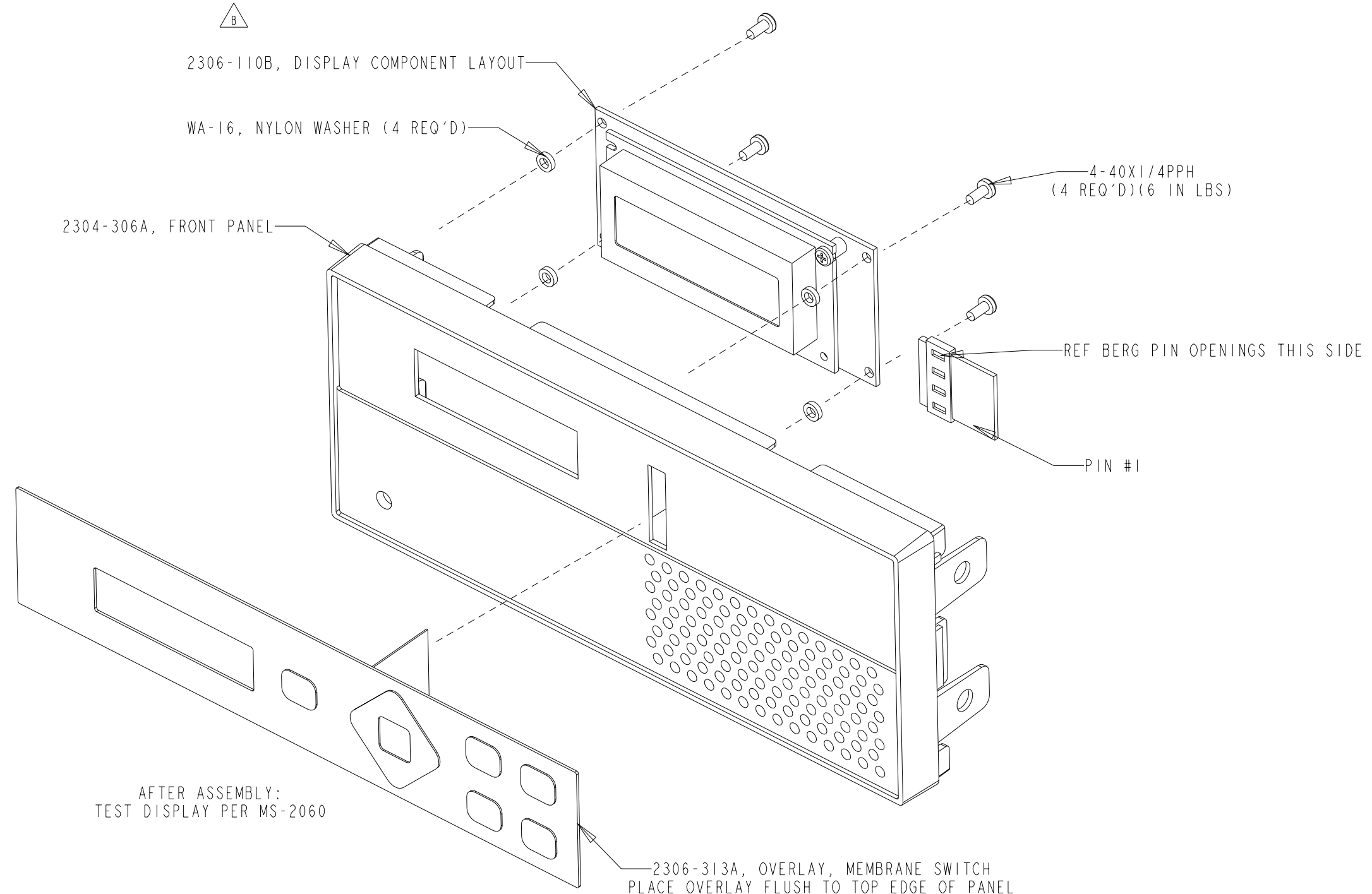

AFTER ASSEMBLY:
TEST DISPLAY PER MS-2060

2306	2306-050	Chassis Assembly	1
MODEL	NEXT ASSEMBLY	NEXT PROCESS STEP	QTY
USED ON			

PART NUMBER	QTY	DESCRIPTION
2304-306A	1	FRONT PANEL
2306-110B	1	DISPLAY, COMPONENT LAYOUT B
2306-313A	1	OVERLAY, MEMBRANE SWITCH
4-40X1/4PPH	4	PHIL PAN HEAD SCREW
WA-16	4	WASHER, NYLON

DO NOT SCALE THIS DRAWING

KEITHLEY Keithley Instruments Inc.
Cleveland, Ohio 44139

DIMENSIONAL TOLERANCES UNLESS OTHERWISE SPECIFIED	
XX = ±.015	ANG. = ±1°
XXX = ±.005	FRAC. = ±1/64
SURFACE MAX. \sqrt{R}	

DATE 18-Nov-98	SCALE - - - - -	TITLE
DRN.	MAT	ENG APPR. LS
MATERIAL		B
FINISH		
		NO. 2306-040

050-908Z

ON

DETAIL A

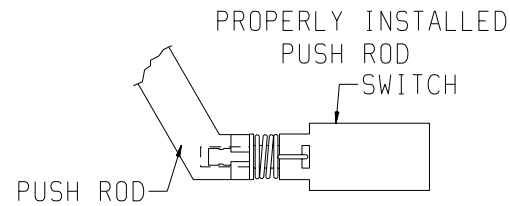

12
704-313A, PUSH ROD
SEE DETAIL A

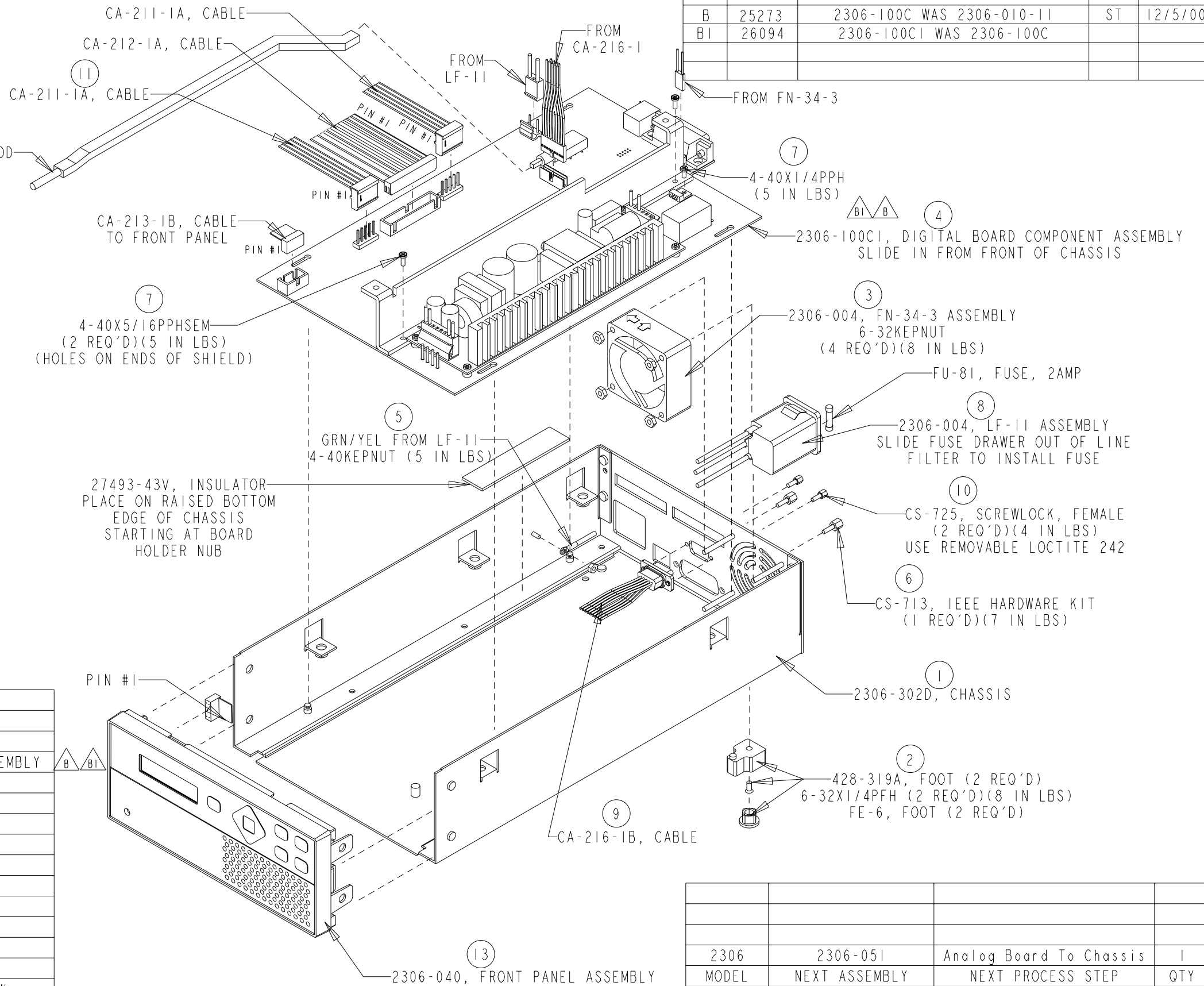

LTR	ECA NO.	REVISION	ENG	DATE
B	25273	2306-100C WAS 2306-010-11	ST	12/5/00
BI	26094	2306-100C1 WAS 2306-100C		

PART NUMBER	QTY	DESCRIPTION
2306-004	1	CRIMP ASSEMBLY
2306-040	1	FRONT PANEL ASSEMBLY
2306-100C1	1	DIGITAL BOARD COMPONENT ASSEMBLY
2306-302D	1	CHASSIS
428-319A	2	FOOT
704-313A	1	PUSH ROD
CS-713	1	HARDWARE KIT
FE-6	2	FOOT
4-40X1/4PPH	1	PHIL PAN HEAD SCREW
6-32X1/4PFH	2	PHIL FLAT HEAD SCREW
6-32KEPNUT	4	KEPNUT
FU-81	1	FUSE, 2AMP
4-40KEPNUT	1	KEPNUT
4-40X5/16PPHSEM	2	PHIL PAN HEAD SEMS SCREW
27493-43V	1	INSULATOR
CA-216-1B	1	CABLE
CA-211-1A	2	CABLE
CA-212-1A	1	CABLE
CA-213-1B	1	CABLE
CS-725	2	SCREWLOCK, FEMALE

MODEL	NEXT ASSEMBLY	NEXT PROCESS STEP	QTY
2306	2306-051	Analog Board To Chassis	1
USED ON			

DO NOT SCALE THIS DRAWING

DIMENSIONAL TOLERANCES UNLESS OTHERWISE SPECIFIED

XX = ±.015 ANG. = ±1'

XXX = ±.005 FRAC. = ±1/64

SURFACE MAX. \sqrt{R}

DATE 24-Nov-98 SCALE - - - -

DRN. MAT ENG APPR. L.S.

TITLE Chassis Assembly

NO. 2306-050

KEITHLEY Keithley Instruments Inc. Cleveland, Ohio 44139

190-908Z

ON

LTR	ECA NO.	REVISION	ENG	DATE
B	25273	2306-120F WAS 2306-012-11		

DETAIL A

REAR VIEW

4-40X5/16PPHSEM
(5 IN LBS)

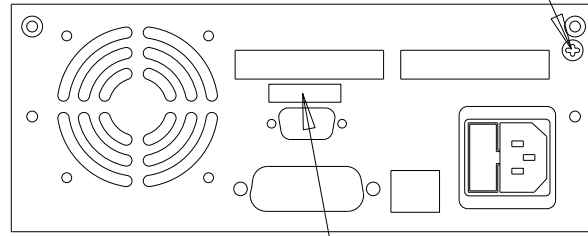

MC-285, SERIAL NUMBER

DETAIL B

REF BOTTOM SIDE
ANALOG BOARD

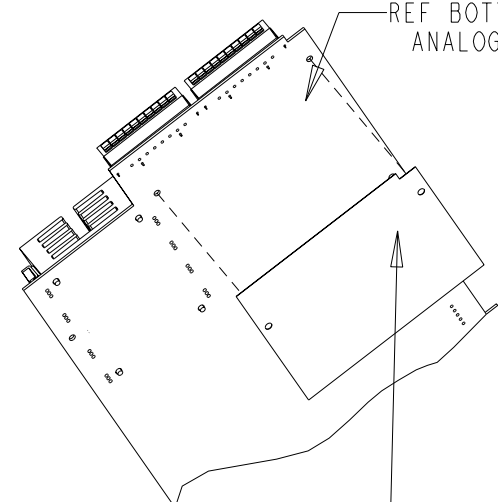

2306-311A, INSULATOR

2306-120F, ANALOG BOARD ASSEMBLY

DRESS EXCESS CABLE
TOWARDS TOP OF UNIT

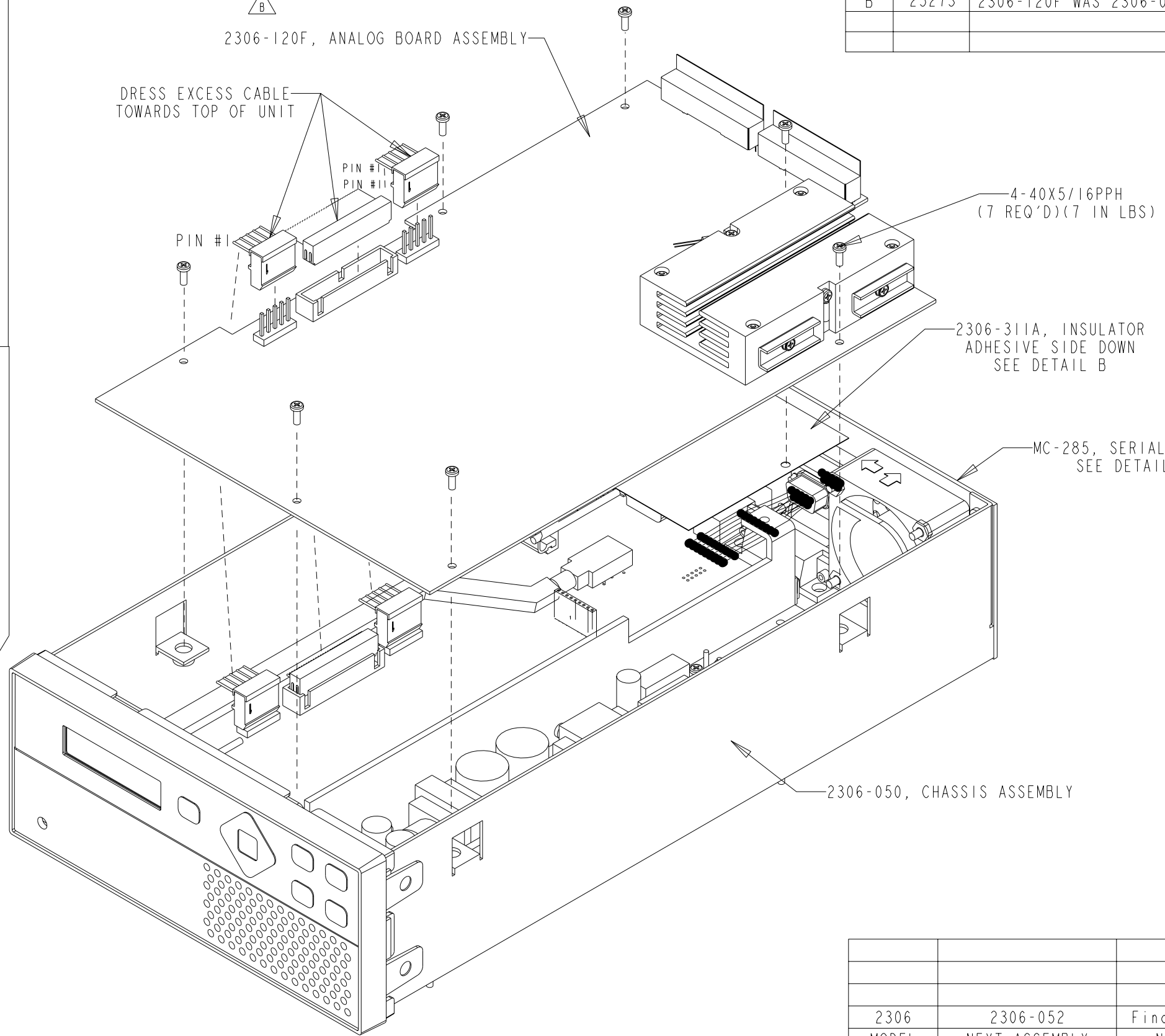

4-40X5/16PPH
(7 REQ'D)(7 IN LBS)

2306-311A, INSULATOR
ADHESIVE SIDE DOWN
SEE DETAIL B

MC-285, SERIAL NUMBER
SEE DETAIL A

2306-050, CHASSIS ASSEMBLY

PART NUMBER	QTY	DESCRIPTION
2306-050	1	CHASSIS ASSEMBLY
2306-120F	1	ANALOG BOARD ASSEMBLY
MC-285	1	SERIAL NUMBER
4-40X5-16PPH	7	PHIL PAN HEAD SCREW
2306-311A	1	INSULATOR
4-40X5-16PPHSEM	1	PHIL PAN HEAD SEMS SCREW

DO NOT SCALE THIS DRAWING

KEITHLEY Keithley Instruments Inc.
Cleveland, Ohio 44139

DIMENSIONAL TOLERANCES
UNLESS OTHERWISE SPECIFIED

XX = ±.015 ANG. = ±°

XXX = ±.005 FRAC. = ±1/64

SURFACE MAX. √

DATE 02-Dec-98

SCALE - - - - -

DRN. MAT ENG APPR. L. S.

MATERIAL

FINISH

TITLE

Analogue Board To Chassis

NO. 2306-051

2306	2306-052	Final Chassis Assembly	1
MODEL	NEXT ASSEMBLY	NEXT PROCESS STEP	QTY
USED ON			

2306-052

ON

LTR	ECA NO.	REVISION	ENG	DATE
A		Released		

STEP 1

STEP 2

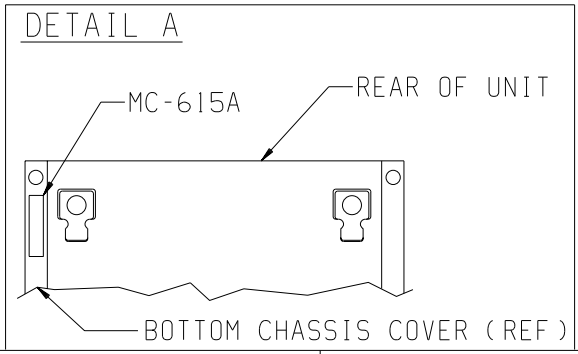
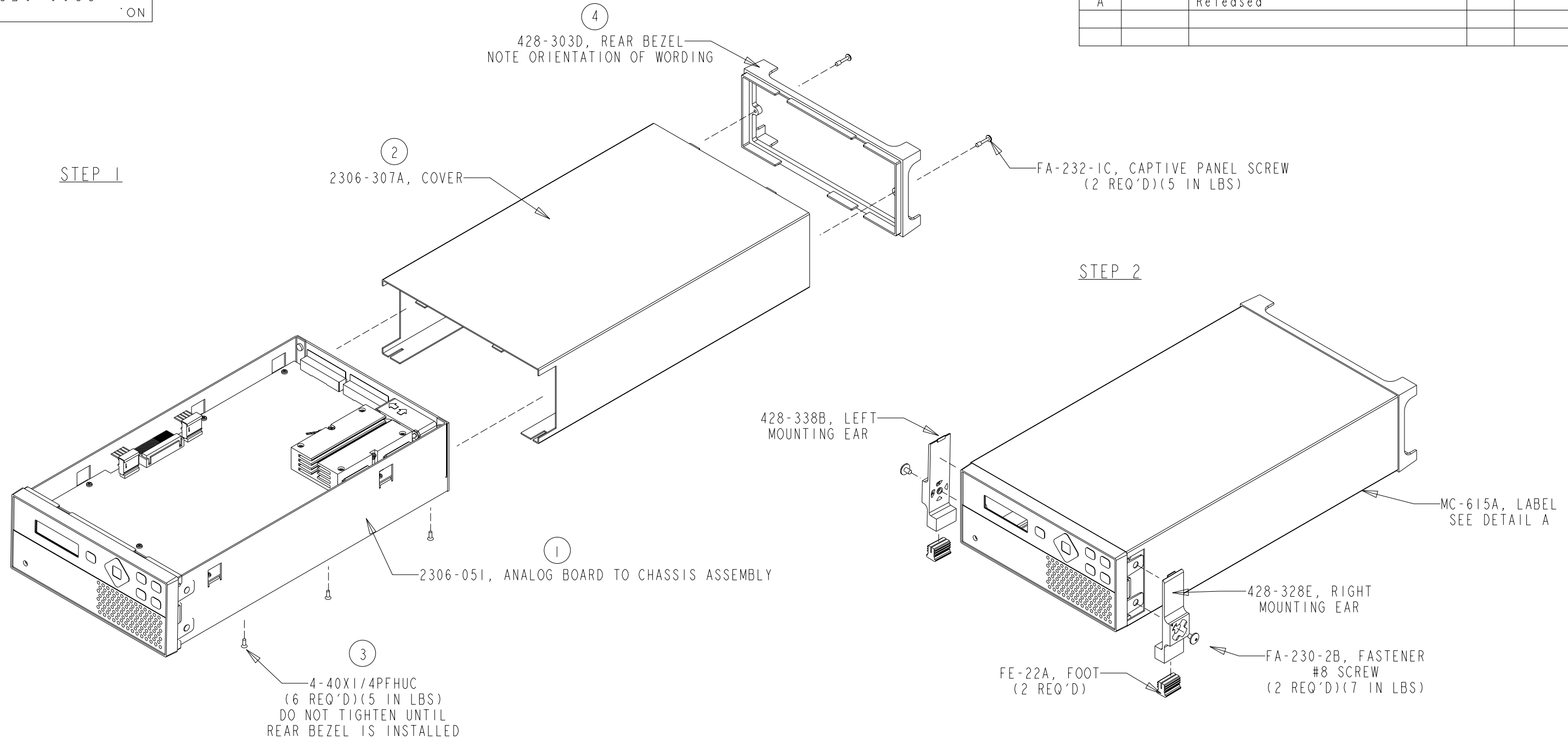

AGE UNIT PER MS-2063

PART NUMBER	QTY	DESCRIPTION
2306-051	1	ANALOG BOARD TO CHASSIS ASSEMBLY
2306-307A	1	COVER
428-303D	1	REAR BEZEL
428-328E	1	RIGHT MOUNTING EAR
428-338B	1	LEFT MOUNTING EAR
FA-230-2B	2	FASTENER
FA-232-1C	2	CAPTIVE PANEL SCREW
FE-22A	2	FOOT
MC-615A	1	LABEL, WARNING
4-40X1/4PFHUC	6	PHIL PAN HEAD UNDERCUT SCREW

2306	Tech	Tech	1
MODEL	NEXT ASSEMBLY	NEXT PROCESS STEP	QTY
USED ON			

DO NOT SCALE THIS DRAWING

DIMENSIONAL TOLERANCES UNLESS OTHERWISE SPECIFIED

XX = ±.015 ANG. = ±1°

XXX = ±.005 FRAC. = ±1/64

SURFACE MAX. $\sqrt{63}$

DATE 03-Dec-98 SCALE - - - - - TITLE Final Chassis Assembly

DRN. Mat ENG APPR.

MATERIAL FINISH

NO. 2306-052

KEITHLEY Keithley Instruments Inc. Cleveland, Ohio 44139

15

Replaceable Parts

Introduction

This section contains replacement parts information.

Ordering information

To place an order, or to obtain information concerning replacement parts, contact your Keithley representative or the factory. When ordering parts, be sure to include the following information:

- Instrument model number (for example, Model 2306)
- Instrument serial number
- Part description
- Component designation (if applicable)
- Keithley part number

Factory service

If the instrument is to be returned to Keithley Instruments for repair, perform the following:

- Call the Repair Department at 1-800-552-1115 for a RMA (Return Material Authorization) number.
- Complete the service form at the back of this manual, and include it with the instrument.
- Carefully pack the instrument in the original packing carton or equivalent.
- Write ATTENTION REPAIR DEPARTMENT and the RMA number on the shipping label.

Parts lists and component layouts

The parts lists for the Models 2306 are listed separately in tables on the following pages. For part numbers to the various mechanical parts and assemblies, use the assembly drawings provided at the end of *Section 14*. Component layout drawings are provided at the end of this section:

- Digital board – 2306-100
- Analog board – 2306-120
- Display board – 2306-110

Table 15-1
Digital board parts list

Circuit designation	Description	Keithley part no.
C101,C141,C201	CAP, 10UF, 20%, 25V, TANTALUM	C-440-10
C102,132,133,184,186,189,197-199,202,300	CAP, 0.1UF, 10%, 25V, CERAMIC	C-495-.1
C105,106,107,130,205,206,207,230	CAP, 100U, 20%, 20V, ALUM ELEC	C-583-100
C108,114,115,127,129,135,136,137,151,158	CAP, 0.1UF, 20%, 50V, CERAMIC	C-418-.1
C111,C119,C152,C211,C219,C252	CAP, 0.01UF, 10%, 50V, CERAMIC	C-491-.01
C112,C113,C212,C213	CAP, 10U, 20%, 35V, TANTALUM	C-551-10
C120,123,131,142,156,193,196,220,223	CAP, 0.1UF, 20%, 50V, CERAMIC	C-418-.1
C121,C122,C221,C222	CAPACITOR	C-570-470
C124,126,128,153,192,194,224,226,228	CAP, 22UF, 20%, 25V, TANTALUM	C-440-22
C125,C150,C225,C301	CAP, 22U, 20%, 25V, TANTALUM	C-535-22
C134,144,159,160,161,163,164,165,166,167	CAP, 0.1UF, 10%, 25V, CERAMIC	C-495-.1
C138,C139	CAP, .47U, 20%, 25V	C-520-47
C140	CAP, 2.2U, 10%, 50V, TANTALUM	C-563-2.2
C143,C311	CAP, 0.022UF, 10%, 50V, CERAMIC	C-491-.022
C145,309	CAP, 270PF, 5%, 100V, CERAMIC	C-465-270P
C146,C308	CAP, 1000PF, 10%, 50V, MONO CERAMIC	C-452-1000P
C147,C310	CAP, 100PF, 5%, 100V, CERAMIC	C-465-100P
C148	CAP, 0.01uF, 20%, 50V, CERAMIC	C-418-.01
C149	CAP, 0.47U, 20%, 25V	C-520-47
C154	CAP, 220UF, $\pm 20\%$, 50V, ALUM ELEC	C-507-220
C155	CAP, 0.01uF, 20%, 50V, CERAMIC	C-418-.01
C157	CAP, 100UF, 20%, 16V, TANTALUM	C-504-100
C162,C262	CAP, 47P, 5%, 100V, CERAMIC	C-465-47P
C168,169,173,175,176,177,178,179,180,181	CAP, 0.1UF, 20%, 50V, CERAMIC	C-418-.1
C170,C174	CAP, 0.01UF, 10%, 50V, CERAMIC	C-491-.01
C171,C172	CAP, 15P, 1%, 100V, CERAMIC	C-512-15P
C182,188,195,208,214,215,227,229,258,268	CAP, 0.1UF, 20%, 50V, CERAMIC	C-418-.1
C183	CAP, 0.1UF, 20%, 50V, CERAMIC	C-418-.1
C190,191,234,259,260,261,263,264,265	CAP, 0.1UF, 10%, 25V, CERAMIC	C-495-.1
C231,307	CAP, 0.1UF, 20%, 50V, CERAMIC	C-418-.1
C266,267,306	CAP, 0.1UF, 10%, 25V, CERAMIC	C-495-.1
C269,C302,C369	CAP, 0.1UF, 10%, 25V, CERAMIC	C-495-.1
C303,C304,C305,C100,C200	CAP, 47P, 5%, 100V, CERAMIC	C-465-47P
CR100,CR200	DIODE, DUAL HSM-2822T31	RF-95
CR101,CR201	RECTIFIER	RF-135

Table 15-1*Digital board parts list (cont.)*

Circuit designation	Description	Keithley part no.
CR102,CR202	ULTRA FAST BRIDGE RECTIFIER, EDF1BM	RF-123
CR104,CR106,CR204,CR206	DIODE, MBR5140T3	RF-110
CR107,CR207	RECTIFIER	RF-134
CR108	DIODE MBR5130LT3	RF-115
CR109,CR110,CR209,CR210	DIODE, SWITCHING, MMSD914T19	RF-112
CR111,CR112,CR211,CR212	DIODE, DUAL SWITCHING, BAV99L	RF-82
FH100,101,200,201	FUSE HOLDER, LITTLEFUSE 111501	FH-33
J1002	CONN, MOLEX, 3-PIN	CS-772-3
J1003	CONN, RIGHT ANGLE, 24 PIN	CS-501
J1004	SHIELDED RT. ANGLE PHONE JACK	CS-981
J1007,J1010	CONN MALE 5-PIN	CS-1060-5
J1008	CONN, HEADER, STRAIGHT SOLDER PIN	CS-368-10
J1009	CONN, HEADER, STRAIGHT SOLDER PIN	CS-368-34
L100,101,104,116,200,201	LINE FILTER	CH-85-10
L102	CHOKE	CH-56-1
L103	POWER INDUCTOR	CH-97-1
L105	CHOKE 1.2A	CH-94-1
L106,L107,L109,L110,L111,L112	FERRITE CHIP 600 OHM BLM32A07	CH-62
L108,L115	FERRITE BEAD	CH-91
PS100	POWER SUPPLY	PS-72A
Q100,101,200,201	TRANSISTOR SMT	TG-371
R101,R105,R201,R205	RES, 200, 5%, 250MW, METAL FILM	R-376-200
R112	RES, 10, 10%, 100MW, THICK FILM	R-418-10
R113,R114,R136,R159,R236	RES, 100, 1%, 100MW, THICK FILM	R-418-100
R115,149,166,168,100,118,179,181,184,200	RES, 10K, 1%, 100MW, THICK FILM	R-418-10K
R116,R178	RES, 10M, 1%, 125MW, THICK FILM	R-418-10M
R117,R180	RES, 1M, 1%, 100MW, THICK FILM	R-418-1M
R118,121,134,145,146,147,148,150,152,157	RES, 10K, 1%, 100MW, THICK FILM	R-418-10K
R119	RES, 66.5K, 1%, 100MW, THICK FILM	R-418-66.5K
R120	RES, 1M, 1%, 100MW, THICK FILM	R-418-1M
R122	RES, 24.9K, 1%, 100MW, THICK FILM	R-418-24.9K
R123	RES, 20K, 1%, 100MW, THICK FILM	R-418-20K
R124	RES, 2.55K, 1%, 1W, THICK FILM	R-418-2.55K
R125	RES, 11K, 1%, 100MW, THICK FILM	R-418-11K

Table 15-1*Digital board parts list (cont.)*

Circuit designation	Description	Keithley part no.
R126,128,130,132,137,138,139,140,141,142	RES, 475, 1%, 100MW, THICK FILM	R-418-475
R127,R129,R133,R227,R229,R233	RES, 475, 1%, 100MW, THICK FILM	R-418-475
R131,R231	RES, 1K, 1%, 125mW, METAL FILM	R-391-1K
R135,R235	RES, 1K, 5% 250MW, METAL FILM	R-376-1K
R143	RES, 1K, 1%, 100MW, THICK FILM	R-418-1K
R144,226,228,230,232,237,238,239,240,241	RES, 475, 1%, 100MW, THICK FILM	R-418-475
R151,R165,R174	RES, 4.75K, 1%, 100MW, THICK FILM	R-418-4.75K
R153	RES, 15k, 1%, 100MW, THICK FILM	R-418-15K
R154	RES, 332K, 1%, 100MW, THICK FILM	R-418-332K
R155	RES, 10M, 1%, 125MW, THICK FILM	R-418-10M
R156	RES, 499, 1%, 100MW, THICK FILM	R-418-499
R158,161,162,163,164,167,175,234	RES, 10K, 1%, 100MW, THICK FILM	R-418-10K
R160	RES, 866, 1%, 100MW, THICK FILM	R-418-866
R182,R183,R282,R283	RES, 68, 5%, 125MW, METAL FILM	R-375-68
R242	RES, 475, 1%, 100MW, THICK FILM	R-418-475
R284	RES, 10K, 1%, 100MW, THICK FILM	R-418-10K
RT100	THERMISTER, PD=7MW/DEG C, 1500V, 613.74K	RT-8
RV100	VARISTOR	VR-23
RV101,RV102,RV103	TRANSIENT VOLTAGE SUPPRESSOR	VR-19
S100	SWITCH, PUSHBUTTON (6 POLE)	SW-466
SO125	SOCKET PLCC-032-T-A	SO-143-32
T100,T200	TRANSFORMER	TR-338A
TP100-110,200-204	SURFACE MOUNT PCB TEST POINT	CS-1026
U100,U200	QUAD SCHMITT TRIG NAND GATE	IC-1291
U101,U201	DUAL D FLIP FLOP	IC-1292
U102,U202	IC, TRIPLE 3 IN NAND, 74F10	IC-659
U103,203	IC, DUAL POWER MOSFET DRIVER, ICL7667	IC-1118
U104,U204	VOLTAGE REGULATOR	IC-1132
U105,U205	VOLTAGE REGULATOR	IC-1133
U106,U206	-15V VOLTAGE REGULATOR	IC-1135
U107	DUAL 4 BIT BIN COUNTER	IC-1294
U108	IC, +5V RS-232 TRANSCEIVER, MAX202	IC-952
U109,U111	IC, VOLT COMPARATOR LM393D	IC-775
U110	IC, DUAL PICOAMP OP-AMP AD706JR	IC-910

Table 15-1*Digital board parts list (cont.)*

Circuit designation	Description	Keithley part no.
U112	ADJ VOLTAGE REG STEP DOWN	IC-1280
U113	IC, +5V, VOLTAGE REGULATOR, LM2940CT	IC-576
U114,U122,U214	SCMITT HEX INVERT	IC-1293
U115,116,117,119,215,216,217,219	HIGH SPEED OPTOCOUPLER HCPL-0631	IC-1153
U118,U120,U218,U220	TINYLOGIC CMOS INVERTER	IC-1282
U121	IC, GPIB ADAPTER, 9914A	LSI-123
U124	LARGE SCALE IC SMT	LSI-234-70
U125	PROGRAMMED ROM	2306-803A01
U126	IC, OCTAL INTERFACE BUS, 75160	IC-646
U127	IC, MOT MC68331CPV16	LSI-188
U128	IC, OCTAL INTER BUS TRANS, 75161	IC-647
U129,U133	IC, SERIAL EPROM, 24LC16B	LSI-153
U130	QUAD SPST ANALOG SWITCH	IC-1211
U131	RS-232 LINE DRIVER/RECEIVER	IC-1129
U132	INTEGRATED CIRCUIT	IC-1327
U134	IC, DARLINGTON ARRAY, ULN2003L	IC-969
U135,U136,U235,U236	INTEGRATED CIRCUIT	IC-1332
VR100	DIODE, ZENER, 6.2V, MMSZ6V2	DZ-97
Y100	CRYSTAL OSCILLATOR, 7.68M	CR-62-1
Y102	CRYSTAL, FSM327	CR-41

Table 15-2*Analog board parts list*

Circuit designation	Description	Keithley part no.
C400-403,405,406,411,413,418,420,421-424	CAP, 0.1UF, 20%, 50V, CERAMIC	C-418-.1
C404,C407,C604,C607	CAP, 2200P, 10%, 100V, CERAMIC	C-430-2200P
C408,C549,C608,C749	CAP, 1000pF, 20%, 50V, CERAMIC	C-418-1000P
C409,C609,C430,C783	CAP, 100PF, 5%, 100V, CERAMIC	C-465-100P
C410,415,543,544,610,615,446,531,586	CAP, 0.01UF, 10%, 50V, CERAMIC	C-491-.01
C412,414,416,447,449,566,612,614,616,477	CAP, 47P, 5%, 100V, CERAMIC	C-465-47P
C417	CAP, 150PF, 5%, 100V, CERAMIC	C-465-150P
C419,C523,C539,C619,C723,C739	CAP, 22UF, 20%, 25V, TANTALUM	C-440-22
C427,C627	CAP, 10U, 20%, 35V, ALUMINUM	C-562-10
C431,C432,C631,C632	CAP, 1500P, 20%, 700V	C-560-1500P
C434,C435,C634,C635	CAP, 1000P, 10%, 100V, CERAMIC	C-451-1000P
C436,C464,C636	CAP, 2.2U, 10%, 50V, TANTALUM	C-563-2.2
C438,439,440,441,557,559,638-641,759,782	CAP, 22U, 20%, 25V, TANTALUM	C-535-22
C442,448,487,529,537,567,583,588,600-603	CAP, 0.1UF, 20%, 50V, CERAMIC	C-418-.1
C450,C451,C650,C651	CAP, 0.47, 10%, 16V, CERAMIC	C-565-.47
C452,C652	CAP, 0.15UF, 20%, 50V, CERAMIC	C-418-.15
C453	CAP, 0.047U, 10%, 50V, CERAMIC	C-491-.047
C455,C458	CAP, 33PF, 5%, 100V, CERAMIC	C-465-33P
C457,459,462,465,468,469,471,473,474,476	CAP, 0.1UF, 10%, 25V, CERAMIC	C-495-.1
C460,C952	CAP, 22PF, 10%, 100V, CERAMIC	C-451-22P
C461,C683,C699	CAP, 0.1UF, 20%, 50V, CERAMIC	C-418-.1
C466,C647,C649,C660	CAP, 47P, 5%, 100V, CERAMIC	C-465-47P
C475,482,710,637,679,697,698,547,558	CAP, 0.1UF, 10%, 25V, CERAMIC	C-495-.1
C478,C494	CAP, 0.015UF, 10%, 50V, CERAMIC	C-491-.015
C480,C532	CAP, 1UF, 20%, 35V, TANTALUM	C-494-1
C481,C485,C536,C736	CAP, 2.2UF, 20%, 35V, TANTALUM	C-476-2.2
C484,488,492,493,540,569,570,581,582,584	CAP, 0.1UF, 10%, 25V, CERAMIC	C-495-.1
C486,489,490,499,500,501,502,521,524,527	CAP, 0.1UF, 10%, 25V, CERAMIC	C-495-.1
C491	CAP, 150PF, 5%, 100V, CERAMIC	C-465-150P
C495,C591	CAP, 220PF, 10%, 100V, CERAMIC	C-451-220P
C503,C574,C575	CAP, 3300P, 10%, 500V, CERAMIC	C-497-3300P
C504,C479,C590	CAP, 220PF, 10%, 100V, CERAMIC	C-451-220P
C507,508,510,512,644,645,740,593,643,682	CAP, 0.1UF, 10%, 25V, CERAMIC	C-495-.1
C513,C535,C628,C629,C713,C735	CAP, 0.01, 5%, 50V, NPO	C-514-.01
C514,C515,C517,C528,C714,C715,C717	CAP, 2.2U, 10%, 50V, TANTALUM	C-563-2.2
C519,C719	CAP, 220UF, $\pm 20\%$, 50V, ALUM ELEC	C-507-220

Table 15-2

Analog board parts list (cont.)

Circuit designation	Description	Keithley part no.
C525,C560,C563,C737,C760,C763	CAP, 0.1UF, 20%, 50V, CERAMIC	C-418-.1
C526,C726	CAP, 10U, 20%, 35V, TANTALUM	C-551-10
C530,533,545,546,555,556,755,756,766,767	CAP, 0.1UF, 10%, 25V, CERAMIC	C-495-.1
C538,C654,C656,C738,C595,C661	CAP, 10UF, 20%, 25V, TANTALUM	C-440-10
C541,741	CAP, 1000pF, 20%, 50V, CERAMIC	C-418-1000P
C542,C520,C534,C483,C552,C752,C633	CAP, 0.01UF, 10%, 50V, CERAMIC	C-491-.01
C550,C750	CAP, 2200P, 10%, 25V, CERAMIC	C-495-2200P
C561,C562,C564,C565,C761,C762,C764, C765	CAP, 680U, 20%, 50V, ALUM ELEC	C-578-680
C568,C630,C548,C579,C617	CAP, 100PF, 5%, 100V, CERAMIC	C-465-100P
C572,C463,C437,C706,C708,C712,C747, C758	CAP, 0.1UF, 10%, 25V, CERAMIC	C-495-.1
C573,C578,C701	CAP, 2200P, $\pm 10\%$, 500V, CERAMIC	C-497-2200P
C576,C577,C702,C720,C730,C734,C470, C472	CAP, 3300P, 10%, 500V, CERAMIC	C-497-3300P
C585,587,677,696,707,467,496,497,498,506	CAP, 0.1UF, 10%, 25V, CERAMIC	C-495-.1
C589	CAP, 2200P, 1%, 50V, CERAMIC	C-532-2200P
C596,C662	CAP, 0.01uF, 20%, 50V, CERAMIC	C-418-.01
C605,606,611,613,618,620-624,642,676,711	CAP, 0.1UF, 20%, 50V, CERAMIC	C-418-.1
C646,C658,C742,C743,C744,428,429,784, 785	CAP, 0.01UF, 10%, 50V, CERAMIC	C-491-.01
C653	CAP, 0.047U, 10%, 50V, CERAMIC	C-491-.047
C659,C675	CAP, 330P, 10%, 100V, CERAMIC	C-451-330P
C674	CAP, 2200P, $\pm 10\%$, 500V, CERAMIC	C-497-2200P
C678,687,594,705,625,626,571,516,518,522	CAP, 0.1UF, 20%, 50V, CERAMIC	C-418-.1
C681	CAP, 33PF, 10%, 50V, MONO CERAMIC	C-452-33P
C700,C786,C787,C688	CAP, 0.1UF, 10%, 25V, CERAMIC	C-495-.1
C703,C580	CAP, 390P, 10%, 100V, CERAMIC	C-451-390P
C716,718,725,505,511,648,655,657,722	CAP, 0.1UF, 20%, 50V, CERAMIC	C-418-.1
C768,769,770,771,772,773,774,775,778,779	CAP, 0.1UF, 10%, 25V, CERAMIC	C-495-.1
C780,781,425,426,433,443,444,445,454,456	CAP, 0.1UF, 10%, 25V, CERAMIC	C-495-.1
CR400,600	DIODE, DUAL HSM-2822T31	RF-95
CR401,CR601	DIODE, BRIDGE PE05	RF-48
CR402,CR602	DIODE, SILICON, 53A4	RF-47
CR408,412,603,607,608,612,407	DIODE, SWITCHING, MMSD914T19	RF-112
CR409,CR609	DIODE, BARRIER, MBR745	RF-65
CR413,613	SCHOTTKY DIODE	RF-125

Table 15-2

Analog board parts list (cont.)

Circuit designation	Description	Keithley part no.
CR414,415,614,615	DIODE, MBRS140T3	RF-110
J1007,J1010	CONN, MALE 5-PIN	CS-1060-5
J1009	CONN, HEADER, STRAIGHT SOLDER PIN	CS-368-34
J1014,J1015	CONNECTOR, MODULES	CS-834
L400,L401,L402,405-408,600-602,605-608	FERRITE CHIP 600 OHM BLM32A07	CH-62
L403,L404,L603,L604	FERRITE CHIP 600 OHM BLM32A07	CH-62
L409,L609,L413,L613	CHOKE SMT	CH-66-100
L410,L411,L610,L611	CHOKE	CH-98-1
L412,L612	CHOKE, 22UH	CH-66-22
Q400-403,600-603	TRANS, N-MOSFET, VN0605T	TG-243
Q404,Q604	TRANS, NPN, MMBT3904	TG-238
Q405,Q605	TRANS, PNP, MMBT3906L	TG-244
Q406,Q606	TRANSISTOR SMT	TG-371
Q407,Q408,Q607,Q608	HEXFET POWER MOSFET	TG-354
Q409-416,431-438,610-616,609,417,630	TRANS, N CHANNEL JFET, SNJ132199	TG-294
Q418,Q419,Q422,Q618,Q619,Q622	TRANS, N CHANNEL FET, 2N4392	TG-128-1
Q421,Q621	TRANS, CURRENT REGULATOR	TG-341
Q423,Q623	PNP SILICON TRANSISTOR	TG-310
Q424,Q429,Q620,Q624	N CHANNEL POWER MOSFET	TG-349
Q425,Q430,Q625,Q629	P CHANNEL POWER MOSFET	TG-348
Q426,626	NPN SILICON TRANSISTOR	TG-309
Q427,Q428,Q627,Q628	TRANSISTOR SMT	TG-376
R400,R600	RES NET	TF-245
R401,R601	RES, 6.04K, 1%, 125MW, THIN FILM	R-423-6.04K
R402,R404,R602,R604	RES, 2.21K, 1%, 100MW, THICK FILM	R-418-2.21K
R403,R603	RES, 1.28M, 0.1%, 1/8W, METAL FILM	R-176-1.28M
R405,R414,R587,R588,R751,R752,R443, R532	RES, 10K, 1%, 100MW, THICK FILM	R-418-10K
R406,R421,R606,R621	RES, 100, 1%, 100MW, THICK FILM	R-418-100
R407,463,466,468,661,662,685,686,687,697	RES, 1K, 1%, 100MW, THICK FILM	R-418-1K
R408,R608	RES, 5.11K, 1%, 100MW, THICK FILM	R-418-5.11K
R409,R609,R454,R456	RES, 470, 5%, 125MW, METAL FILM	R-375-470
R410,R412,R569,R610,R612,R660,R723	RES, 2K, 1%, 100MW, THICK FILM	R-418-2K
R411,R611,R504,R508	RES, 10, 10%, 100MW, THICK FILM	R-418-10
R413,R531,R613,R731	RES, 6.04K, 1%, 100MW, THICK FILM	R-418-6.04K

Table 15-2

Analog board parts list (cont.)

Circuit designation	Description	Keithley part no.
R415,R615	RES, 49.9K, 1%, 100MW, THICK FILM	R-418-49.9K
R416,R616,R721,R724	RES, 475, 1%, 100MW, THICK FILM	R-418-475
R417,556,593,651,758	RES, 10K, 1%, 100MW, THICK FILM	R-418-10K
R418,R618	RES, 34K, 1%, 100MW, THICK FILM	R-418-34K
R419,R619	RES, 82.5, 1%, 100MW, THICK FILM	R-418-82.5
R420,R620	RES, 4.75K, 1%, 100MW, THICK FILM	R-418-4.75K
R422,R447,R622,R674,R496,R647	RES, 100K, 1%, 100MW, THICK FILM	R-418-100K
R423,R623	RES, 3.01K, 1%, 125MW, METAL FILM	R-391-3.01K
R424,R425,R570,R624,R625,R650	RES, 10K, 5%, 250MW, METAL FILM	R-376-10K
R426,427,449,626,627	THICK FILM	TF-273-1
R429,R629	RES, 0.1, 1%, 3W	R-475-.1
R430,444,460,461,467,469,470,455,485,486	RES, 1K, 1%, 100MW, THICK FILM	R-418-1K
R431,R631	RES, 100, 0.1%, 1/2W, METAL FILM	R-169-100
R432,R550,R450	RES, 10K, 5%, 250MW, METAL FILM	R-376-10K
R435,R438,R635,R638	RES, 4.7K, 5%, 250MW, METAL FILM	R-376-4.7K
R436,R636	RES, 470K, 5%, 250MW, METAL FILM	R-376-470K
R437,R597,R637,R671	RES, 1M, 0.1%, 0.125MW, THIN FILM	R-456-1M
R439,R639,R665	THICK FILM	TF-273-4
R440,441,640,641	THICK FILM	TF-273-2
R442,R642	RES, 4.99K, 1%, 100MW, THICK FILM	R-418-4.99K
R445,R645	RES, 15K, 1%, 100MW, THICK FILM	R-418-15K
R446,646	RES, 909, 1%, 1W, THICK FILM	R-418-909
R448,R648	RES, 249K, 1%, 100MW, THICK FILM	R-418-249K
R451,R527	RES, 2.55K, 1%, 1W, THICK FILM	R-418-2.55K
R452,R453,R458	RES, 2.55K, 1%, 1W, THICK FILM	R-418-2.55K
R454,R579,R655,R744	RES, 6.04K, 1%, 100MW, THICK FILM	R-418-6.04K
R457,R515	RES, 2.74K, 1%, 0.1W, THICK FILM	R-418-2.74K
R464,R472,R632,R750	RES, 1K, 5%, 250MW, METAL FILM	R-376-1K
R465,R473,R522,R523	RES, 1M, 1%, 100MW, THICK FILM	R-418-1M
R474,R477,R511,R677,R696,R495,R652	RES, 100K, 1%, 100MW, THICK FILM	R-418-100K
R475,478,534,668,675,678,690,734,594,669	RES, 4.99K, 1%, 100MW, THICK FILM	R-418-4.99K
R476,R676,R595,R667	RES, 1M, 1%, 100MW, THICK FILM	R-418-1M
R481	RES, 9.76K, 1%, 100MW, THICK FILM	R-418-9.76K
R483,683,688,689,692,693,694,699,700	RES, 10K, 0.1%, 0.125W, THIN FILM	R-456-10K
R484,R516,R518	RES, 20K, 1%, 100MW, THICK FILM	R-418-20K
R488,R489,R492,R493,R494,R499,R500	RES, 10K, 0.1%, 0.125W, THIN FILM	R-456-10K

Table 15-2*Analog board parts list (cont.)*

Circuit designation	Description	Keithley part no.
R491	RES, 4.99K, 1%, 100MW, THIN FILM	R-438-4.99K
R497,R498,R644,R549,R749	RES, 1K, 1%, 100MW, THICK FILM	R-418-1K
R501,R510,R701,R710	RES, 100, 1%, 100MW, THICK FILM	R-418-100
R502,R596,R659,R664	RES, 10K, 1%, 100MW, THICK FILM	R-418-10K
R503,R509,R575,R576	RES, 499, 1%, 100MW, THICK FILM	R-418-499
R505,R506,R507,R586,R705,R706	RES, 0.2, 1%, 30W	R-463-.2
R514,R583	RES, 2.49K, 0.1%, 0.125MW, THIN FILM	R-456-2.49K
R517,R519,R551,R630	RES, 24.9K, 1%, 100MW, THICK FILM	R-418-24.9K
R526	RES, 80.6K, 1%, 100MW, THICK FILM	R-418-80.6K
R528,R535	RES, 9.76K, 1%, 100MW, THICK FILM	R-418-9.76K
R529,R729	RES, 3.32K, 1%, 100MW, THICK FILM	R-418-3.32K
R530,730	RES, 237, 1%, 100MW, THICK FILM	R-418-237
R533,R524,R617	RES, 10M, 1%, 125MW, THICK FILM	R-418-10M
R536,R653,R459,R513	RES, 0.0499, 1%, 100MW, THICK FILM	R-418-.0499
R537,R737	RES, 16.9K, 1%, 0.1W, THICK FILM	R-418-16.9K
R538,R738	RES, 59K, 1%, 100MW, THICK FILM	R-418-59K
R539,R739	RES, 40.2K, 1%, 100MW, THICK FILM	R-418-40.2K
R540,R740	RES, 40.2K, 1%, 100MW, THICK FILM	R-418-40.2K
R542,R742	RES, 6.19K, 1%, 100MW, THICK FILM	R-418-6.19K
R548,R748	RES, 0.015, 1.5W, 1%	R-468-.015
R552	RES, 274, 1%, 0.1W, THIN FILM	R-438-274
R553	RES, 2.49K, 1%, 0.1W, THIN FILM	R-438-2.49K
R554	RES, 24.9K, 1%, 100MW, THIN FILM	R-438-24.9K
R555	RES, 392, 1%, 100MW, THICK FILM	R-418-392
R557,R543,R580,R657,R743	RES, 2K, 1%, 100MW, THICK FILM	R-418-2K
R559,R564	RES, 475, 1%, 100MW, THICK FILM	R-418-475
R565,568,566,605,614,663,716-720,722	RES, 10K, 1%, 100MW, THICK FILM	R-418-10K
R571,R572	RES, 10K, 5%, 125MW, METAL FILM	R-375-10K
R573	RES, 200, 1%, 100MW, THICK FILM	R-418-200
R574	RES, 1.87K, 1%, 0.1W, THICK FILM	R-418-1.87K
R578,R656	RES, 4.02K, 1%, 100MW, THICK FILM	R-418-4.02K
R581,R658	RES, 8.06K, 1%, 0.1W, THICK FILM	R-418-8.06K
R582,R670	RES, 1.5K, 1%, 100MW, THICK FILM	R-418-1.5K
R584,R585	RES, 4.99K, 0.1%, 0.125W, THIN FILM	R-456-4.99K
R590,R756	RES, 11K, 1%, 100MW, THICK FILM	R-418-11K
R591,R755	RES, 73.2K, 1%, 100MW, THICK FILM	R-418-73.2K

Table 15-2

Analog board parts list (cont.)

Circuit designation	Description	Keithley part no.
R666,R592,R757	RES, 0.0499, 1%, 100MW, THICK FILM	R-418-.0499
R691	RES, 4.99K, 1%, 100MW, THIN FILM	R-438-4.99K
R698,R741,R487,R541,R607,R490,R649	RES, 1K, 1%, 100MW, THICK FILM	R-418-1K
R703,R709	RES, 499, 1%, 100MW, THICK FILM	R-418-499
R707	RES, 0.1, 1%, 30W	R-463-.1
R711,R520,R521	RES, 49.9K, 1%, 100MW, THICK FILM	R-418-49.9K
R725,726,563,482,525,561,567,643,712	RES, 10K, 1%, 100MW, THICK FILM	R-418-10K
R732,628,558,560,562,577,428,462,471,512	RES, 10K, 1%, 100MW, THICK FILM	R-418-10K
R733	RES, 10M, 1%, 125MW, THICK FILM	R-418-10M
R753,R754,R598,R672	RES, 10, 10%, 100MW, THICK FILM	R-418-10
RT400,RT401	THERMISTER, PD=7MW/DEG C, 1500V, 613.74K	RT-8
RV400,RV600	TRANSIENT VOLTAGE SUPPRESSOR	VR-19
RV401,RV601	VARIATOR	VR-21
TP401,TP402-TP405,TP601-TP604,TP400	SURFACE MOUNT PCB TEST POINT	CS-1026
TP600	CONNECTOR	CS-985
U400,U600	PROGRAM	2000-802A02
U401,U601	IC, QUAD D FLIP FLOP W/CLK, RESET 74HC175	IC-923
U402,U403,U602,U603	IC, QUAD 2 IN NOR, 74HCT02	IC-809
U404,U604	IC, NCHAN LAT DMOS QUADFET, SD5400CY	IC-893
U405,U605,U455,U466,U643,U654	INTEGRATED CIRCUIT, OPA177GS	IC-960
U406,424,436,439,464,606,623,636,639	PRECISION BIFET OPAMP	IC-1194
U407,U607	IC, DUAL BIPOLAR OP-AMP, LT1124CS8	IC-955
U409,U609	IC, OP-AMP, NE5534D	IC-802
U410,435,448,461,610,648,652,653,444,625	IC, VOLT. COMPARATOR, LM311M	IC-776
U411,U465	IC, OPAMP, LTC1150CS8	IC-1053
U412,U612	INTEGRATED CIRCUIT	IC-1333
U413,U457,U613	LOW POWER INSTRUMENT AMP	IC-1124
U414,415,421,423,438,614,615,638,425,449	IC, 20V OP-AMP, LT1097S8	IC-767
U416,U616	IC, 8-CHAN ANA MULTIPLEXER, DG408DY	IC-844
U417,U452,U462,U617	IC, 8 STAGE SHIFT/STORE, MC14094BD	IC-772
U418,U618	CMOS ANALOG SWITCH	IC-1210
U419,U619	HIGH PRECISION 10V REFERENCE	IC-1121
U420	INTEGRATED CIRCUIT	IC-1281

Table 15-2

Analog board parts list (cont.)

Circuit designation	Description	Keithley part no.
U422	INTEGRATED CIRCUIT	IC-1277
U426,U608	IC, CMOS ANAL SWITCH, DG444DY,	IC-866
U427,U428,U430	INTEGRATED CIRCUIT SMT	IC-1278
U429,U629	IC, INSTRUMENTATION AMPLIFIER, INA128UA	IC-1125
U431,U432,U443,U631,U632	IC, VOLT COMPARATOR, LM393D	IC-775
U433,U621	INTEGRATED CIRCUIT	IC-1331
U434,U624	IC, DUAL OP-AMP, LF353M	IC-842
U437,U442,U637,U642	IC, VOLTAGE REFERENCE, SOIC8	IC-1065
U440,U622	INTEGRATED CIRCUIT SMT	IC-1328
U441,U641	POWER OUTPUT STAGE AUTOMATIC BIAS SYSTEM	IC-1159
U445	IC, VOLTAGE REGULATOR, LM317T	IC-317
U446,U646	IC, POS NAND GATES/INVERT, 74HCT14	IC-656
U447,U647	12-BIT VOLTAGE OUTPUT DAC	IC-1130
U450,U650	SYNCHRONOUS DC/DC CONTROLLER	IC-1255
U451,U651	DUAL FET OPAMP	IC-1128
U453	IC, CMOS ANALOG SWITCH, DG211DY	IC-768
U454	IC, HI-SPEED BIFET OP-AMP, AD711JR	IC-894
U456,U626	IC, DUAL D-TYPE F/F, 74HC74	IC-773
U458	INTEGRATED CIRCUIT	IC-1302
U459	INTEGRATED CIRCUIT	IC-1299
U460	TINYLOGIC CMOS INVERTER	IC-1282
U463,U467	INTEGRATED CIRCUIT SMT	IC-1298
U611	DUAL ± 15 V ZERO DRIFT OPAMP	IC-1126
U620	DUAL 12-BIT MDAC	IC-1122
U645	IC, VOLTAGE REG, LM317M	IC-846
VR400,VR401,VR600,VR601	DIODE, ZENER, 6.2V, MMSZ6V2	DZ-97
VR402,VR602	DIODE, ZENER, 6.44V,1N4577AGED	DZ-58
VR403,VR603	DIODE, ZENER, 22V, BZX84C22	DZ-86
VR404,VR604	DIODE, ZENER	DZ-121
VR405,VR406,VR605,VR606,VR607	DIODE, ZENER, 12V, MMSZ12T1	DZ-112
VR407	DIODE, ZENER, 3V, CMPZ4619	DZ-118
Y400,Y600	OSCILLATOR, HIGH SPEED, CMOS, 12MHZ	CR-37

Table 15-3
 Display board parts list

Circuit designation	Description	Keithley part no.
C601,C602	CAP, 33PF, 10%, 100V, CERAMIC	C-451-33P
C603,C616	CAP, 0.1UF, 10%, 25V, CERAMIC	C-495-.1
C609	CAP, 0.1UF, 10%, 25V, CERAMIC	C-495-.1
C611	CAP, 10UF, 20%, 25V, TANTALUM	C-440-10
C613	CAP, 0.1UF, 20%, 50V, CERAMIC	C-418-.1
C614,C615	CAP, 390P, 10%, 100V, CERAMIC	C-451-390P
J1008	CONN, HEADER STRAIGHT SOLDER PIN	CS-368-10
J1013	CONNECTOR, RIGHT ANGLE	CS-362
J1014	CONN, BERG	CS-339
L601,L602,L603,L604	FERRITE CHIP 600 OHM, BLM32A07	CH-62
R601	RES, 10M, 5%, 125MW, METAL FILM	R-375-10M
R602-605,611,614,616,618,620,623	RES, 10K, 1%, 100MW, THICK FILM	R-418-10K
R606,608,610,613,615,617,619,621	RES, 15k, 1%, 100MW, THICK FILM	R-418-15K
R607	RES, 1.07K, 1%, 100MW, THIN FILM	R-438-1.07K
R612	RES, 4.75K, 1%, 100MW, THICK FILM	R-418-4.75K
R622	RES, 15k, 1%, 100MW, THICK FILM	R-418-15K
RV601,RV602	300W TRANSIENT VOLTAGE SUPPRESSOR ARRAY	VR-13
SO601	SOCKET	SO-143-44
U601	UNDERVOLTAGE SENSE CIRCUIT	IC-1067
U603, DISP BRD	PROGRAMMED ROM	2306-800B01
U604	INTEGRATED CIRCUIT SMT	IC-1305
Y601	CRYSTAL, 4MHZ	CR-36-4M
	VACUUM FLUORESCENT DISPLAY	DD-60

Table 15-4
Mechanical parts list

Description	Keithley part no.
BEZEL, REAR	428-303D
CHASSIS	2306-301
COVER	2306-307A
FAN	FN-34-3
FOOT	428-319A
FOOT, EXTRUDED	FE-22A
FOOT, RUBBER	FE-6
FUSE, EXP. 2A/5X20MM S-B	FU-81
HANDLE	428-329F
LINE CORD	CO-7
LINE FILTER	LF-11
MEMBRANE SWITCH	2306-313A
MOUNTING EAR, LEFT	428-338B
MOUNTING EAR, RIGHT	428-328E
POWER ROD	704-313A
PRINTED FRONT PANEL	V-2304-306A
REAR PANEL	2306-303

LTR.	ECA NO.	REVISION	ENG.	DATE
B		PRELIMINARY		
C	22397	RELEASED	MAH	1/25/99
D	25056	ADDED RT101	LM/ELS	11/29/00

PRIMARY SIDE COMPONENTS (SIDE -06)

MARK APPROPRIATE MODEL NUMBER.

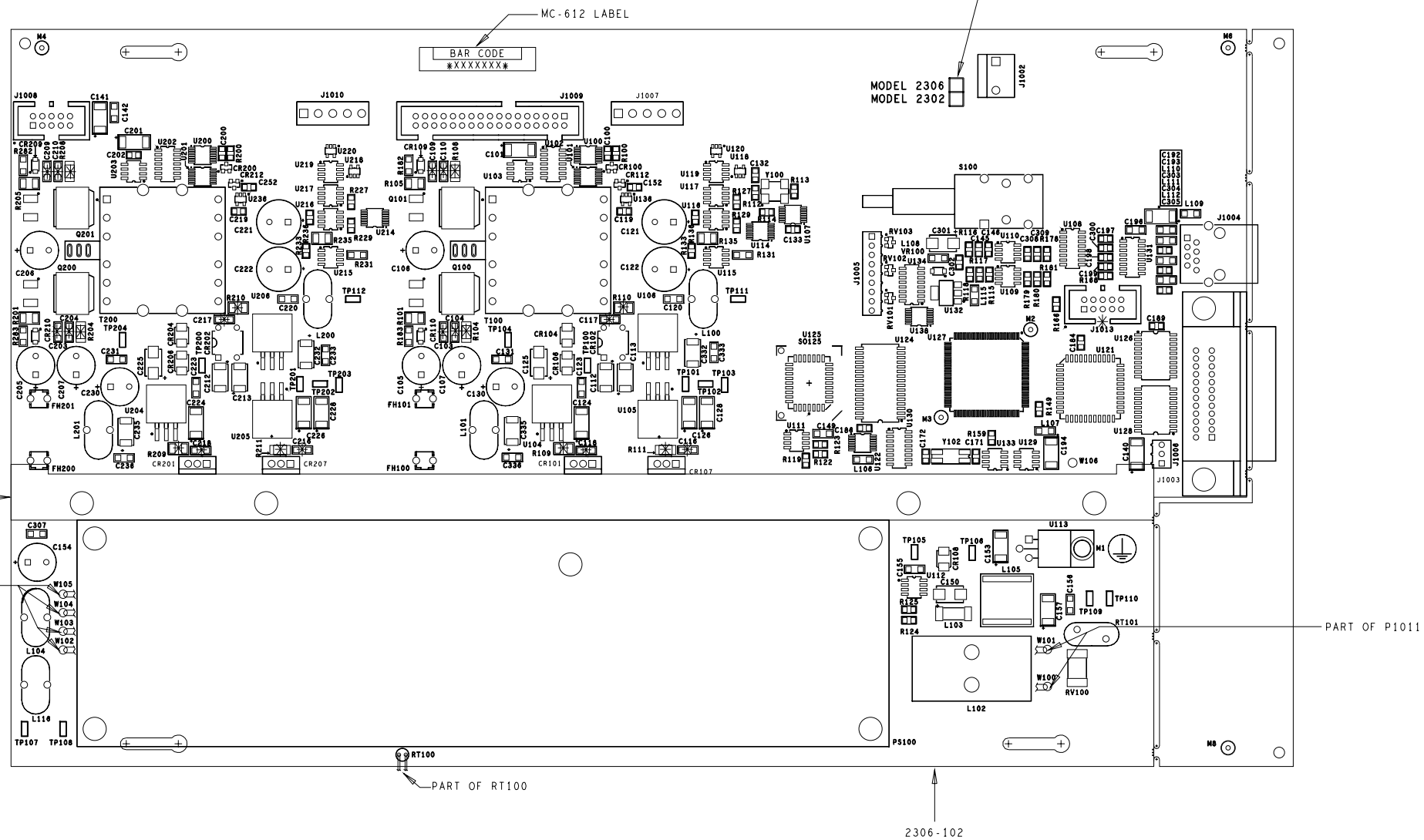

FOR MODEL 2306 ONLY

- * DO NOT POPULATE:
- PTH: J1013
- SMT: C103, C104, C109, C110, C116-C118, R104, R108-R111, C203, C204, C209, C210, C216-C218, R204, R208-R211.

NOTE: FOR COMPONENT INFORMATION, SEE PRODUCT STRUCTURE.

2302		
MODEL	NEXT ASSEMBLY	QTY.
USED ON		

 KEITHLEY INSTRUMENTS INC. CLEVELAND, OHIO 44139	DIM ARE IN IN. UNLESS OTHERWISE NOTED	DATE 7/14/98	SCALE 1:1	TITLE COMPONENT LAYOUT, DIGITAL BOARD
	DIM. TOL. UNLESS OTHERWISE SPECIFIED	DRN CAB	APPR. P.S.	
XX: .01 XXX: .005	ANG. : +1 FRAC. : +1/64	DO NOT SCALE THIS DRAWING	C	NO. 2306-100

LTR.	ECA NO.	REVISION	ENG.	DATE
B		PRELIMINARY		
C	22379	RELEASED	MAH	1/25/99
D	25056	ADDED RT101	LM/ELS	11/29/00

SECONDARY SIDE COMPONENTS (SIDE -01)

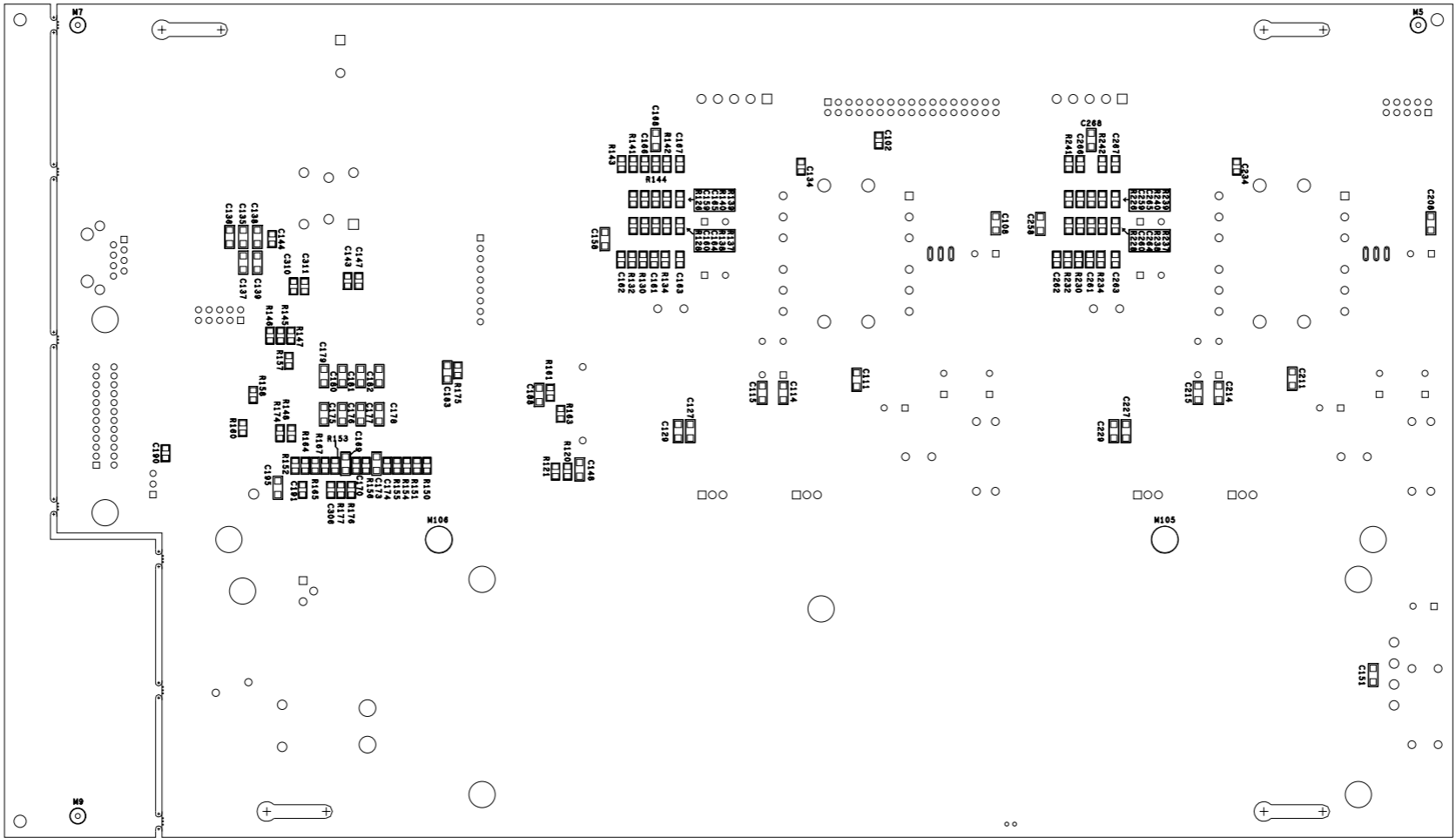

NOTE: FOR COMPONENT INFORMATION, SEE PRODUCT STRUCTURE.

MODEL	NEXT ASSEMBLY	QTY.
USED ON		

	DIM ARE IN IN. UNLESS OTHERWISE NOTED	DATE 7/14/98	SCALE 1:1	TITLE COMPONENT LAYOUT, DIGITAL BOARD
	DIM. TOL. UNLESS OTHERWISE SPECIFIED	DRN CAB	APPR. P.S.	
KEITHLEY INSTRUMENTS INC. CLEVELAND, OHIO 44139	XX±.01 ANG.±1 XXX±.005 FRAC.±1/64	DO NOT SCALE THIS DRAWING		C No. 2306-100

LTR.	ECA NO.	REVISION	ENG.	DATE
D	22699	ARTWORK CHG'D FROM C TO D.	MAH	3/5/99
E	22978	ARTWORK CHG'D FROM D TO E.	MS	5/6/99
E1	23467	ADDED Q439,R780 TO NO-POP LIST	ELS	11/17/99
F	23558	CHANGED ARTWORK FROM E TO F	LM/MLH	4/11/00
F1	24526	SEE PAGE TWO	JBN	5/22/00
F2	24670	DELETED R631 AS PART DIFFERENCE	LM/JBN	7/25/00

PRIMARY SIDE COMPONENTS (-06)
VIEWED FROM PRIMARY SIDE (-06)

MC - 612 LABEL

MARK APPROPRIATE MODEL NUMBER

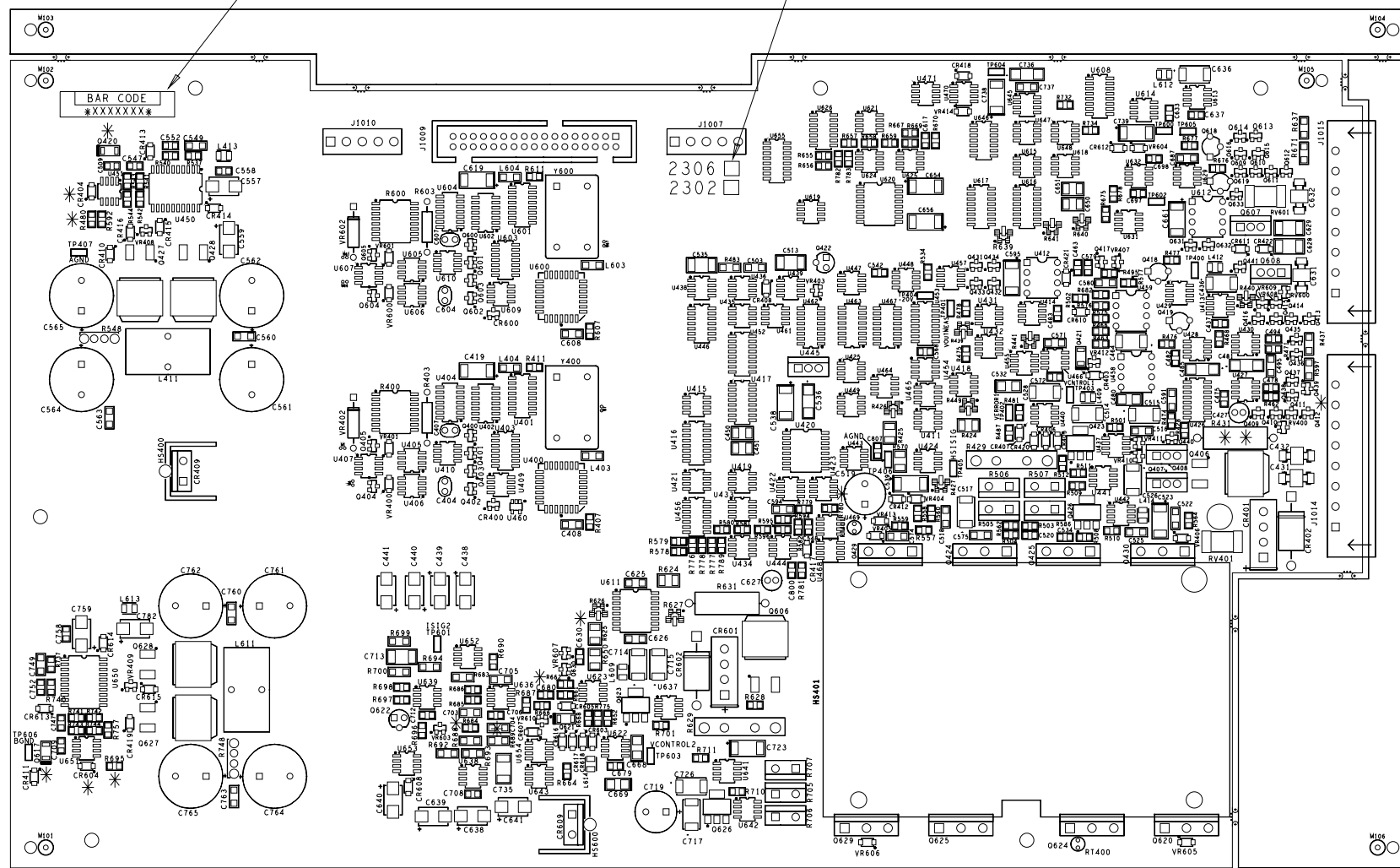

NOTE: FOR COMPONENT INFORMATION, SEE PRODUCT STRUCTURE.

* DO NOT POPULATE: SMT C630,C680,C704
CR404,CR604
Q420,O617,Q439
R480,R684,R695,R780

** PART DIFFERENCES:
(2306-PJ) R431

MODEL	NEXT ASSEMBLY	QTY.
USED ON		

<p>KEITHLEY INSTRUMENTS INC. CLEVELAND, OHIO 44139</p>	DIM ARE IN IN. UNLESS OTHERWISE NOTED	DATE 11/17/99	SCALE 1:1	TITLE COMPONENT LAYOUT, ANALOG BOARD
	DIM. TOL. UNLESS OTHERWISE SPECIFIED	DRN MAH	APPR. KC	
	XX:+.01 ANG.:+1 XXX:+.005 FRAC.:+1/64	DO NOT SCALE THIS DRAWING		

LTR.	ECA NO.	REVISION	ENG.	DATE
D	22699	CHG'D ARTWORK FROM C TO D.	MAH	3/5/99
E	22978	CHG'D ARTWORK FROM D TO E.	MS	5/6/99
E1	23467	ADDED R774,R487 TO NO-POP LIST	ELS	11/17/99
F	23558E	CHANGED ARTWORK FROM E TO F	LM/MLH	4/11/00
F1	24526	R798 & R799 NOW POPULATED R673 NOT POPULATED	JBN	5/22/00
F2	24670	DELETED R631 AS PART DIFFERENCE	LM/JBN	7/25/00

SECONDARY SIDE COMPONENTS (-01)
VIEWED FROM SECONDARY SIDE (-01)

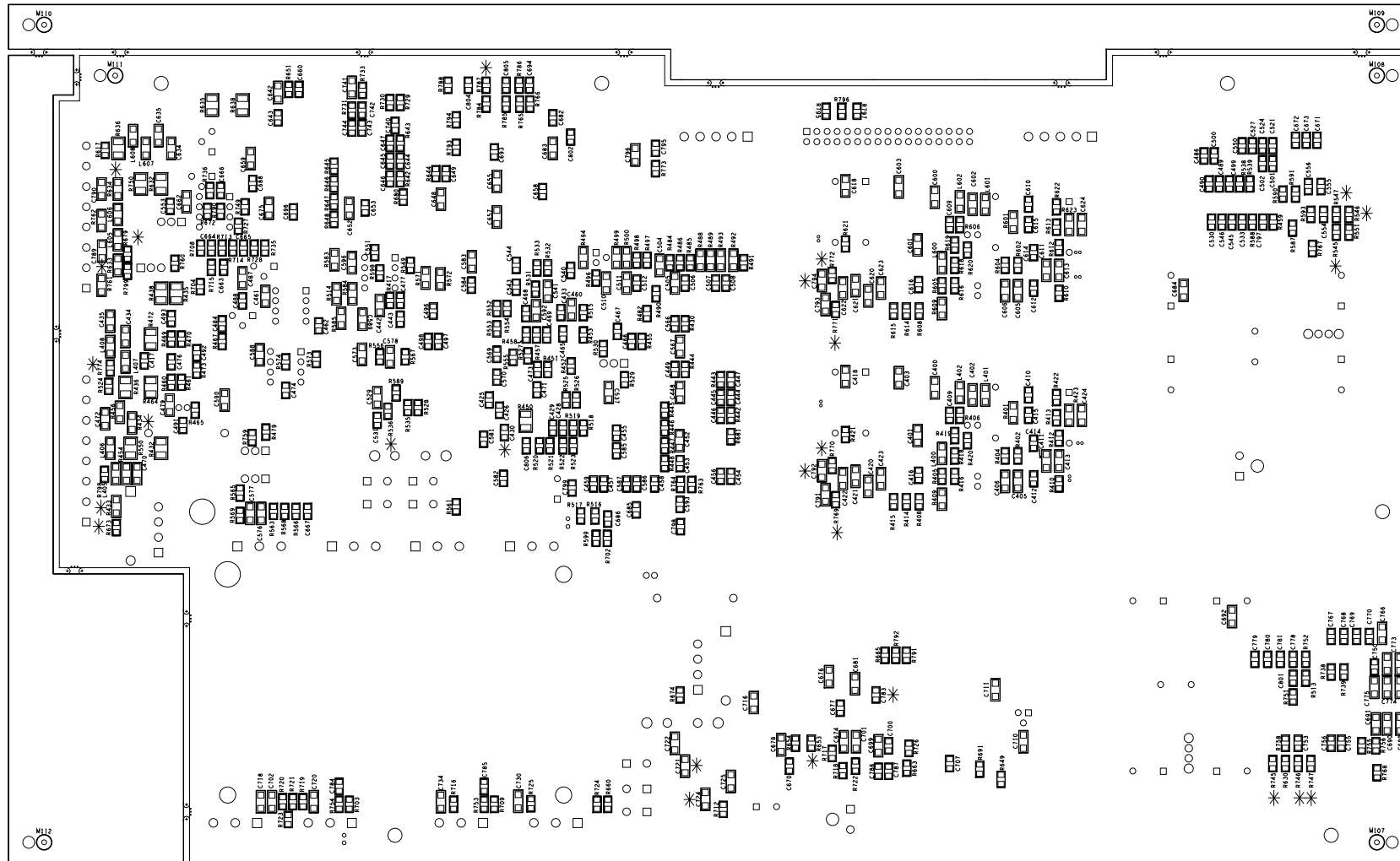

NOTE: FOR COMPONENT INFORMATION, SEE PRODUCT STRUCTURE.

* DO NOT POPULATE: SMT C430, C721, C724, C783, C792, C794,
R433, R434, R536, R545, R546, R547, R633, R634, R653, R673, R679,
R745, R746, R747, R769, R770, R771, R772, R774, R787

MODEL	NEXT ASSEMBLY	QTY.
USED ON		

 KEITHLEY INSTRUMENTS INC. CLEVELAND, OHIO 44139	DIM ARE IN IN. UNLESS OTHERWISE NOTED	DATE 11/17/99	SCALE 1:1	TITLE COMPONENT LAYOUT, ANALOG BOARD
	DIM. TOL. UNLESS OTHERWISE SPECIFIED	DRN MAH	APPR. KC	
	XX = .01 XXX = .005	ANG. = +1 FRAC. = +1/64	DO NOT SCALE THIS DRAWING	C NO. 2306-120

LTR.	ECA NO.	REVISION	ENG.	DATE
A	22770	RELEASED	MAH	3/12/99
B	22810	ADDED MODEL CHECK BOXES	MS	4/12/99
B1	24385	CNG'D FOR ARCHIVAL PURPOSE ONLY	JBN	4/24/00
B2	25053	REVISED A2306-111 REV B2	DHC	12/28/00

COMPONENTS FOR MODEL 2306

COMPONENTS FOR MODEL 2306-DISP

PRIMARY SIDE COMPONENTS (SIDE -02)

SECONDARY SIDE COMPONENTS (SIDE -01)

PRIMARY SIDE COMPONENTS (SIDE -02)

SECONDARY SIDE COMPONENTS (SIDE -01)

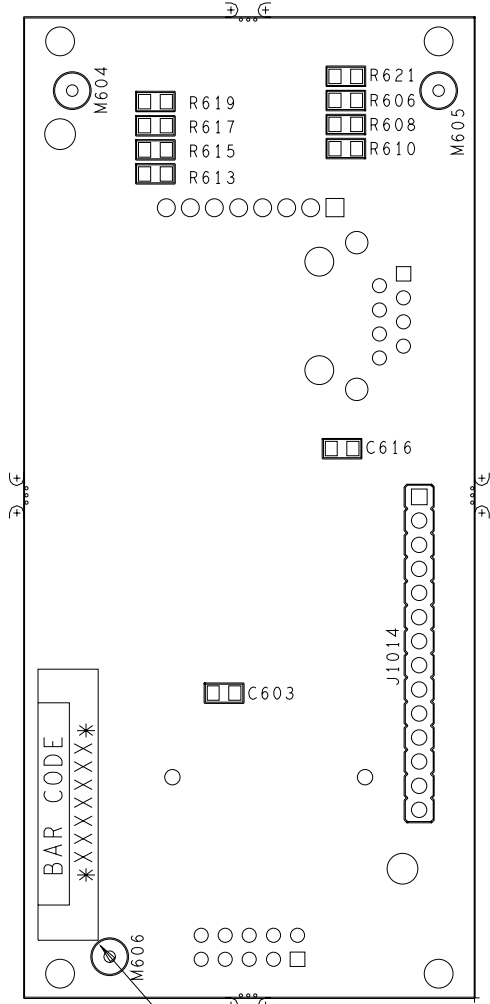
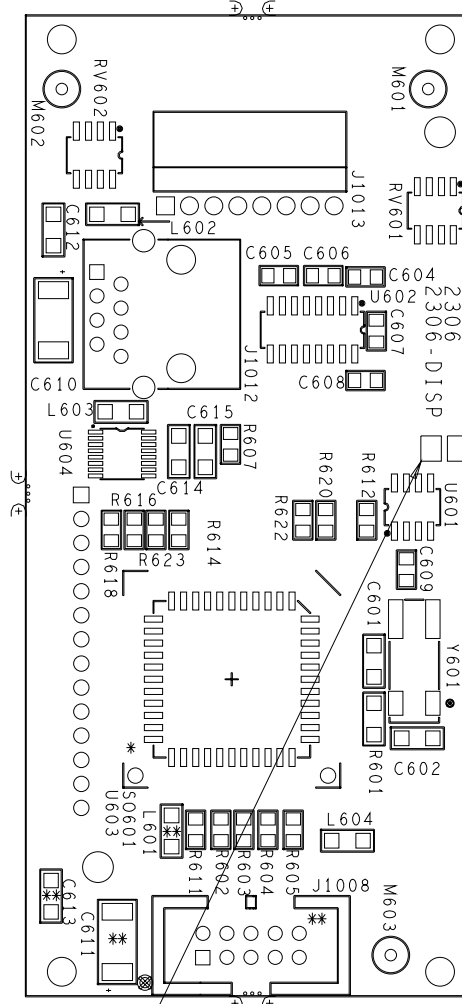
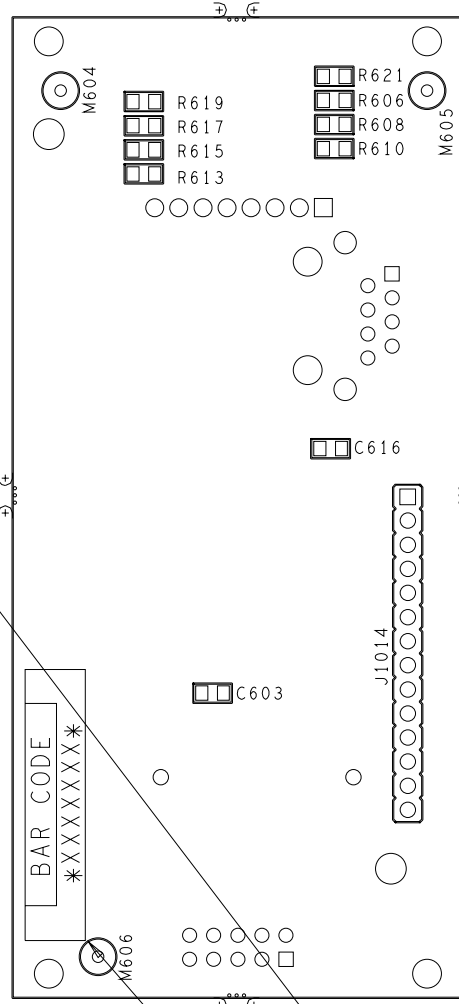
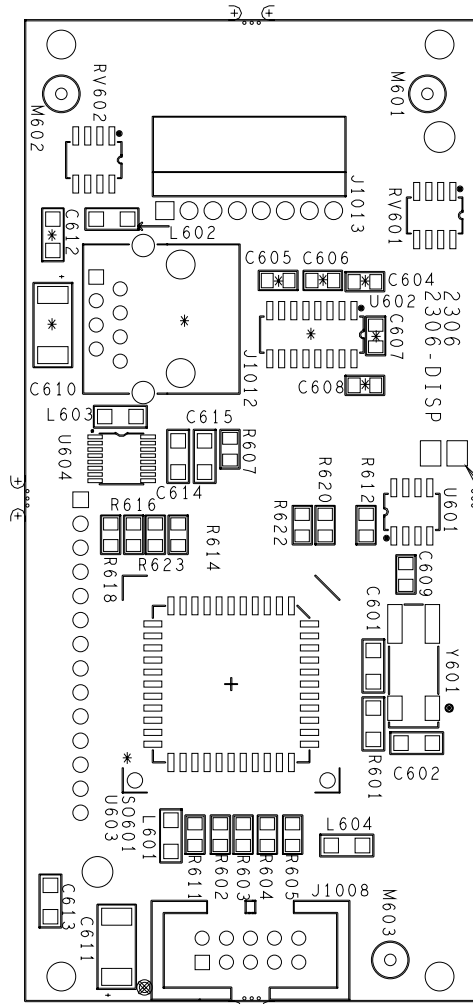

* DO NOT POPULATE THE FOLLOWING COMPONENTS:
 SMT: C604, C605, C606, C607, C608, C610, C612, U602, S0601
 PTH: J1012

** DO NOT POPULATE THE FOLLOWING COMPONENTS:
 SMT: C611, C613, L601, S0601
 PTH: J1008

MARK APPROPRIATE MODEL

NOTE: FOR COMPONENT INFORMATION, SEE PRODUCT STRUCTURE.

MODEL	NEXT ASSEMBLY	QTY.

USED ON

	DIM ARE IN IN. UNLESS OTHERWISE NOTED		DATE 8/27/98	SCALE 2:1	TITLE COMPONENT LAYOUT, DISPLAY/REMOTE BOARD
	DIM. TOL. UNLESS OTHERWISE SPECIFIED		DRN MAH	APPR. DCL PS	
KEITHLEY INSTRUMENTS INC. CLEVELAND, OHIO 44139	XX: .01 XXX: .005	ANG: .1 FRAC: .1/64	DO NOT SCALE THIS DRAWING	C	NO. 2306-110

A Specifications

2302 Battery Simulator

DC VOLTAGE OUTPUT (2 YEARS, 23°C ± 5°C)

OUTPUT VOLTAGE: 0 to +15VDC.
OUTPUT ACCURACY: ±(0.05% + 3mV).
PROGRAMMING RESOLUTION: 1mV.
READBACK ACCURACY¹: ±(0.05% + 3mV).
READBACK RESOLUTION: 1mV.
OUTPUT VOLTAGE SETTLING TIME: 5ms to within stated accuracy.
LOAD REGULATION: 0.01% + 2mV.
LINE REGULATION: 0.5mV.
STABILITY²: 0.01% + 0.5mV.
MEASUREMENT TIME CHOICES: 0.01 to 10 PLC⁷, in 0.01PLC steps.
AVERAGE READINGS: 1 to 10.
READING TIME^{1,8,9}: 31ms, typical.
TRANSIENT RESPONSE: **High Bandwidth** **Low Bandwidth**
 Transient Recovery Time¹³ <40µs³ or <60µs⁴ <80µs³ or <100µs⁴
 Transient Voltage Drop <75mV³ or <100mV⁴ <250mV³ or <400mV⁴
REMOTE SENSE: 1V max. drop in each lead. Add 2mV to the voltage load regulation specification for each 1V change in the negative output lead due to load current change. Remote sense required. Integrity of connection continually monitored. If compromised, output will turn off automatically once settable window (±0 to ±8 volts) around normal voltage exceeded.

VARIABLE OUTPUT IMPEDANCE

RANGE: 0 to 1.00Ω in 0.01Ω steps. Value can be changed with output on.

DC CURRENT (2 Years, 23°C ± 5°C)

OUTPUT CURRENT:
 0–4V: 5A max.
 >4V: $I_{MAX} = 60W / (V_{OUT} + 6)$ (not intended to be operated in parallel).
SOURCE COMPLIANCE ACCURACY: ±(0.16% + 5mA)⁵.
PROGRAMMED SOURCE COMPLIANCE RESOLUTION: 1.25mA.
READBACK ACCURACY¹: **5A Range:** ±(0.2% + 200µA).
 5mA Range: ±(0.2% + 1µA).
READBACK RESOLUTION: **5A Range:** 100µA.
 5mA Range: 0.1µA.
CURRENT SINK CAPACITY:
 0–5V: 3A max.
 5V–15V: Derate 0.2A per volt above 5V. Compliance setting controls sinking.
LOAD REGULATION: 0.01% + 1mA.
LINE REGULATION: 0.5mA.
STABILITY⁴: 0.01% + 50µA.
MEASUREMENT TIME CHOICES: 0.01 to 10 PLC⁷, in 0.01PLC steps.
AVERAGE READINGS: 1 to 10.
READING TIME^{1,8,9}: 31ms, typical.

PULSE CURRENT MEASUREMENT OPERATION

TRIGGER LEVEL: **5A Range:** 5mA to 5A, in 5mA steps.
 1A Range: 1mA to 1A, in 1mA steps.
 100mA Range: 0.1mA to 100mA, in 100µA steps.
TRIGGER DELAY: 0 to 100ms, in 10µs steps.
INTERNAL TRIGGER DELAY: 15µs.
HIGH/LOW/AVERAGE MODE:
 Measurement Aperture Settings: 33.3µs to 833ms, in 33.3µs steps.
 Average Readings: 1 to 100.

PULSE CURRENT MEASUREMENT ACCURACY¹¹ (2 Years, 23°C ± 5°C):

APERTURE	ACCURACY ±(% reading + offset + rms noise ¹⁰)
<100 µs	0.2% + 900 µA + 2 mA
100 µs – 200 µs	0.2% + 900 µA + 1.5mA
200 µs – 500 µs	0.2% + 900 µA + 1 mA
500 µs – <1 PLC	0.2% + 600 µA + 0.8mA
1 PLC ¹²	0.2% + 400 µA + 0 mA
>1 PLC	0.2% + 400 µA + 100 µA

BURST MODE CURRENT MEASUREMENT

MEASUREMENT APERTURE: 33.3µs.
CONVERSION RATE: 3650/second, typical.
INTERNAL TRIGGER DELAY: 15µs.
NUMBER OF SAMPLES: 1 to 5000.
TRANSFER SAMPLES ACROSS IEEE BUS IN BINARY MODE: 4800 bytes/s, typical.

LONG INTEGRATION MODE CURRENT MEASUREMENT

MEASUREMENT TIME⁶: 850ms (840ms) to 60 seconds in 1ms steps.

DIGITAL VOLTMETER INPUT (2 Years, 23°C ± 5°C)

INPUT VOLTAGE RANGE: –5 to +30VDC.
INPUT IMPEDANCE: 2MΩ typical.
MAXIMUM VOLTAGE (either input terminal) WITH RESPECT TO OUTPUT LOW: –5V, +30V.
READING ACCURACY¹: ±(0.05% + 3mV).
READING RESOLUTION: 1mV.
CONNECTOR: HI and LO input pair part of Output #1's terminal block.
MEASUREMENT TIME CHOICES: 0.01 to 10 PLC⁷, in 0.01PLC steps.
AVERAGE READINGS: 1 to 10.
READING TIME^{1,8,9}: 31ms, typical.

2302 Battery Simulator

GENERAL

ISOLATION (low-earth): 22VDC max.

PROGRAMMING: IEEE-488.2 (SCPI).

USER-DEFINABLE POWER-UP STATES: 5.

REAR PANEL CONNECTORS: 8-position quick disconnect terminal block for output (4), sense (2), and DVM (2).

TEMPERATURE COEFFICIENT (outside 23°C ±5°C): Derate accuracy specification by $(0.1 \times \text{specification})/^{\circ}\text{C}$.

OPERATING TEMPERATURE: 0° to 50°C (Derate to 70%). 0° to 35°C (Full power).

STORAGE TEMPERATURE: -20° to 70°C.

HUMIDITY: <80% @ 35°C non-condensing.

DISPLAY TYPE: 2-line × 16 character VFD.

REMOTE DISPLAY/KEYPAD OPTION: Disables standard front panel.

DIMENSIONS: 89mm high × 213mm wide × 41mm deep (3½ in × 8¾ in × 16¼ in).

NET WEIGHT: 3.2kg (7.1 lbs).

SHIPPING WEIGHT: 5.4kg (12 lbs).

INPUT POWER: 100–120VAC/220–240VAC, 50 or 60Hz (auto detected at power-up).

POWER CONSUMPTION: 150VA max.

WARRANTY: Two years parts and labor on materials and workmanship.

EMC: Conforms with European Union Directive directive 89/336/EEC, EN 55011, EN 50082-1, EN 61000-3-2 and 61000-3-3, FCC part 15 class B.

SAFETY: Conforms with European Union Directive 73/23/EEC, EN 61010-1.

AC LINE LEAKAGE CURRENT: 450µA @ 110VAC, typ.; 600µA @ 220V, typ.

RELAY CONTROL PORT: 4-channel, each capable of 100mA sink, 24V max. Total port sink capacity (all 4 combined) is 250mA max. Accepts DB-9 male plug.

ACCESSORIES SUPPLIED: User and service manual, output connectors mating terminal (part no. CS-846).

ACCESSORIES AVAILABLE:

Model 2304-DISP: Remote LCD Display/Keypad (4.6 in × 2.7 in × 1.5 in). Includes 2.7m (9 ft) cable and rack mount kit.

¹ PLC = 1.00.

² Following 15 minute warm-up, the change in output over 8 hours under ambient temperature, constant load, and line operating conditions.

³ Remote sense, at output terminals, 0.5A to 5A typical.

⁴ Remote sense, with 4.5m (15 ft) of 16 gauge (1.31mm²) wire and 1Ω resistance in each lead to simulate typical test environment, 1.5A load change (0.15A to 1.65A).

⁵ Minimum current in constant current mode is 6mA.

⁶ 60Hz (50Hz).

⁷ PLC = Power Line Cycle. 1PLC = 16.7ms for 60Hz operation, 20ms for 50Hz operation.

⁸ Display off.

⁹ Speed includes measurement and binary data transfer out of GPIB.

¹⁰ Typical values, peak-to-peak noise equals 6 times rms noise.

¹¹ Based on settled signal: 100µs pulse trigger delay.

¹² Also applies to other apertures that are integer multiples of 1PLC.

¹³ Recovery to within 20mV of previous level.

Specifications are subject to change without notice.

2302-PJ Battery Simulator

DC VOLTAGE OUTPUT (2 YEARS, 23°C ± 5°C)

OUTPUT VOLTAGE: 0 to +15VDC.

OUTPUT ACCURACY: ±(0.05% + 3mV).

PROGRAMMING RESOLUTION: 1mV.

REARBACK ACCURACY: ±(0.05% + 3mV).

REARBACK RESOLUTION: 1mV.

OUTPUT VOLTAGE SETTLING TIME: 5ms to within stated accuracy.

LOAD REGULATION: 0.01% + 2mV.

LINE REGULATION: 0.5mV.

STABILITY²: 0.01% + 0.5mV.

MEASUREMENT TIME CHOICES: 0.01 to 10 PLC⁷, in 0.01PLC steps.

AVERAGE READINGS: 1 to 10.

READING TIME^{1,8,9}: 31ms, typical.

TRANSIENT RESPONSE:	High Bandwidth	Low Bandwidth
Transient Recovery Time ¹³	<40µs ³ or <60µs ⁴	<80µs ³ or <100µs ⁴
Transient Voltage Drop	<75mV ³ or <100mV ⁴	<250mV ³ or <400mV ⁴

REMOTE SENSE 1V max. drop in each lead. Add 2mV to the voltage load regulation specification for each 1V change in the negative output lead due to load current change. Remote sense required. Integrity of connection continually monitored. If compromised, output will turn off automatically once settable window (±0 to ±8 volts) around normal voltage exceeded.

VARIABLE OUTPUT IMPEDANCE

RANGE: 0 to 1.00Ω in 0.01Ω steps. Value can be changed with output on.

DC CURRENT (2 Years, 23°C ± 5°C)

CONTINUOUS AVERAGE OUTPUT CURRENT:

0–4V: 5A max.

>4V: $I_{MAX} = 60W / (V_{SET} + 6)$ (Not intended to be operated in parallel).

Peak currents can be a maximum of 5A provided the average current is within the above limits.

CONTINUOUS AVERAGE SINK CURRENT:

0–5V: 3A max.

5–15V: Derate 0.2A per volt above 5V. Compliance setting controls sinking.

SOURCE COMPLIANCE ACCURACY: ±(0.16% + 5mA)⁵.

PROGRAMMED SOURCE COMPLIANCE RESOLUTION: 1.25mA.

REARBACK ACCURACY: 5A Range: ±(0.2% + 200µA).
500mA Range: ±(0.2% + 20µA).

REARBACK RESOLUTION: 5A Range: 100µA.
500mA Range: 10µA.

LOAD REGULATION: 0.01% + 1mA.

LINE REGULATION: 0.5mA.

STABILITY⁴: 0.01% + 50µA.

MEASUREMENT TIME CHOICES: 0.01 to 10 PLC⁷, in 0.01PLC steps.

AVERAGE READINGS: 1 to 10.

READING TIME^{1,8,9}: 31ms, typical.

PULSE CURRENT MEASUREMENT OPERATION

TRIGGER LEVEL:

5A Current Range

5A Range: 5mA to 5A, in 5mA steps.

1A Range: 1mA to 1A, in 1mA steps.

100mA Range: 0.1mA to 100mA, in 100µA steps.

500mA Current Range

500mA Range: 0.5mA to 500mA, in 0.5mA steps.

100mA Range: 0.1mA to 100mA, in 100µA steps.

10mA Range: 100µA to 10mA, in 100µA steps.

TRIGGER DELAY: 0 to 100ms, in 10µs steps.

INTERNAL TRIGGER DELAY: 15µs.

HIGH/LOW/AVERAGE MODE:

Measurement Aperture Settings: 33.3µs to 833ms, in 33.3µs steps.

Average Readings: 1 to 100.

PULSE CURRENT MEASUREMENT ACCURACY¹¹ (2 Years, 23°C ± 5°C):

APERTURE	ACCURACY ±(% reading + offset + rms noise ¹⁰)	
	5A RANGE	500mA RANGE
<100 µs	0.2% + 900 µA + 2 mA	0.2% + 90 µA + 2 mA
100 µs – 200 µs	0.2% + 900 µA + 1.5 mA	0.2% + 90 µA + 1.5 mA
200 µs – 500 µs	0.2% + 900 µA + 1 mA	0.2% + 90 µA + 1 mA
500 µs – <1 PLC	0.2% + 600 µA + 0.8 mA	0.2% + 60 µA + 0.8 mA
1 PLC ¹²	0.2% + 400 µA + 0 mA	0.2% + 40 µA + 0 mA
>1 PLC	0.2% + 400 µA + 100 µA	0.2% + 40 µA + 100 µA

BURST MODE CURRENT MEASUREMENT

MEASUREMENT APERTURE: 33.3µs.

CONVERSION RATE: 3650/second, typical.

INTERNAL TRIGGER DELAY: 15µs.

NUMBER OF SAMPLES: 1 to 5000.

TRANSFER SAMPLES ACROSS IEEE BUS IN BINARY MODE: 4800 bytes/s, typical.

LONG INTEGRATION MODE CURRENT MEASUREMENT

Available on both 5A and 500mA current ranges.

MEASUREMENT TIME⁶: 850ms (840ms) to 60 seconds in 1ms steps.

DIGITAL VOLTMETER INPUT (2 Years, 23°C ± 5°C)

INPUT VOLTAGE RANGE: –5 to +30VDC.

INPUT IMPEDANCE: 2MΩ typical.

MAXIMUM VOLTAGE (either input terminal) WITH RESPECT TO OUTPUT LOW: –5V, +30V.

READING ACCURACY: ±(0.05% + 3mV).

READING RESOLUTION: 1mV.

CONNECTOR: HI and LO input pair part of Output #1's terminal block.

MEASUREMENT TIME CHOICES: 0.01 to 10 PLC⁷, in 0.01PLC steps.

AVERAGE READINGS: 1 to 10.

READING TIME^{1,8,9}: 31ms, typical.

2302-PJ Battery Simulator

GENERAL

ISOLATION (low-earth): 22VDC max. Do not exceed 60VDC between any two terminals of either connector.

PROGRAMMING: IEEE-488.2 (SCPI).

USER-DEFINABLE POWER-UP STATES: 4.

REAR PANEL CONNECTORS: 8-position quick disconnect terminal block for output (4), sense (2), and DVM (2).

TEMPERATURE COEFFICIENT (outside 23°C ±5°C): Derate accuracy specification by $(0.1 \times \text{specification})/^{\circ}\text{C}$.

OPERATING TEMPERATURE: 0° to 50°C (Derate to 70%). 0° to 35°C (Full power).

STORAGE TEMPERATURE: -20° to 70°C.

HUMIDITY: <80% @ 35°C non-condensing.

DISPLAY TYPE: 2-line × 16 character VFD.

REMOTE DISPLAY/KEYPAD OPTION: Disables standard front panel.

DIMENSIONS: 89mm high × 213mm wide × 41mm deep (3½ in × 8½ in × 16⅜ in).

NET WEIGHT: 3.2kg (7.1 lbs).

SHIPPING WEIGHT: 5.4kg (12 lbs).

INPUT POWER: 100–120VAC/220–240VAC, 50 or 60Hz (auto detected at power-up).

POWER CONSUMPTION: 150VA max.

WARRANTY: Two years parts and labor on materials and workmanship.

EMC: Conforms with European Union Directive directive 89/336/EEC.

SAFETY: Conforms with European Union Directive 73/23/EEC.

AC LINE LEAKAGE CURRENT: 450µA @ 110VAC, typ.; 600µA @ 220V, typ.

RELAY CONTROL PORT: 4-channel, each capable of 100mA sink, 24V max. Total port sink capacity (all 4 combined) is 250mA max. Accepts DB-9 male plug.

ACCESSORIES SUPPLIED: User and service manual, output connectors mating terminal (part no. CS-846).

ACCESSORIES AVAILABLE:

Model 2304-DISP: Remote LCD Display/Keypad (4.6 in × 2.7 in × 1.5 in). Includes 2.7m (9 ft) cable and rack mount kit.

¹ PLC = 1.00.

² Following 15 minute warm-up, the change in output over 8 hours under ambient temperature, constant load, and line operating conditions.

³ Remote sense, at output terminals, 0.5A to 5A typical.

⁴ Remote sense, with 4.5m (15 ft) of 16 gauge (1.31mm²) wire and 1Ω resistance in each lead to simulate typical test environment, 1.5A load change (0.15A to 1.65A).

⁵ Minimum current in constant current mode is 6mA.

⁶ 60Hz (50Hz).

⁷ PLC = Power Line Cycle. 1PLC = 16.7ms for 60Hz operation, 20ms for 50Hz operation.

⁸ Display off.

⁹ Speed includes measurement and binary data transfer out of GPIB.

¹⁰ Typical values, peak-to-peak noise equals 6 times rms noise.

¹¹ Based on settled signal: 100µs pulse trigger delay.

¹² Also applies to other apertures that are integer multiples of 1PLC.

¹³ Recovery to within 20mV of previous level.

Specifications are subject to change without notice.

2306 Dual Channel Battery/Charger Simulator

OUTPUT #1 (BATTERY)

DC VOLTAGE OUTPUT (2 YEARS, 23°C ± 5°C)

OUTPUT VOLTAGE: 0 to +15VDC.
OUTPUT ACCURACY: ±(0.05% + 3mV).
PROGRAMMING RESOLUTION: 1mV.
READBACK ACCURACY¹: ±(0.05% + 3mV).
READBACK RESOLUTION: 1mV.
OUTPUT VOLTAGE SETTLING TIME: 5ms to within stated accuracy.
LOAD REGULATION: 0.01% + 2mV.
LINE REGULATION: 0.5mV.
STABILITY²: 0.01% + 0.5mV.
MEASUREMENT TIME CHOICES: 0.01 to 10 PLC⁷, in 0.01PLC steps.
AVERAGE READINGS: 1 to 10.
READING TIME^{1,8,9}: 31ms, typical.

TRANSIENT RESPONSE:	High Bandwidth	Low Bandwidth
Transient Recovery Time ¹³	<40µs ³ or <60µs ⁴	<80µs ³ or <100µs ⁴
Transient Voltage Drop	<75mV ³ or <100mV ⁴	<250mV ³ or <400mV ⁴

REMOTE SENSE 1V max. drop in each lead. Add 2mV to the voltage load regulation specification for each 1V change in the negative output lead due to load current change. Remote sense required. Integrity of connection continually monitored. If compromised, output will turn off automatically once settable window (±0 to ±8 volts) around normal voltage exceeded.

VARIABLE OUTPUT IMPEDANCE

RANGE: 0 to 1.00Ω in 0.01Ω steps. Value can be changed with output on.

DC CURRENT (2 Years, 23°C ± 5°C)

CONTINUOUS AVERAGE OUTPUT CURRENT:

Channel #2 (Charger) OFF:

$I = 50W / (V_{set} \text{ channel } 1 + 6V)$; 5A max.

Channel #2 (Charger) ON:

$I = (50W - \text{Power consumed by channel } \#2) / (V_{set} \text{ channel } 1 + 6V)$; 5A max.

The power consumed by channel #2 is calculated as:

Channel #2 sourcing current:

Power consumed = $(V_{set} \text{ channel } 2 + 6V) \times (\text{current supplied})$

Channel #2 sinking current:

Power consumed = $5 \times (\text{sink current})$

Peak currents can be a maximum of 5A provided the average current is within the above limits.

CONTINUOUS AVERAGE SINK CURRENT:

Channel #2 (Charger) OFF:

0–5V: 3A max.

5–15V: Derate 0.2A per volt above 5V. Compliance setting controls sinking.

Channel #2 (Charger) ON:

Available current = $(50W - \text{Power consumed by channel } \#2) / 5$; 3A max. (0–5V).

Derate 0.2A per volt above 5V.

SOURCE COMPLIANCE ACCURACY: ±(0.16% + 5mA)⁵.

PROGRAMMED SOURCE COMPLIANCE RESOLUTION: 1.25mA.

READBACK ACCURACY¹: 5A Range: ±(0.2% + 200µA).

5mA Range: ±(0.2% + 1µA).

READBACK RESOLUTION: 5A Range: 100µA.

5mA Range: 0.1µA.

LOAD REGULATION: 0.01% + 1mA.

LINE REGULATION: 0.5mA.

STABILITY⁴: 0.01% + 50µA.

MEASUREMENT TIME CHOICES: 0.01 to 10 PLC⁷, in 0.01PLC steps.

AVERAGE READINGS: 1 to 10.

READING TIME^{1,8,9}: 31ms, typical.

PULSE CURRENT MEASUREMENT OPERATION

TRIGGER LEVEL: 5A Range: 5mA to 5A, in 5mA steps.
1A Range: 1mA to 1A, in 1mA steps.
100mA Range: 0.1mA to 100mA, in 100µA steps.

TRIGGER DELAY: 0 to 100ms, in 10µs steps.

INTERNAL TRIGGER DELAY: 15µs.

HIGH/LOW/AVERAGE MODE:

Measurement Aperture Settings: 33.3µs to 833ms, in 33.3µs steps.

Average Readings: 1 to 100.

PULSE CURRENT MEASUREMENT ACCURACY¹¹ (2 Years, 23°C ± 5°C):

APERTURE	ACCURACY ±(% reading + offset + rms noise ¹⁰)
<100 µs	0.2% + 900 µA + 2 mA
100 µs – 200 µs	0.2% + 900 µA + 1.5mA
200 µs – 500 µs	0.2% + 900 µA + 1 mA
500 µs – <1 PLC	0.2% + 600 µA + 0.8mA
1 PLC ¹²	0.2% + 400 µA + 0 mA
>1 PLC	0.2% + 400 µA + 100 µA

BURST MODE CURRENT MEASUREMENT

MEASUREMENT APERTURE: 33.3µs.

CONVERSION RATE: 3650/second, typical.

INTERNAL TRIGGER DELAY: 15µs.

NUMBER OF SAMPLES: 1 to 5000.

TRANSFER SAMPLES ACROSS IEEE BUS IN BINARY MODE: 4800 bytes/s, typical.

LONG INTEGRATION MODE CURRENT MEASUREMENT

MEASUREMENT TIME⁶: 850ms (840ms) to 60 seconds in 1ms steps.

DIGITAL VOLTMETER INPUT (2 Years, 23°C ± 5°C)

INPUT VOLTAGE RANGE: –5 to +30VDC.

INPUT IMPEDANCE: 2MΩ typical.

MAXIMUM VOLTAGE (either input terminal) WITH RESPECT TO OUTPUT LOW: –5V, +30V.

READING ACCURACY¹: ±(0.05% + 3mV).

READING RESOLUTION: 1mV.

CONNECTOR: HI and LO input pair part of Output #1's terminal block.

MEASUREMENT TIME CHOICES: 0.01 to 10 PLC⁷, in 0.01PLC steps.

AVERAGE READINGS: 1 to 10.

READING TIME^{1,8,9}: 31ms, typical.

2306 Dual Channel Battery/Charger Simulator

OUTPUT #2 (CHARGER)

DC VOLTAGE OUTPUT (2 YEARS, 23°C ± 5°C)

OUTPUT VOLTAGE: 0 to +15VDC.

OUTPUT ACCURACY: ±(0.05% + 10mV).

PROGRAMMING RESOLUTION: 10mV.

READBACK ACCURACY¹: ±(0.05% + 3mV).

READBACK RESOLUTION: 1mV.

OUTPUT VOLTAGE SETTLING TIME: 5ms to within stated accuracy.

LOAD REGULATION: 0.01% + 2mV.

LINE REGULATION: 0.5mV.

STABILITY²: 0.01% + 0.5mV.

MEASUREMENT TIME CHOICES: 0.01 to 10 PLC⁷, in 0.01PLC steps.

AVERAGE READINGS: 1 to 10.

READING TIME^{1,8,9}: 31ms, typical.

TRANSIENT RESPONSE:	High Bandwidth	Low Bandwidth
Transient Recovery Time ¹³	<50µs ³ or <80µs ⁴	<60µs ³ or <100µs ⁴
Transient Voltage Drop	<120mV ³ or <150mV ⁴	<160mV ³ or <200mV ⁴

REMOTE SENSE: 1V max. drop in each lead. Add 2mV to the voltage load regulation specification for each 1V change in the negative output lead due to load current change. Remote sense required. Integrity of connection continually monitored. If compromised, output will turn off automatically once settable window (±0 to ±8 volts) around normal voltage exceeded.

DC CURRENT (2 Years, 23°C ± 5°C)

CONTINUOUS AVERAGE OUTPUT CURRENT:

Channel #1 (Battery) OFF:

I = 50W/(Vset channel 2 + 6V); 5A max.

Channel #1 (Battery) ON:

I = (50W – Power consumed by channel #1)/(Vset channel 2 + 6V); 5A max.

The power consumed by channel #1 is calculated as:

Channel #1 sourcing current:

Power consumed = (Vset channel 1 + 6V) × (current supplied)

Channel #1 sinking current:

Power consumed = 5 × (sink current)

Peak currents can be a maximum of 5A provided the average current is within the above limits.

CONTINUOUS AVERAGE SINK CURRENT:

Channel #1 (Battery) OFF:

0–5V: 3A max.

5–15V: Derate 0.2A per volt above 5V. Compliance setting controls sinking.

Channel #1 (Battery) ON:

Available current = (50W – Power consumed by channel #1)/5; 3A max. (0–5V).

Derate 0.2A per volt above 5V.

SOURCE COMPLIANCE ACCURACY: ±(0.16% + 5mA)⁵.

PROGRAMMED SOURCE COMPLIANCE RESOLUTION: 1.25mA.

READBACK ACCURACY¹: 5A Range: ±(0.2% + 200µA).

5mA Range: ±(0.2% + 1µA).

READBACK RESOLUTION: 5A Range: 100µA.

5mA Range: 0.1µA.

LOAD REGULATION: 0.01% + 1mA.

LINE REGULATION: 0.5mA.

STABILITY⁴: 0.01% + 50µA.

MEASUREMENT TIME CHOICES: 0.01 to 10 PLC⁷, in 0.01PLC steps.

AVERAGE READINGS: 1 to 10.

READING TIME^{1,8,9}: 31ms, typical.

PULSE CURRENT MEASUREMENT OPERATION

TRIGGER LEVEL: 5mA to 5A, in 5mA steps.

TRIGGER DELAY: 0 to 100ms, in 10µs steps.

INTERNAL TRIGGER DELAY: 15µs.

HIGH/LOW/AVERAGE MODE:

Measurement Aperture Settings: 33.3µs to 833ms, in 33.3µs steps.

Average Readings: 1 to 100.

PULSE CURRENT MEASUREMENT ACCURACY¹¹ (2 Years, 23°C ± 5°C):

APERTURE	ACCURACY ±(% reading + offset + rms noise ¹⁰)
<100 µs	0.2% + 900 µA + 2 mA
100 µs – 200 µs	0.2% + 900 µA + 1.5mA
200 µs – 500 µs	0.2% + 900 µA + 1 mA
500 µs – <1 PLC	0.2% + 600 µA + 0.8mA
1 PLC ¹²	0.2% + 400 µA + 0 mA
>1 PLC	0.2% + 400 µA + 100 µA

BURST MODE CURRENT MEASUREMENT

MEASUREMENT APERTURE: 33.3µs.

CONVERSION RATE: 2040/second, typical.

INTERNAL TRIGGER DELAY: 15µs.

NUMBER OF SAMPLES: 1 to 5000.

TRANSFER SAMPLES ACROSS IEEE BUS IN BINARY MODE: 4800 bytes/s, typical.

LONG INTEGRATION MODE CURRENT MEASUREMENT

MEASUREMENT TIME⁶: 850ms (840ms) to 60 seconds in 1ms steps.

DIGITAL VOLTMETER INPUT (2 Years, 23°C ± 5°C)

INPUT VOLTAGE RANGE: –5 to +30VDC.

INPUT IMPEDANCE: 2MΩ typical.

MAXIMUM VOLTAGE (either input terminal) WITH RESPECT TO OUTPUT LOW: –5V, +30V.

READING ACCURACY¹: ±(0.05% + 3mV).

READING RESOLUTION: 1mV.

CONNECTOR: HI and LO input pair part of Output #2's terminal block.

MEASUREMENT TIME CHOICES: 0.01 to 10 PLC⁷, in 0.01PLC steps.

AVERAGE READINGS: 1 to 10.

READING TIME^{1,8,9}: 31ms, typical.

2306 Dual Channel Battery/Charger Simulator

GENERAL

ISOLATION (low-earth): 22VDC max. Do not exceed 60VDC between any two terminals of either connector.

PROGRAMMING: IEEE-488.2 (SCPI).

USER-DEFINABLE POWER-UP STATES: 5.

REAR PANEL CONNECTORS: Two 8-position quick disconnect terminal block for output (4), sense (2), and DVM (2).

TEMPERATURE COEFFICIENT (outside 23°C ±5°C): Derate accuracy specification by $(0.1 \times \text{specification})/^\circ\text{C}$.

OPERATING TEMPERATURE: 0° to 50°C (Derate to 70%). 0° to 35°C (Full power).

STORAGE TEMPERATURE: -20° to 70°C.

HUMIDITY: <80% @ 35°C non-condensing.

DISPLAY TYPE: 2-line × 16 character VFD.

REMOTE DISPLAY/KEYPAD OPTION: Disables standard front panel.

DIMENSIONS: 89mm high × 213mm wide × 411mm deep (3½ in × 8¾ in × 16¾ in).

NET WEIGHT: 3.2kg (7.1 lbs).

SHIPPING WEIGHT: 5.4kg (12 lbs).

INPUT POWER: 100–120VAC/220–240VAC, 50 or 60Hz (auto detected at power-up).

POWER CONSUMPTION: 150VA max.

WARRANTY: Two years parts and labor on materials and workmanship.

EMC: Conforms with European Union Directive 89/336/EEC, EN 55011, EN 50082-1, EN 61000-3-2 and 61000-3-3, FCC part 15 class B.

SAFETY: Conforms with European Union Directive 73/23/EEC, EN 61010-1.

AC LINE LEAKAGE CURRENT: 450µA @ 110VAC, typ.; 600µA @ 220V, typ.

RELAY CONTROL PORT: 4-channel, each capable of 100mA sink, 24V max. Total port sink capacity (all 4 combined) is 250mA max. Accepts DB-9 male plug.

ACCESSORIES SUPPLIED: User and service manual, output connectors mating terminal (part no. CS-846).

ACCESSORIES AVAILABLE:

Model 2304-DISP: Remote LCD Display/Keypad (4.6 in × 2.7 in × 1.5 in). Includes 2.7m (9 ft) cable and rack mount kit.

¹ PLC = 1.00.

² Following 15 minute warm-up, the change in output over 8 hours under ambient temperature, constant load, and line operating conditions.

³ Remote sense, at output terminals, 0.5A to 5A typical.

⁴ Remote sense, with 4.5m (15 ft) of 16 gauge (1.31mm²) wire and 1Ω resistance in each lead to simulate typical test environment, 1.5A load change (0.15A to 1.65A).

⁵ Minimum current in constant current mode is 6mA.

⁶ 60Hz (50Hz).

⁷ PLC = Power Line Cycle. 1PLC = 16.7ms for 60Hz operation, 20ms for 50Hz operation.

⁸ Display off.

⁹ Speed includes measurement and binary data transfer out of GPIB.

¹⁰ Typical values, peak-to-peak noise equals 6 times rms noise.

¹¹ Based on settled signal: 100µs pulse trigger delay.

¹² Also applies to other apertures that are integer multiples of 1PLC.

¹³ Recovery to within 20mV of previous level.

Specifications are subject to change without notice.

2306-PJ Dual Channel Battery/Charger Simulator

OUTPUT #1 (BATTERY)

DC VOLTAGE OUTPUT (2 YEARS, 23°C ± 5°C)

OUTPUT VOLTAGE: 0 to +15VDC.

OUTPUT ACCURACY: ±(0.05% + 3mV).

PROGRAMMING RESOLUTION: 1mV.

READBACK ACCURACY¹: ±(0.05% + 3mV).

READBACK RESOLUTION: 1mV.

OUTPUT VOLTAGE SETTling TIME: 5ms to within stated accuracy.

LOAD REGULATION: 0.01% + 2mV.

LINE REGULATION: 0.5mV.

STABILITY²: 0.01% + 0.5mV.

MEASUREMENT TIME CHOICES: 0.01 to 10 PLC⁷, in 0.01PLC steps.

AVERAGE READINGS: 1 to 10.

READING TIME^{1,8,9}: 31ms, typical.

TRANSIENT RESPONSE:	High Bandwidth	Low Bandwidth
Transient Recovery Time ¹³	<40µs ³ or <60µs ⁴	<80µs ³ or <100µs ⁴
Transient Voltage Drop	<75mV ³ or <100mV ⁴	<250mV ³ or <400mV ⁴

REMOTE SENSE 1V max. drop in each lead. Add 2mV to the voltage load regulation specification for each 1V change in the negative output lead due to load current change. Remote sense required. Integrity of connection continually monitored. If compromised, output will turn off automatically once settable window (±0 to ±8 volts) around normal voltage exceeded.

VARIABLE OUTPUT IMPEDANCE

RANGE: 0 to 1.00Ω in 0.01Ω steps. Value can be changed with output on.

DC CURRENT (2 Years, 23°C ± 5°C)

CONTINUOUS AVERAGE OUTPUT CURRENT:

Channel #2 (Charger) OFF:

I = 50W/(Vset channel 1 + 6V); 5A max.

Channel #2 (Charger) ON:

I = (50W - Power consumed by channel #2)/(Vset channel 1 + 6V); 5A max.

The power consumed by channel #2 is calculated as:

Channel #2 sourcing current:

Power consumed = (Vset channel 2 + 6V) × (current supplied)

Channel #2 sinking current:

Power consumed = 5 × (sink current)

Peak currents can be a maximum of 5A provided the average current is within the above limits.

CONTINUOUS AVERAGE SINK CURRENT:

Channel #2 (Charger) OFF:

0-5V: 3A max.

5-15V: Derate 0.2A per volt above 5V. Compliance setting controls sinking.

Channel #2 (Charger) ON:

Available current = (50W - Power consumed by channel #2)/5; 3A max. (0-5V).

Derate 0.2A per volt above 5V.

SOURCE COMPLIANCE ACCURACY: ±(0.16% + 5mA)⁵.

PROGRAMMED SOURCE COMPLIANCE RESOLUTION: 1.25mA.

READBACK ACCURACY¹: 5A Range: ±(0.2% + 200µA).

500mA Range: ±(0.2% + 20µA).

READBACK RESOLUTION: 5A Range: 100µA.

500mA Range: 10µA.

LOAD REGULATION: 0.01% + 1mA.

LINE REGULATION: 0.5mA.

STABILITY⁴: 0.01% + 50µA.

MEASUREMENT TIME CHOICES: 0.01 to 10 PLC⁷, in 0.01PLC steps.

AVERAGE READINGS: 1 to 10.

READING TIME^{1,8,9}: 31ms, typical.

PULSE CURRENT MEASUREMENT OPERATION

TRIGGER LEVEL:

5A Current Range

5A Range: 5mA to 5A, in 5mA steps.

1A Range: 1mA to 1A, in 1mA steps.

100mA Range: 0.1mA to 100mA, in 100µA steps.

500mA Current Range

500mA Range: 0.5mA to 500mA, in 0.5mA steps.

100mA Range: 0.1mA to 100mA, in 100µA steps.

10mA Range: 100µA to 10mA, in 100µA steps.

TRIGGER DELAY: 0 to 100ms, in 10µs steps.

INTERNAL TRIGGER DELAY: 15µs.

HIGH/LOW/AVERAGE MODE:

Measurement Aperture Settings: 33.3µs to 833ms, in 33.3µs steps.

Average Readings: 1 to 100.

PULSE CURRENT MEASUREMENT ACCURACY¹¹ (2 Years, 23°C ± 5°C):

APERTURE	ACCURACY ±(% reading + offset + rms noise ¹⁰)	
	5A RANGE	500mA RANGE
<100 µs	0.2% + 900 µA + 2 mA	0.2% + 90 µA + 2 mA
100 µs – 200 µs	0.2% + 900 µA + 1.5 mA	0.2% + 90 µA + 1.5 mA
200 µs – 500 µs	0.2% + 900 µA + 1 mA	0.2% + 90 µA + 1 mA
500 µs – <1 PLC	0.2% + 600 µA + 0.8 mA	0.2% + 60 µA + 0.8 mA
1 PLC ¹²	0.2% + 400 µA + 0 mA	0.2% + 40 µA + 0 mA
>1 PLC	0.2% + 400 µA + 100 µA	0.2% + 40 µA + 100 µA

BURST MODE CURRENT MEASUREMENT

MEASUREMENT APERTURE: 33.3µs.

CONVERSION RATE: 3650/second, typical.

INTERNAL TRIGGER DELAY: 15µs.

NUMBER OF SAMPLES: 1 to 5000.

TRANSFER SAMPLES ACROSS IEEE BUS IN BINARY MODE: 4800 bytes/s, typical.

LONG INTEGRATION MODE CURRENT MEASUREMENT

Available on both 5A and 500mA current ranges.

MEASUREMENT TIME⁶: 850ms (840ms) to 60 seconds in 1ms steps.

DIGITAL VOLTMETER INPUT (2 Years, 23°C ± 5°C)

INPUT VOLTAGE RANGE: -5 to +30VDC.

INPUT IMPEDANCE: 2MΩ typical.

MAXIMUM VOLTAGE (either input terminal) WITH RESPECT TO OUTPUT LOW: -5V, +30V.

READING ACCURACY¹: ±(0.05% + 3mV).

READING RESOLUTION: 1mV.

CONNECTOR: HI and LO input pair part of Output #1's terminal block.

MEASUREMENT TIME CHOICES: 0.01 to 10 PLC⁷, in 0.01PLC steps.

AVERAGE READINGS: 1 to 10.

READING TIME^{1,8,9}: 31ms, typical.

2306-PJ Dual Channel Battery/Charger Simulator

OUTPUT #2 (CHARGER)

DC VOLTAGE OUTPUT (2 YEARS, 23°C ± 5°C)

OUTPUT VOLTAGE: 0 to +15VDC.

OUTPUT ACCURACY: ±(0.05% + 10mV).

PROGRAMMING RESOLUTION: 10mV.

READBACK ACCURACY¹: ±(0.05% + 3mV).

READBACK RESOLUTION: 1mV.

OUTPUT VOLTAGE SETTling TIME: 5ms to within stated accuracy.

LOAD REGULATION: 0.01% + 2mV.

LINE REGULATION: 0.5mV.

STABILITY²: 0.01% + 0.5mV.

MEASUREMENT TIME CHOICES: 0.01 to 10 PLC⁷, in 0.01PLC steps.

AVERAGE READINGS: 1 to 10.

READING TIME^{1,8,9}: 31ms, typical.

TRANSIENT RESPONSE:	High Bandwidth	Low Bandwidth
Transient Recovery Time¹³	<50µs ³ or <80µs ⁴	<60µs ³ or <100µs ⁴
Transient Voltage Drop	<120mV ³ or <150mV ⁴	<160mV ³ or <200mV ⁴

REMOTE SENSE: 1V max. drop in each lead. Add 2mV to the voltage load regulation specification for each 1V change in the negative output lead due to load current change. Remote sense required. Integrity of connection continually monitored. If compromised, output will turn off automatically once settable window (±0 to ±8 volts) around normal voltage exceeded.

DC CURRENT (2 Years, 23°C ± 5°C)

CONTINUOUS AVERAGE OUTPUT CURRENT:

Channel #1 (Battery) OFF:

$I = 50W / (V_{set} \text{ channel } 2 + 6V)$; 5A max.

Channel #1 (Battery) ON:

$I = (50W - \text{Power consumed by channel } \#1) / (V_{set} \text{ channel } 2 + 6V)$; 5A max.

The power consumed by channel #1 is calculated as:

Channel #1 sourcing current:

Power consumed = $(V_{set} \text{ channel } 1 + 6V) \times (\text{current supplied})$

Channel #1 sinking current:

Power consumed = $5 \times (\text{sink current})$

Peak currents can be a maximum of 5A provided the average current is within the above limits.

CONTINUOUS AVERAGE SINK CURRENT:

Channel #1 (Battery) OFF:

0–5V: 3A max.

5–15V: Derate 0.2A per volt above 5V. Compliance setting controls sinking.

Channel #1 (Battery) ON:

Available current = $(50W - \text{Power consumed by channel } \#1) / 5$; 3A max. (0–5V).

Derate 0.2A per volt above 5V.

SOURCE COMPLIANCE ACCURACY: ±(0.16% + 5mA)⁵.

PROGRAMMED SOURCE COMPLIANCE RESOLUTION: 1.25mA.

READBACK ACCURACY¹: **5A Range:** ±(0.2% + 200µA).

5mA Range: ±(0.2% + 1µA).

READBACK RESOLUTION: **5A Range:** 100µA.

5mA Range: 0.1µA.

LOAD REGULATION: 0.01% + 1mA.

LINE REGULATION: 0.5mA.

STABILITY⁴: 0.01% + 50µA.

MEASUREMENT TIME CHOICES: 0.01 to 10 PLC⁷, in 0.01PLC steps.

AVERAGE READINGS: 1 to 10.

READING TIME^{1,8,9}: 31ms, typical.

PULSE CURRENT MEASUREMENT OPERATION

TRIGGER LEVEL: 5mA to 5A, in 5mA steps.

TRIGGER DELAY: 0 to 100ms, in 10µs steps.

INTERNAL TRIGGER DELAY: 15µs.

HIGH/LOW/AVERAGE MODE:

Measurement Aperture Settings: 33.3µs to 833ms, in 33.3µs steps.

Average Readings: 1 to 100.

PULSE CURRENT MEASUREMENT ACCURACY¹¹ (2 Years, 23°C ± 5°C):

APERTURE	ACCURACY ±(% reading + offset + rms noise ¹⁰)
<100 µs	0.2% + 900 µA + 2 mA
100 µs – 200 µs	0.2% + 900 µA + 1.5mA
200 µs – 500 µs	0.2% + 900 µA + 1 mA
500 µs – <1 PLC	0.2% + 600 µA + 0.8mA
1 PLC ¹²	0.2% + 400 µA + 0 mA
>1 PLC	0.2% + 400 µA + 100 µA

BURST MODE CURRENT MEASUREMENT

MEASUREMENT APERTURE: 33.3µs.

CONVERSION RATE: 2040/second, typical.

INTERNAL TRIGGER DELAY: 15µs.

NUMBER OF SAMPLES: 1 to 5000.

TRANSFER SAMPLES ACROSS IEEE BUS IN BINARY MODE: 4800 bytes/s, typical.

LONG INTEGRATION MODE CURRENT MEASUREMENT

MEASUREMENT TIME⁶: 850ms (840ms) to 60 seconds in 1ms steps.

DIGITAL VOLTMETER INPUT (2 Years, 23°C ± 5°C)

INPUT VOLTAGE RANGE: –5 to +30VDC.

INPUT IMPEDANCE: 2MΩ typical.

MAXIMUM VOLTAGE (either input terminal) WITH RESPECT TO OUTPUT LOW: –5V, +30V.

READING ACCURACY¹: ±(0.05% + 3mV).

READING RESOLUTION: 1mV.

CONNECTOR: HI and LO input pair part of Output #2's terminal block.

MEASUREMENT TIME CHOICES: 0.01 to 10 PLC⁷, in 0.01PLC steps.

AVERAGE READINGS: 1 to 10.

READING TIME^{1,8,9}: 31ms, typical.

2306-PJ Dual Channel Battery/Charger Simulator

GENERAL

ISOLATION (low-earth): 22VDC max. Do not exceed 60VDC between any two terminals of either connector.

PROGRAMMING: IEEE-488.2 (SCPI).

USER-DEFINABLE POWER-UP STATES: 4.

REAR PANEL CONNECTORS: Two 8-position quick disconnect terminal block for output (4), sense (2), and DVM (2).

TEMPERATURE COEFFICIENT (outside 23°C ±5°C): Derate accuracy specification by $(0.1 \times \text{specification})/^\circ\text{C}$.

OPERATING TEMPERATURE: 0° to 50°C (Derate to 70%). 0° to 35°C (Full power).

STORAGE TEMPERATURE: -20° to 70°C.

HUMIDITY: <80% @ 35°C non-condensing.

DISPLAY TYPE: 2-line × 16 character VFD.

REMOTE DISPLAY/KEYPAD OPTION: Disables standard front panel.

DIMENSIONS: 89mm high × 213mm wide × 411mm deep (3½ in × 8¾ in × 16¾ in).

NET WEIGHT: 3.2kg (7.1 lbs).

SHIPPING WEIGHT: 5.4kg (12 lbs).

INPUT POWER: 100–120VAC/220–240VAC, 50 or 60Hz (auto detected at power-up).

POWER CONSUMPTION: 150VA max.

WARRANTY: Two years parts and labor on materials and workmanship.

EMC: Conforms with European Union Directive directive 89/336/EEC.

SAFETY: Conforms with European Union Directive 73/23/EEC.

AC LINE LEAKAGE CURRENT: 450µA @ 110VAC, typ.; 600µA @ 220V, typ.

RELAY CONTROL PORT: 4-channel, each capable of 100mA sink, 24V max. Total port sink capacity (all 4 combined) is 250mA max. Accepts DB-9 male plug.

ACCESSORIES SUPPLIED: User and service manual, output connectors mating terminal (part no. CS-846).

ACCESSORIES AVAILABLE:

Model 2304-DISP: Remote LCD Display/Keypad (4.6 in × 2.7 in × 1.5 in). Includes 2.7m (9 ft) cable and rack mount kit.

¹ PLC = 1.00.

² Following 15 minute warm-up, the change in output over 8 hours under ambient temperature, constant load, and line operating conditions.

³ Remote sense, at output terminals, 0.5A to 5A typical.

⁴ Remote sense, with 4.5m (15 ft) of 16 gauge (1.31mm²) wire and 1Ω resistance in each lead to simulate typical test environment, 1.5A load change (0.15A to 1.65A).

⁵ Minimum current in constant current mode is 6mA.

⁶ 60Hz (50Hz).

⁷ PLC = Power Line Cycle. 1PLC = 16.7ms for 60Hz operation, 20ms for 50Hz operation.

⁸ Display off.

⁹ Speed includes measurement and binary data transfer out of GPIB.

¹⁰ Typical values, peak-to-peak noise equals 6 times rms noise.

¹¹ Based on settled signal: 100µs pulse trigger delay.

¹² Also applies to other apertures that are integer multiples of 1PLC.

¹³ Recovery to within 20mV of previous level.

Specifications are subject to change without notice.

B

Error and Status Messages

Table B-1
Error and status messages

Number	Description	Event
-440	Query unterminated after indefinite response	EE
-430	Query deadlocked	EE
-420	Query unterminated	EE
-410	Query interrupted	EE
-363	Input buffer overrun	SYS
-350	Queue overflow	SYS
-330	Self-test failed	EE
-314	Save/recall memory lost	EE
-315	Configuration memory lost	EE
-260	Expression error	EE
-241	Hardware missing	EE
-230	Data corrupt or stale	EE
-225	Out of memory	EE
-224	Illegal parameter value	EE
-223	Too much data	EE
-222	Parameter data out of range	EE
-221	Settings conflict	EE
-220	Parameter error	EE
-200	Execution error	EE
-178	Expression data not allowed	EE
-171	Invalid expression	EE
-170	Expression error	EE
-161	Invalid block data	EE
-160	Block data error	EE
-158	String data not allowed	EE
-154	String too long	EE
-151	Invalid string data	EE
-150	String data error	EE

EE = error event

SE = status event

SYS = system error event

Table B-1
Error and status messages (cont.)

Number	Description	Event
-148	Character data not allowed	EE
-144	Character data too long	EE
-141	Invalid character data	EE
-140	Character data error	EE
-124	Too many digits	EE
-123	Exponent too large	EE
-121	Invalid character in number	EE
-120	Numeric data error	EE
-114	Header suffix out of range	EE
-113	Undefined header	EE
-112	Program mnemonic too long	EE
-111	Header separator error	EE
-110	Command header error	EE
-109	Missing parameter	EE
-108	Parameter not allowed	EE
-105	GET not allowed	EE
-104	Data type error	EE
-103	Invalid separator	EE
-102	Syntax error	EE
-101	Invalid character	EE
-100	Command error	EE
+000	No error	SE
pt+101	Operation complete	SE
+301	Reading overflow battery channel	SE
+302	Pulse trigger detection timeout battery channel	SE
+306	Reading available battery channel	SE
+307	Reading overflow charger channel	SE
+308	Pulse trigger detection timeout charger channel	SE
+309	Reading available charger channel	SE
+310	Buffer full battery channel	SE
+311	Buffer full charger channel	SE
+320	Current limit event battery channel	SE
+321	Current limit tripped event battery channel	SE
+322	Heatsink shutdown event	SE
+323	Power supply shutdown event	SE
+324	Current limit event charger channel	SE
+325	Current limit tripped event charger channel	SE
+326	Overvoltage protection	SE
+327	Overvoltage protection	SE

EE = error event

SE = status event

SYS = system error event

Table B-1
Error and status messages (cont.)

Number	Description	Event
	Calibration messages:	
+404	Volt full scale cal prepare error battery channel	EE
+405	Volt full scale cal output error battery channel	EE
+406	Volt full scale cal meas error battery channel	EE
+407	DVM full scale cal meas error battery channel	EE
+409	Amp source cal prepare error battery channel	EE
+410	Amp source cal output error battery channel	EE
+411	Amp source cal measure error battery channel	EE
+412	mA source cal prepare error battery channel	EE
+413	mA source cal measure error battery channel	EE
+424	Volt full scale cal prepare error charger channel	EE
+425	Volt full scale cal output error charger channel	EE
+426	Volt full scale cal meas error charger channel	EE
+427	DVM full scale cal meas error charger channel	EE
+429	Amp source cal prepare error charger channel	EE
+430	Amp source cal output error charger channel	EE
+431	Amp source cal measure error charger channel	EE
+432	mA source cal prepare error charger channel	EE
+433	mA source cal measure error charger channel	EE
+438	Date of calibration not set	EE
+440	Gain-aperture correction error	EE
+500	Calibration data invalid	EE
+510	Reading buffer data lost	EE
+511	GPIB address lost	EE
+512	Power-on state lost	EE
+514	DC Calibration data lost	EE
+515	Calibration dates lost	EE
+522	GPIB communication data lost	EE
+610	Questionable calibration	SE
+900	Internal system error	EE

EE = error event

SE = status event

SYS = system error event

C Calibration Reference

Introduction

This appendix contains detailed information on the various Model 2306 remote calibration commands, calibration error messages, and methods to detect the end of each calibration step.

Section 13 of this manual covers detailed calibration procedures.

Command summary

Table C-1 summarizes calibration commands. These commands are covered in detail in the following paragraphs.

Miscellaneous commands

Miscellaneous commands are those commands that perform such functions as saving calibration constants, locking out calibration, and programming date parameters.

:CODE

(:CALibration:PROTECTED:CODE)

Purpose	To unlock calibration so that you can perform the calibration procedure.
Format	:cal:prot:code '<code>'
Parameter	Up to an 8-character ASCII string, including letters and numbers.
Description	The :CODE command sends the calibration code and enables calibration when performing these procedures via remote. The correct code must be sent to the unit before sending any other calibration command. The default remote code is KI002306.
Notes	<p>The :CODE command should be sent only once before performing calibration. Do not send :CODE before each calibration step.</p> <p>To change the code, first send the present code then send the new code.</p> <p>The code parameter must be enclosed in single quotes.</p>
Example	:CAL:PROT:CODE 'KI002306' Send default code of KI002306.

Table C-1
Remote calibration command summary

Command	Description
:CALibration	Calibration subsystem.
:PROTected	Cal commands protected by password.
:CODE '<code>'	Unlock cal; changes code if cal is already unlocked. (Default code: KI002306.)
:COUNT?	Query number of times 2306 has been calibrated.
:DATE <yyyy>,<mm>,<dd>	Program calibration year, month, day.
:DATE?	Query calibration year, month, day.
:INIT	Initiate calibration (must be sent before other cal steps).
:SAVE	Save calibration data to EEPROM.*
:LOCK	Lock out calibration. (Abort if calibration is incomplete.)
:STEP0 <nrf>	Output Ch. 1 full-scale voltage (14V).
:STEP1 <nrf>	Calibrate Ch. 1 output voltage using external DMM reading.
:STEP2 <nrf>	Calibrate Ch. 1 voltage measuring using external DMM reading.
:STEP3	Perform Ch. 1 DVM input full-scale (14V) cal.
:STEP4 <nrf>	Output current (1.9A) for Ch. 1 5A full-scale cal.
:STEP5 <nrf>	Calibrate Ch. 1 output current limit using calculated current.
:STEP6 <nrf>	Calibrate Ch. 1 5A measurement range using calculated current.
:STEP7	Output 5mA nominal current for Ch. 1 5mA range full-scale cal.
:STEP8 <nrf>	Calibrate Ch. 1 5mA measurement range.
:STEP9 <nrf>	Output Ch. 2 full-scale voltage (14V).
:STEP10 <nrf>	Calibrate Ch. 2 output voltage setting using DMM reading.
:STEP11 <nrf>	Calibrate Ch. 2 voltage measuring using external DMM reading.
:STEP12	Perform Ch. 2 DVM input full-scale (14V) cal.
:STEP13 <nrf>	Output current (1.9A) for Ch. 2 5A full-scale cal.
:STEP14 <nrf>	Calibrate Ch. 2 output current limit using calculated current.
:STEP15 <nrf>	Calibrate Ch. 2 5A measurement range using calculated current.
:STEP16	Output 5mA nominal current for Ch. 2 5mA range full-scale cal.
:STEP17 <nrf>	Calibrate Ch. 2 5mA measurement range.

* Calibration data will not be saved if:

1. Calibration was not unlocked with :CODE command.
2. Invalid data exists. (For example, cal step failed or was aborted.)
3. Incomplete number of cal steps were performed.
4. Calibration was not performed in the proper sequence.

:COUNT?**(:CALibration:PROTected:COUNT?)**

Purpose	To request the number of times the Model 2306 has been calibrated.	
Format	:cal:prot:count?	
Response	Number of times calibrated.	
Description	The :COUNT? query may be used to determine the total number of times the Model 2306 has been calibrated. The calibration count will also be displayed during the front panel calibration procedure.	
Example	:CAL:PROT:COUNT?	Request calibration count.

:DATE**(:CALibration:PROTected:DATE)**

Purpose	To program the calibration date.	
Format	:cal:prot:date <yyyy>, <mm>, <dd>	
Parameters	<yyyy> = 1998 to 2097 <mm> = 1 to 12 <dd> = 1 to 31	
Query	:cal:prot:date?	
Response	<yyyy>, <mm>, <dd>	
Description	The :DATE command allows you to store the calibration date in instrument EEROM for future reference. You can read back the date from the instrument by using the :DATE? query. The calibration date will also be displayed during the front panel calibration procedure.	
Note	The year, month, and day parameters must be delimited by commas.	
Example	:CAL:PROT:DATE 1998,11,20	Send cal date (11/20/98).

:INIT**(:CALibration:PROTected:INIT)**

Purpose	To initiate calibration.	
Format	:cal:prot:init	
Description	The :INIT command initiates the calibration process and must be sent before all other commands except :CODE.	
Note	The :INIT command should be sent only once at the beginning of the calibration procedure. Do not send :INIT before each calibration step.	
Example	:CAL:PROT:INIT	Initiate calibration.

:SAVE**(:CALibration:PROTected:SAVE)**

Purpose	To save calibration constants in EEROM after the calibration procedure.	
Format	:cal:prot:save	
Description	The :SAVE command stores internally calculated calibration constants derived during comprehensive in EEROM. EEROM is non-volatile memory, and calibration constants will be retained indefinitely once saved. :SAVE is sent after all other calibration steps.	
Note	Calibration will be only temporary unless the :SAVE command is sent to permanently store calibration constants. Calibration data will not be saved if: <ol style="list-style-type: none"> 1. Calibration was not unlocked by sending the :CODE command 2. Invalid data exists (for example, cal step failed). 3. An incomplete number of cal steps were performed. 4. Calibration was performed out of sequence. 	
Example	:CAL:PROT:SAVE	Save calibration constants

:STEP**(:CALibration:PROTected:STEP<n>)**

Purpose	To perform various calibration steps.	
Format	:cal:prot:step<n>	
Parameters	See Table C-1 on page C-3.	
Description	The :CAL:PROT:STEP<n> command performs calibration at the various points listed in Table C-2. See <i>Section 13</i> for details on test equipment and connections.	
Note	Calibration steps must be performed in the order listed in Table C-2, or an error will occur.	
Example	:CAL:PROT:STEP0 14	Perform cal step 0 (Ch. 1 full-scale output).

Detecting calibration errors

If an error occurs during any calibration step, the Model 2306 will generate an appropriate error message. Several methods to detect calibration errors are discussed below.

Reading the error queue

As with other Model 2306 errors, any calibration errors will be reported in the error queue. Use the `:SYST:ERR?` query to read the error queue.

Error summary

Table C-2 summarizes calibration errors.

Status byte EAV (Error Available) bit

Whenever an error is available in the error queue, the EAV (Error Available) bit (bit 2) of the status byte will be set. Use the `*STB?` query to obtain the status byte, then test bit 2 to see if it is set. If the EAV bit is set, an error has occurred, and you can use the appropriate error query to read the error and at the same time clear the EAV bit in the status byte.

Generating an SRQ on error

To program the instrument to generate an IEEE-488 bus SRQ (Service Request) when an error occurs, send the following command: `*SRE 4`. This command will enable SRQ when the EAV bit is set. You can then read the status byte and error queue as outlined above to check for errors and to determine the exact nature of the error.

Table C-2
Calibration errors

Error number	Error message
+404	Volt fullscale cal prepare error chan 1
+405	Volt fullscale cal output error chan 1
+406	Volt fullscale cal meas error chan 1
+407	DVM full scale cal meas error chan 1
+409	5 Amp source cal prepare error chan 1
+410	5 Amp source cal output error chan 1
+411	5 Amp source cal measure error chan 1
+412	5 mA source cal prepare error chan 1
+413	5 mA source cal measure error chan 1
+414	Cal error - trigger level gain chan 1
+415	Cal error - trigger level offset chan 1
+416	Cal error - t lev amp offset chan 1
+424	Volt fullscale cal prepare error chan 2
+425	Volt fullscale cal output error chan 2
+426	Volt fullscale cal meas error chan 2
+427	DVM full scale cal meas error chan 2
+429	5 Amp source cal prepare error chan 2
+430	5 Amp source cal output error chan 2
+431	5 Amp source cal measure error chan 2
+432	5 mA source cal prepare error chan 2
+433	5 mA source cal measure error chan 2
+434	Cal error - trigger level gain chan 2
+435	Cal error - trigger level offset chan 2
+436	Cal error - t lev amp offset chan 2

Detecting calibration step completion

When sending remote calibration commands, you must wait until the instrument completes the current operation before sending another command. You can use either `*OPC` or `*OPC?` to determine when each calibration step is completed.

Using the `*OPC` command

Using `*OPC` is the preferred method to detect the end of each calibration step. To use `*OPC`, do the following:

1. Enable operation complete by sending `*ESE 1`. This command sets the OPC (operation complete bit) in the standard event enable register, allowing operation complete status from the standard event status register to set the ESB (event summary bit) in the status byte when operation complete is detected.
2. Send the `*OPC` command immediately following each calibration command. For example:

```
:CAL:PROT:STEP0 14;*OPC
```

Note that you must include the semicolon (;) to separate the two commands, and that the `*OPC` command must appear on the same line as the command.

3. After sending a calibration command, repeatedly test the ESB (Event Summary) bit (bit 5) in the status byte until it is set. (Use `*STB?` to request the status byte.)
4. Once operation complete has been detected, clear OPC status using one of two methods: (1) use the `*ESR?` query, then read the response to clear the standard event status register, or (2) send the `*CLS` command to clear the status registers. Note that sending `*CLS` will also clear the error queue and operation complete status.

Using the `*OPC?` query

With the `*OPC?` (operation complete) query, the instrument will place an ASCII 1 in the output queue when it has completed each step. To determine when the OPC response is ready, do the following:

1. Send the `*OPC?` query immediately following each calibration command. For example:

```
:CAL:PROT:STEP0 14;*OPC?
```
2. Wait for an ASCII 1 to be read from the unit after addressing it to talk.

Generating an SRQ on calibration complete

An IEEE-488 bus SRQ (service request) can be used to detect operation complete instead of repeatedly polling the Model 2306. To use this method, send both `*ESE 1` and `*SRE 32` to the instrument, then include the `*OPC` command at the end of each calibration command line, as covered above. Clear the SRQ by querying the ESR (using the `*ESR?` query) to clear OPC status, then request the status byte with the `*STB?` query to clear the SRQ.

Refer to your controller's documentation for information on detecting and servicing SRQs.

D Calibration Program

Introduction

This appendix includes a calibration program written in BASIC to help you in calibrating the Model 2306. Refer to *Section 13* for more details on calibration procedures, equipment, and connections. *Appendix C* covers calibration commands in detail.

Computer hardware requirements

The following computer hardware is required to run the calibration programs:

- IBM PC compatible computer.
- Keithley KPC-488.2 or KPC-488.2AT, or CEC PC-488 IEEE-488 interface for the computer.
- Two shielded IEEE-488 bus cables (Keithley Model 7007).

Software requirements

To use the calibration program, you will need the following computer software:

- Microsoft QBasic (supplied with MS-DOS 5.0 or later).
- MS-DOS version 5.0 or later.
- HP-style Universal Language Driver, CECHP.EXE (supplied with Keithley and CEC interface cards listed above).

Calibration equipment

The following calibration equipment is required:

- Keithley Model 2001 Digital Multimeter
- 4 Ω , 0.1%, 100W resistor
- 3k Ω , 0.1%, 0.25W resistor

Refer to *Section 13* for detailed equipment specifications as well as details on test connections.

General program instructions

Follow the steps below to use the example calibration program, which calibrates both Channel #1 and Channel #2.

1. With the power off, connect the Model 2306 and the digital multimeter to the IEEE-488 interface of the computer. Be sure to use shielded IEEE-488 cables for bus connections.
2. Turn on the computer, the Model 2306, and the digital multimeter. Allow the Model 2306 and the multimeter to warm up for at least one hour before performing calibration.
3. Make sure the Model 2306 is set for a primary address of 16.
4. Make sure the digital multimeter primary address is set to 17.
5. Make sure that the computer bus driver software (CECHP.EXE) is properly initialized.
6. Enter the QBasic editor, and type in Program C-1. Be sure to use the actual characterized resistor values when entering the parameters.
7. Check thoroughly for errors, then save the program using a convenient filename.
8. Run the program, and follow the prompts on the screen to perform calibration. For test connections, refer to the following figures in Section 13:
 - Voltage connections: Figure 13-1.
 - 5A current connections: Figure 13-2.
 - 5mA current connections: Figure 13-3.

Program D-1

Model 2306 calibration program

```
' Model 2306 calibration program for using Keithley Model 2001 DMM.
' Rev. 1.0, 3/15/98
' 2306 primary address = 16. 2001 primary address = 17.
OPEN "IEEE" FOR OUTPUT AS #1      ' Open IEEE-488 output path.
OPEN "IEEE" FOR INPUT AS #2      ' Open IEEE-488 input path.
PRINT #1, "INTERM CRLF"          ' Set input terminator.
PRINT #1, "OUTTERM LF"           ' Set output terminator.
PRINT #1, "REMOTE 16 17"         ' Put 2306, 2001 in remote.
PRINT #1, "OUTPUT 16;*CLS"       ' Initialize 2306.
PRINT #1, "OUTPUT 16;*ESE 1;*SRE 32" ' Enable OPC and SRQ.
PRINT #1, "OUTPUT 17::SYST:PRES" ' Initialize 2001.
PRINT #1, "OUTPUT 17::FORM:ELEM READ" ' Reading only.
C$ = ":CAL:PROT:STEP"            ' Partial command header.
FourOhm = 4                       ' Use characterized 4 ohm value.
ThreeK = 3000                     ' Use characterized 3 k ohm value.
CLS
PRINT "Model 2306 Calibration Program"
PRINT #1, "OUTPUT 16::CAL:PROT:CODE 'KI002306'" 'Unlock calibration.
PRINT #1, "OUTPUT 16::CAL:PROT:INIT"          ' Initiate calibration.
GOSUB ErrCheck
GOSUB KeyCheck
FOR I = 0 TO 17 ' Loop for all cal steps.
```



```
ErrCheck:                                ' Error check routine.
PRINT #1, "OUTPUT 16;;SYST:ERR?"
PRINT #1, "ENTER 16"
INPUT #2, E, Err$
IF E <> 0 THEN PRINT Err$: GOTO EndProg
RETURN
'
ReadDMM:                                  ' Get reading from DMM.
SLEEP 5
PRINT #1, "OUTPUT 17;;FETCH?"
PRINT #1, "ENTER 17"
INPUT #2, Reading$
IF I = 5 OR I = 6 OR I = 14 OR I = 15 THEN Reading$ = STR$(VAL(Reading$) / FourOhm)
IF I = 8 OR I = 17 THEN Reading$ = STR$(VAL(Reading$) / ThreeK)
RETURN
'
EndProg:                                  ' Close files, end program.
BEEP: PRINT "Calibration aborted."
PRINT #1, "OUTPUT 16;;CAL:PROT:LOCK"
PRINT #1, "LOCAL 16 17"
CLOSE
END
Messages:
DATA "On Ch. 1 Connect DMM volts input to SOURCE, SENSE, and DVM IN terminals."
DATA "On Ch. 1 Connect DMM volts input and 4 ohm resistor to SOURCE and SENSE."
DATA "On Ch. 1 Connect DMM volts input and 3 k ohm resistor to SOURCE and SENSE."

DATA "On Ch. 2 Connect DMM volts input to SOURCE, SENSE, and DVM IN terminals."
DATA "On Ch. 2 Connect DMM volts input and 4 ohm resistor to SOURCE and SENSE."
DATA "On Ch. 2 Connect DMM volts input and 3 k ohm resistor to SOURCE and SENSE."
```

E Applications Guide

NOTES *This manual covers Keithley Models 2302, 2302-PJ, 2306, and 2306-PJ simulators (power supplies). Since the Model 2302 and 2302-PJ are single channel battery simulators, functions related to the second channel (i.e., the charger channel) are not available for the Model 2302 and 2302-PJ. Therefore:*

- *battery and charger channel features contained in this manual apply for the Model 2306 and 2306-PJ*
- *only battery channel features contained in this manual apply for the Model 2302 and 2302-PJ*

Refer to Appendix F for specific Model 2302 and 2302-PJ information.

Information contained in this section applies to all power supply channels (unless otherwise noted). In this manual, channel 1 refers to the battery channel while channel 2 refers to the charger channel (2306 and 2306-PJ feature only).

Simulating battery impedance

Variable output impedance control on channel #1

The electronic resistance of batteries varies according to a variety of factors such as but not limited to chemistry, cell construction, number of charge/discharge cycles, temperature, and depth of discharge. If a battery is used as a source in a circuit with a dynamic load, changes in the voltage across the load will be produced proportional to the electronic resistance of the battery and other sources of resistance in the circuit. If the peak load current is high enough or the electronic resistance of the battery and the resistance between the source and the DUT is large, the voltage drop will compromise the performance of the device.

This phenomenon occurs in TDMA and GSM cellular handsets where the magnitude of the “ON/OFF” current during transmission varies by as much as a factor of 20. In the absence of any filtering capacitance between the battery and the RF power amplifier, the handset will shut-off if the supply voltage is below the operating threshold for periods as short as several microseconds.

Figure E-1 shows a simple schematic of a battery, represented by an ideal voltage source, V_{cell} , the internal impedance, $R_i(t)$, connected to a DUT with interconnects having a resistance $R_{\text{interconnect}}$.

Figure E-1
Battery schematic

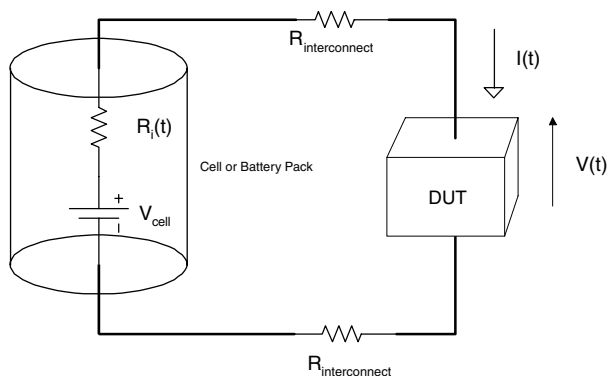

If $R_{\text{interconnect}}$ is small compared to $R_i(t)$ and $R_i(t)$ is relatively constant during the length of the pulse, $R_i(t) \sim R_i$, then the voltage across the DUT may be expressed as:

$$V(t) = V_i - I(t)R_i$$

where: $I(t)$ is the time varying current through the battery.

Figure E-2 shows the actual performance of typical LI, NiMH, and NiCd handset battery packs with a dynamic load, shown in Figure E-3, simulating a GSM handset during transmission. The pulse minimum voltage is the voltage at the battery terminals during the transmit, or high current portion, of the data frame. The average battery voltage is the voltage across the terminals measured with a 6½ digit DMM at approximately 50 readings per second. The figure shows the pulse minimum voltage reaches the shutdown threshold, 5.7V, before average battery voltage. The difference between the pulse minimum and average battery voltage also varies as a function of the electronic resistance with time, shown in Figure E-4 of the battery packs and ranges between 200–500mV. The results of these measurements prove that the impedance of the battery must be considered when evaluating handset performance, especially near the end of life for the battery pack.

NOTE Figure E-2 shows the average and minimum battery pack terminal voltage during a load pulse from a dynamic load simulating a GSM phone.

Figure E-2

Actual battery pack terminal voltage during GSM phone simulation

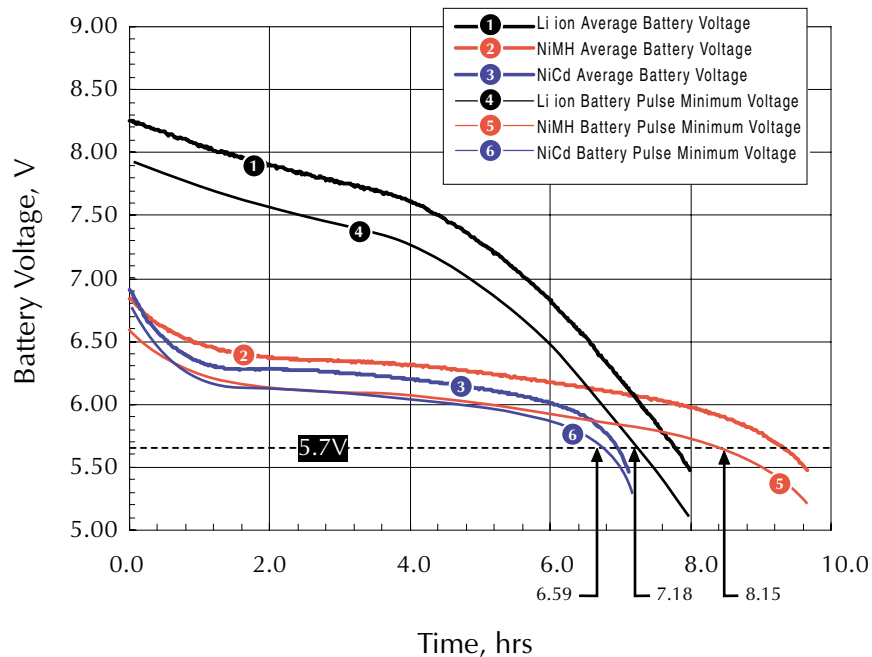
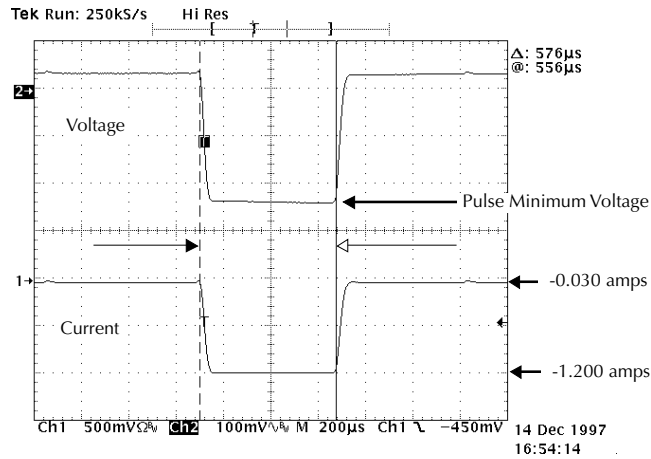

Figure E-3
 Simulated GSM phone current profile



NOTE The simulated GSM phone current profile contained in Figure E-3 shows a standby current of 0.030A, a transmit current of 1.2A, and the pulse minimum voltage during the transmit frame.

Channel #1 of the Model 2306 has a variable output impedance control that can be used to simulate the impedance of a battery pack. The output impedance may be set from 0.00Ω (default condition) to 1.00Ω in 0.01Ω increments from the front panel or over the GPIB bus.

Figure E-4
 Electronic resistance of NiCd, NiMH, and Li ion battery packs

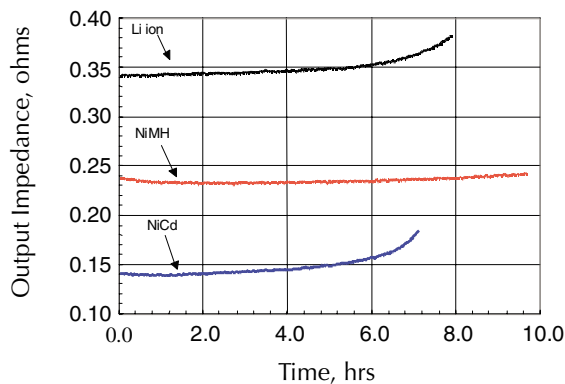

NOTE Figure E-4 shows electronic resistance for battery packs during a simulated GSM phone pulsed discharge from full charge to 5.5 volts.

Figure E-5 shows the output voltage and current response of channel #1 with a GSM phone for output impedance values of 0.00Ω , 0.05Ω , and 0.10Ω . The voltage drop, 70mV in E-5c and 140mV in E-5e, is approximately equal to the dynamic load current, 1.4A , multiplied by the output impedance, E-5c (0.05Ω) and E-5e (0.10Ω).

Figure E-5
Effect of the variable output impedance control

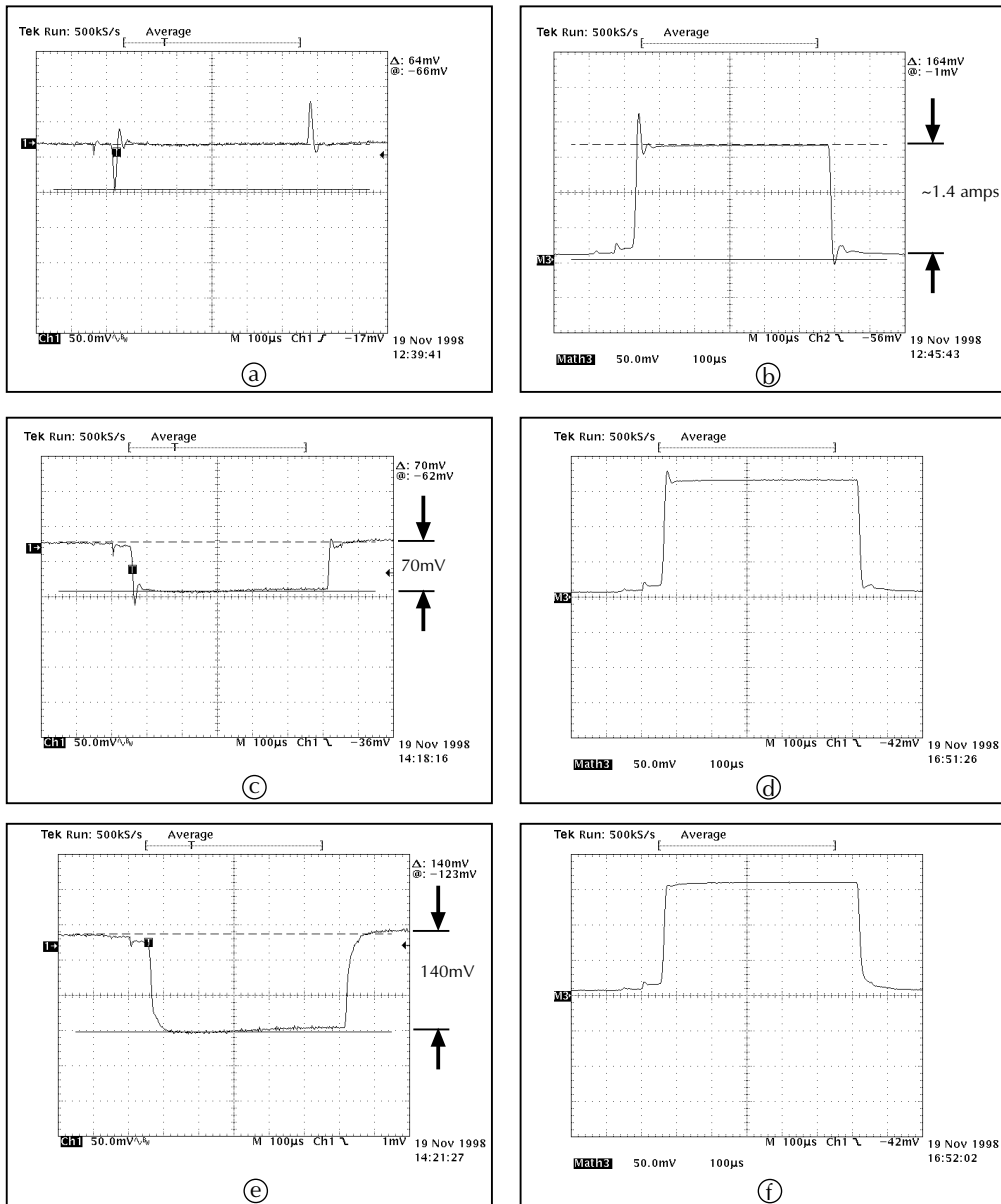

NOTE Figure E-5 contains the effect of the variable output impedance control of the Model 2306 on the current and voltage performance of a GSM handset.

Two methods are used to determine the impedance value of the cell or battery pack. The first method uses data from the battery manufacturer or another source and is simply entered into the Model 2306 from the front panel or over the GPIB bus. The second method involves a simple series of measurements as follows.

Figure E-6
Li ion voltage drop during the transmit portion of the pulse

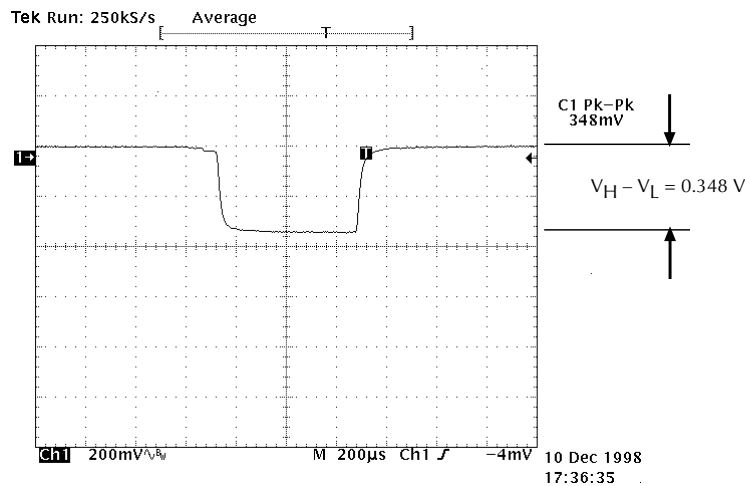

NOTE Figure E-6 shows the voltage drop during the transmit portion of the pulse of a GSM phone with the supplied Li ion.

Figure E-6 shows the transient voltage response at the battery terminals with the handset battery. Using the pulse current mode of the battery channel, the measured current during the transmit portion of the data frame is $I_H = 1.536\text{A}$ and the idle portion of the data frame is $I_L = 0.082\text{A}$. To estimate R_i from the measured voltage in Figure E-6, use:

$$R_i \cong \frac{V_H - V_L}{I_H - I_L} = \frac{0.348\text{V}}{1.454\text{A}} = 0.239\Omega$$

Using this value for the output impedance setting in the battery channel the voltage drop across the output terminals, as shown in Figure E-7, is 0.360V. This value is in agreement, to within 3%, with the results obtained with the battery included with the handset.

Figure E-7

Model 2306 voltage drop during the transmit portion of the pulse

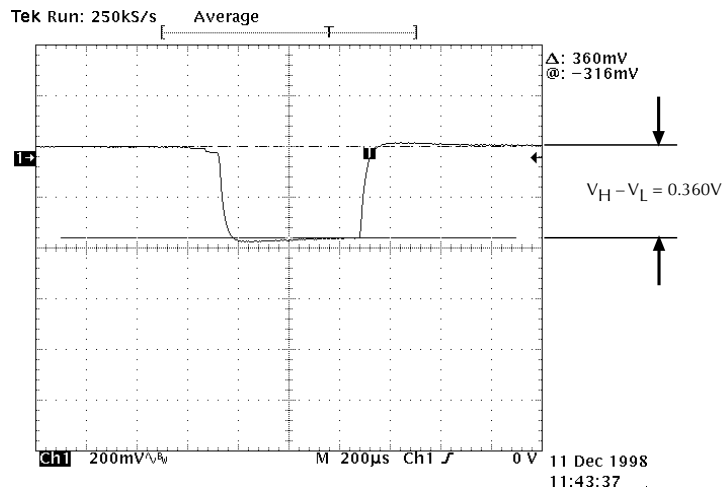

NOTE Figure E-7 contains the voltage drop during the transmit portion of the pulse of a GSM phone with the Model 2306 battery channel, output impedance set to 0.24Ω .

F Model 2302 Specifics

This appendix provides information specific to the Model 2302 and 2302-PJ. Although the Model 2302 and 2302-PJ are operated the same way as the Model 2306 and 2306-PJ, there are minor differences. This appendix documents these variances.

General information

NOTE Since the Model 2302 and 2302-PJ are single channel battery simulators, functions contained in this manual related to the second channel (i.e., the charger channel) are not available for the Model 2302 and 2302-PJ. With this in mind, for the Model 2302 and 2302-PJ, only battery channel features contained in this manual apply.

Specifications

Full power supply specifications can be found in Appendix A of this manual.

Power supply overview

The Model 2302 and 2302-PJ power supplies (single channel battery simulator — Figure F-1) simulate a battery. The features match the battery channel features (Channel 1) documented in this manual (2306-901-01).

Operational differences

Front panel operation

Since the Model 2302 and 2302-PJ are single channel units, disregard any statements in the manual such as “Toggle active channel using the ◀ or ▶ keys.” Also, the #1 or #2 indicating the active channel is not displayed—the active channel is always the battery channel.

SCPI operation

If a channel 2 bus command is issued, an “Undefined header” error (-113) will result.

*IDN? will reflect the Model 2302 and 2302-PJ instead of the Model 2306 and 2306-PJ.

When using the DISP:CHAN command, only send a “1” as a parameter. Other values will result in a parameter data out of range error (-222).

The BOTHOUTON and BOTHOUTOFF commands do not work with the Model 2302 or 2302-PJ.

Calibration

When performing a front panel calibration on the Model 2302 and 2302-PJ (Section 13), perform steps 1, 2, and 4, i.e., skip step 3: Perform Channel #2 (charger channel) calibration steps. Also, the Model 2302 and 2302-PJ Cal Code is: KI002302

When performing a remote calibration on the Model 2302 and 2302-PJ (Section 13), calibrate CHAN1 only. Make modifications as required to Program D-1 Model 2306 calibration program (Appendix D) to account for one channel.

Figure F-1
 Model 2302 and 2302-PJ single channel battery simulator

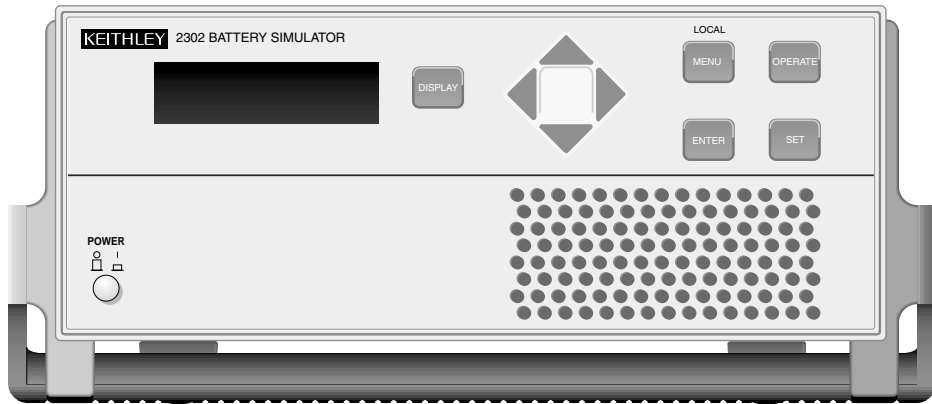

A) Front Panel

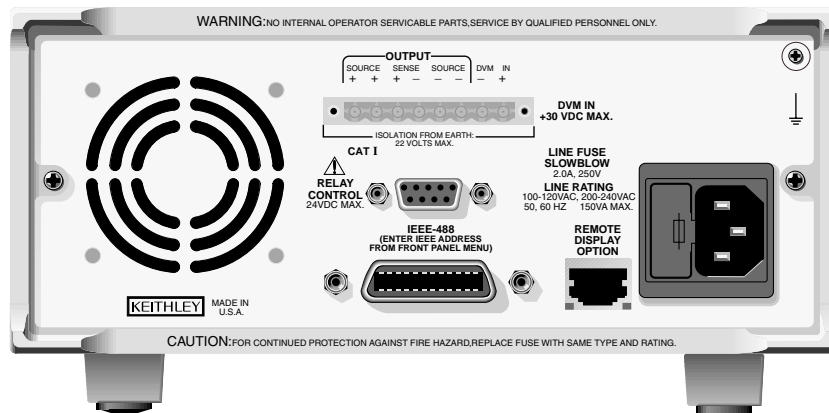

B) Rear Panel

Index

:BOTHOUTOFF 2-12
:BOTHOUTON 2-12

A

Actual V and I 1-9
Actual V and I display mode 2-14
Ambient temperature 12-2
 Calibration 13-2
AMP 4-12
Analog board parts list 15-7
Analog board removal 14-4
Angle Brackets 6-10
ASCII format 10-5
Assembly drawings 14-3
AUTO TIME 1-13, 1-14, 4-6
Average readings 1-13, 2-15
AVERAGE TIME 1-13

B

Basic power supply operation 2-1
Battery schematic E-2
BOTHOUTOFF 2-14
BOTHOUTON 2-14

C

CALIBRATE UNIT 1-13
Calibration
 Acquiring date and count by remote 13-19
 Ambient temperature 13-2
 Changing the code 13-17
 Changing the code by remote 13-18
 Changing the code from the front panel 13-17
 Connections
 Resistor 13-3
 Considerations 13-2
 Cycle 13-3
 Enter dates and save 13-11
 Environmental conditions 13-2
 Front panel 13-4
 Introduction 13-2
 Jumper connections to reset code 13-19
 Line power 13-2
 Prepare the Model 2306 13-4, 13-12
 Program date 13-15
 Recommended equipment 13-3
 Remote 13-11

Remote display 13-11
Remote procedure 13-11
Remote summary 13-16
Resetting the code 13-18
Resistor considerations 13-3
Save constants and lock out 13-15
Temperature and relative humidity 13-2
Viewing date and count 13-19
Viewing date and count from the front panel 13-19
Warm-up period 13-2

Calibration steps

 Perform Channel #1 (Battery Channel) 13-5, 13-12
 Perform Channel #2 (Charger Channel) 13-8, 13-14

Case cover removal 14-3

Case sensitivity 6-11

Clearing registers and queues 7-4

Command execution rules 6-13

Command notes

 IEEE-488.2 common commands and queries 8-3

 Long integration measurements 4-14

 Measure V and I, and DVM input 2-17

 Outputting voltage and current 2-13

 Pulse current measurements 3-16

 SCPI commands—data format 10-5

 SCPI commands—display 10-2

 SCPI commands—system 10-8

 Signal oriented measurement commands and queries 9-3

Command path rules 6-13

Command words 6-9

Common and SCPI commands

 Condition registers 7-17

 Event enable registers 7-18

 Event registers 7-17

Common commands

 *IDN? — identification query 8-3

 *OPC — operation complete 8-3

 *OPC and *OPC? commands 8-4

 *OPC? — operation complete query 8-3

 *RCL — recall 8-4

 *RST — reset 8-5

 *SAV — save 8-4

 *TRG1 — trigger 8-5

 *TRG2 — trigger 8-5

 *TST? — self-test query 8-5

 *WAI — wait-to-continue 8-5

Common commands and queries 8-2

Condition registers 7-17

Connections

5A current calibration 13-7

5mA range calibration 13-8

GPIB bus 6-2

Relay control 5-4

Resistor 12-3

Voltage calibration 13-5

Contact information 1-2

Controlling relays 5-4

CURR LIM MODE 1-13

Current limit modes 2-6

CURRENT RANGE 1-13

Current range 2-15, 4-6

Current ranges 2-6

Current Readback Range 1-5

D

Daisy chaining 6-3

Daisy-chain 6-2

DCL (device clear) 6-7

Default settings 1-10

Determining correct trigger level

(long integration) 4-10

Device clear 6-7

Digital board parts list 15-3

Digital board removal 14-4

Digital voltmeter 1-5

Disassembly procedures 14-3

Display board parts list 15-14

Display command summary 11-3

Display modes 1-9

Display samples 1-10

DISPlay subsystem 10-2

Drawings 14-3

DVM 1-5

Input 1-9

input display mode 2-17

measurements 2-21

E

Editing

Restrictions 2-9

Shortcuts 2-9

Effect of the variable output impedance

control E-5

Electronic resistance of NiCd, NiMH, and

Li ion battery packs E-4

Error and status messages 6-8

Error queue 7-20

Event enable registers 7-18

Event registers 7-17

External source relay control 5-3

F

Factory service 15-2

FAST, SEARCh and DETect command

reference

Long Integration 4-14

Pulse Current 3-17

FORMat 10-4

FORMat command summary 11-3

FORMat subsystem 10-4

Four-wire sense connections for battery and

charger channels 2-3

Front panel

aspects of GPIB operation 6-8

calibration 13-4

disassembly 14-4

Fuse drawer location 1-8

G

General

bus commands 6-6

information 1-2

notes 4-10

GET (group execute trigger) 6-7

Getting around the MENU 1-15

Go to local 6-7

GPIB

ADDRESS 1-13

bus connections 6-2

Operation 6-1

Group execute trigger 6-7

GSM cellular handsets E-2

GTL (go to local) 6-7

H

Handling and cleaning 14-2

HIGH TIME 1-13

hysteresis 3-8

I

Identification query 8-3

IEEE 754 formats 10-5

IEEE-488 connector 6-2

IEEE-488.2 common commands and

queries 8-2

IEEE-754 double precision data format 10-6

IEEE-754 single precision data format 10-5

IFC (interface clear) 6-6
Independent voltage measurements (DVM) 2-17
Inspection 1-3
Instrument re-assembly 14-5
Integration time 1-14, 4-6
Interface clear 6-6
internal impedance E-2
Internal source relay control 5-3
Introduction
 Calibration 13-2
 Disassembly 14-2
 GPIB Operation 6-2
 Replaceable parts 15-2
 Verification 12-2

L

LI, NiMH, and NiCd handset battery packs E-3
Line power
 Calibration 13-2
 Verification 12-3
LLO (local lockout) 6-7
LOCAL key 6-8
Local lockout 6-7
Local sense connections 2-4
LONG INTEGRAT 1-14
Long integration 1-9, 4-2
 display mode 4-9
 measurement procedure 4-9
 Measurements 4-1
 Integration time 4-3
 Programming example 4-18
 Trigger edge 4-3
 readings 6-5
 search, and reading time comparison 4-5
Long-form and short-form versions 6-11
LOW TIME 1-13

M

Main MENU structure 1-13
MAV (Message Available Bit) 6-5
Measurement configuration 2-15, 2-18, 4-6
Measurement event status 7-14, 7-15
Mechanical parts list 15-15
Menu 1-12
Message Available Bit 6-5
Message exchange protocol 6-14
Model 2306 Dual Channel Battery/Charger
 Simulator 1-4, F-3
Multiple command messages 6-12
Multiple response messages 6-14

N

NPLC RATE 1-13
NPLC rate 2-15

O

Operation event status 7-12, 7-13
Optional Command Words 1-16
Options and accessories 1-3
Ordering information 15-2
Output bandwidth 1-13
OUTPut command summary 11-4
Output impedance 1-13, 2-11
 changing 2-11
Output queue 7-20
OUTPUT RELAYS 1-13
Outputting and reading back V and I 2-20
Outputting voltage and current 2-5
Overview
 Common commands 8-2
 Long Integration Measurements 4-2
 Pulse Current Measurements 3-2
 Relay control 5-2
 Signal oriented measurement commands 9-2
 Status structure 7-2

P

Parameters 6-9
Parts lists and component layouts 15-2
PC boards handling 14-2
PCURrent FAST, SEARch, and DETect command reference 3-19
Phone numbers 1-2
POWER ON SETUP 1-13
Power supply overview 1-4, F-2
Power Up
 Connection
 Line Power 1-7
 Fuse replacement 1-8
 Sequence 1-7
Primary address 6-4
Program message terminator (PMT) 6-13
Programming
 and reading registers 7-5
 enable registers 7-5
Programming examples 2-20
 Program and read measurement event register 7-19
Pulse current digitization 3-30, 3-31
Pulse current measurements 3-29

- Read error queue 7-21
- Read status byte 7-9
- Programming syntax 6-9
- Pulse Current Measurements 3-1, 3-2
 - Configuration 3-6
 - digitization 3-21
 - Integration times 3-5
 - Menu items 1-13
 - Mode 1-9
 - Programming examples 3-28
 - Pulse sequences 3-25, 3-26
 - readings 6-5
 - step method 3-22
 - TLEV Steps 3-22
 - Trigger level settings 3-24
- Pulse timeout 1-13, 1-14, 3-7, 3-15, 3-17, 4-4, 4-7, 11-12

Q

- Query commands 1-16, 6-10
- Questionable event status 7-16
- Queues 7-2, 7-19

R

- READ
 - ARRay? 3-15
- READ? 3-15, 4-13, 6-4, 6-5, 9-3
- Reading back V and I 2-14
- Reading registers 7-5
- Re-assembly 14-5
- RECALL SETUP 1-13
- Register bit descriptions 7-10
- Relay
 - connector (9-pin D-sub) 5-4
 - control 5-1
 - Pinouts 5-4
- Remote
 - display option 1-6
 - enable 6-6
 - indicator and LOCAL key 6-8
 - Sense 2-3
- remote display 1-6
- Remote display option 1-6
- Removal
 - Analog board 14-4
 - Case cover 14-3
 - Digital board 14-4
 - Mechanical components 14-5
- REN (remote enable) 6-6
- Resistor considerations 12-4
- Response message terminator (RMT) 6-14
- REVISION NUMBER 1-13

S

- Safety symbols and terms 1-2
- SAVE SETUP 1-13
- SCPI command
 - display 10-2
 - Error queue 7-21
 - General notes 11-2
 - Output relay control 5-5
 - Outputting voltage and current 2-12
 - Subsystems reference tables 11-2
- SCPI programming 1-16, 3-13, 4-12
 - DVM 2-18
 - Measure V and I, and DVM input 2-16
 - Outputting voltage and current 2-12
- SDC (selective device clear) 6-7
- Selective device clear 6-7
- Sending a response message 6-14
- SENSe command summary 11-5
- SERIAL NUMBER 1-13
- Serial polling 6-7, 7-8
- Serial polling and SRQ 7-8
- Service request enable register 7-7
- Setting the GPIB timeout for Responses 6-4
- Setups — Save, Power-on, and Recall 1-12
- Short-form rules 6-11
- Signal oriented measurement command
 - summary 9-2, 11-17
- Signal Oriented Measurement commands 9-2
- Simplified power supply diagram 1-5
- Simulated GSM phone current profile E-4
- Simulating battery impedance E-2
- Single command messages 6-12
- Sink operation 2-18
- Solder repairs 14-2
- SOURce command summary 11-14
- SPE, SPD (serial polling) 6-7, 7-8
- Specifications 1-2, F-2
- Specifying the timeout length for the pulse 4-4
- Standard event status 7-10, 7-11
- Static sensitive devices 14-2
- Status
 - byte register 7-7
 - command summary 11-15
 - model structure 7-3
 - register sets 7-2, 7-10
 - structure 7-1
- Status byte and
 - service request (SRQ) 7-6
 - service request commands 7-9
- SRQ 7-2

status register
16-bit 7-5
Step measurements
Integration time 3-28
Trigger level range 3-28
SYSTEM command summary 11-17

T

TDMA and GSM cellular handsets E-2
Temperature coefficient 12-4, 13-4
Test connections 2-2
TRG LEV mA RANGE 1-14
TRG LEVEL mA 1-14
TRIG LEV RANGE 1-13, 1-14
TRIGGER DELAY 1-13
Trigger delay 3-4
Trigger delay for High Pulse current
measurement 3-4
TRIGGER EDGE 1-14
Trigger edge, trigger level, and trigger level
range 4-7
TRIGGER LEVEL 1-14
Trigger level 3-3, 4-4
Trigger level range (pulse current
trigger level) 3-3
Triggering the start of the measurement 4-3

U

Using common and SCPI commands in the
same message 6-13
Using FAST, SEARCH, and DETect 3-17, 4-14
Using TimeOUT 4-5

V

Variable output impedance control E-2
Verification
Ambient temperature 12-2
Environmental conditions 12-2
Line power 12-3
Recommended test equipment 12-3
Test requirements 12-2
Warm-up period 12-2
VFD BRIGHTNESS 1-6, 1-13
VOLT PROTECT 1-13
Voltage drop during the transmit portion of
the pulse E-6, E-7
Voltage drop equation 2-11

W

Warranty information 1-2
Waveform filtering 4-2
Waveform with low pulse time
(less than 200ms) 4-3



Service Form

Model No. _____ Serial No. _____ Date _____

Name and Telephone No. _____

Company _____

List all control settings, describe problem and check boxes that apply to problem. _____

Intermittent Analog output follows display Particular range or function bad; specify _____

IEEE failure Obvious problem on power-up Batteries and fuses are OK

Front panel operational All ranges or functions are bad Checked all cables

Display or output (check one)

Drifts Unable to zero Unstable

Overload Will not read applied input

Calibration only Certificate of calibration required Data required

(attach any additional sheets as necessary)

Show a block diagram of your measurement including all instruments connected (whether power is turned on or not). Also, describe signal source.

Where is the measurement being performed? (factory, controlled laboratory, out-of-doors, etc.) _____

What power line voltage is used? _____ Ambient temperature? _____ °F

Relative humidity? _____ Other? _____

Any additional information. (If special modifications have been made by the user, please describe.)

Be sure to include your name and phone number on this service form.

Specifications are subject to change without notice.

All Keithley trademarks and trade names are the property of Keithley Instruments, Inc. All other trademarks and trade names are the property of their respective companies.



Keithley Instruments, Inc.

BELGIUM: Keithley Instruments B.V.
CHINA: Keithley Instruments China
FRANCE: Keithley Instruments Sarl
GERMANY: Keithley Instruments GmbH
GREAT BRITAIN: Keithley Instruments Ltd.
INDIA: Keithley Instruments GmbH
ITALY: Keithley Instruments s.r.l.
KOREA: Keithley Instruments Korea
NETHERLANDS: Keithley Instruments B.V.
SWITZERLAND: Keithley Instruments SA
TAIWAN: Keithley Instruments Taiwan

28775 Aurora Road • Cleveland, Ohio 44139 • 440-248-0400 • Fax: 440-248-6168

1-888-KEITHLEY (534-8453) www.keithley.com

Bergensesteenweg 709 • B-1600 Sint-Pieters-Leeuw • 02/363 00 40 • Fax: 02/363 00 64
Yuan Chen Xin Building, Room 705 • 12 Yumin Road, Dewai, Madian • Beijing 100029 • 8610-6202-2886 • Fax: 8610-6202-2892
3, allée des Garays • 91127 Palaiseau Cédex • 01 64 53 20 20 • Fax: 01 60 11 77 26
Landsberger Strasse 65 • D-82110 Germering • 089/84 93 07-40 • Fax: 089/84 93 07-34
The Minster • 58 Portman Road • Reading, Berkshire RG30 1EA • 0118-9 57 56 66 • Fax: 0118-9 59 64 69
Flat 2B, WILLOCRISSA • 14, Rest House Crescent • Bangalore 560 001 • 91-80-509-1320/21 • Fax: 91-80-509-1322
Viale San Gimignano, 38 • 20146 Milano • 02-48 39 16 01 • Fax: 02-48 30 22 74
2FL., URI Building • 2-14 Yangjae-Dong • Seocho-Gu, Seoul 137-130 • 82-2-574-7778 • Fax: 82-2-574-7838
Postbus 559 • NL-4200 AN Gorinchem • 0183-635333 • Fax: 0183-630821
Kriesbachstrasse 4 • 8600 Dübendorf • 01-821 94 44 • Fax: 01-820 30 81
1FL., 85 Po Ai Street • Hsinchu, Taiwan, R.O.C. • 886-3-572-9077 • Fax: 886-3-572-9031